

SVX9000 Adjustable Frequency Drives

Contents

<i>Description</i>	<i>Page</i>
Product Family Overview	2
SVX9000 Open Drives	
Product Description	4
Features	4
Technical Data and Specifications	5
Catalog Number Selection	6
Product Selection	7
Options	13
Accessories	14
Dimensions	15
Spare Units and Replacement Parts	32
SVX9000 Enclosed Drives	
Product Description	38
Features	38
Standards and Certifications	38
Technical Data and Specifications	39
Catalog Number Selection	40
Product Selection	45
Dimensions	54
SVX9000 VFD Pump Panels	
Product Description	65
Features	65
Standards and Certifications	65
Technical Data and Specifications	66
Catalog Number Selection	67
Product Selection	71
Dimensions	77
Wiring Diagrams	83

Note: Supplement to Publication No. CA08102001E — Tab 40.



Product Family Overview

Overview

With the SVX9000 series sensorless vector control, Eaton's expanded Cutler-Hammer® drive offering now covers a complete line of PWM adjustable frequency (speed) drives in ratings from:

- 208V — 3/4 to 100 hp I_H ; 1 to 100 hp I_L
- 230V — 3/4 to 100 hp I_H ; 1 to 100 hp I_L
- 480V — 1 to 1900 hp I_H ; 1-1/2 to 2200 hp I_L
- 575V — 2 to 2000 hp I_H ; 3 to 2300 hp I_L

The 9000X Family of Drives includes HVX9000, SVX9000, SLX9000 and SPX9000 drives. 9000X Series drive ratings are rated for either high overload (I_H) or low overload (I_L). I_L indicates 110% overload capacity for 1 minute out of 10 minutes. I_H indicates 150% overload capacity for 1 minute out of 10 minutes.

A full range of enclosure types and options are available to meet a wide array of applications — from simple variable torque to more complex industrial applications such as conveyors, mixers and machine controls.

Application Description

Application Engineering

Proper selection and application of all drive system components is essential to assure that an adjustable frequency drive system will safely and reliably provide the performance required for any given application. The party responsible for the overall design and operation of the facility must make sure that qualified personnel are employed to select all components of the drive system, including appropriate safety devices. Eaton's Cutler-Hammer AF Drives Application Engineering Department is prepared to provide assistance to answer any questions about the technical capabilities of Cutler-Hammer drives.

Motor Selection

The basic requirement of motor selection is to match the torque vs. speed capability of the motor to the torque vs. speed requirement of the driven load.

Motor Torque vs. Speed Capability

As the speed of a motor is reduced below its 60 Hz base speed, motor cooling becomes less effective because of the reduced speed of the self-cooling fan. This limitation determines the maximum torque for continuous operation at any operating speed. The maximum intermittent operating torque is determined by the motor's torque vs. current characteristics and the output current capability of the adjustable frequency controller.

Multiple Motor Operation

A number of motors can be connected in parallel to a single controller. Since the frequency of the power supplied by the controller is the same for each motor, the motors will always operate at the same speed. Application Engineering assistance must be requested for all multiple motor applications to assure compliance with all controller design limitations.

Special Types of Motors

Standard NEMA Designs A and B three-phase motors are the only motors recommended for use in the majority of applications, but other types of motors are occasionally used. If the existing motor used in the application or the motor proposed for use with the drive system is a type other than NEMA Design A or B, Application Engineering assistance must be requested to make certain that the drive is properly applied.

Controller Selection

The basic requirement of controller selection is to match the output current, voltage and frequency capabilities of the controller with the requirements of the connected motor.

Output Current

The controller must be selected and applied such that the average operating motor current and horsepower do not exceed the continuous current and horsepower ratings of the controller. The intermittent operating current must not exceed the intermittent current rating of the controller.

Motor Protection

Cutler-Hammer adjustable frequency drives include electronic motor overload protection circuits that are designed to meet the requirements of NEC article 430-2 provided that only one motor is connected to the output of the controller.

Output Voltage and Frequency

When they are shipped, AF controllers are adjusted to provide a maximum output voltage and frequency equivalent to the input line voltage and frequency. The controllers can be adjusted to operate above line frequency, but a hazard of personal injury or equipment damage may exist when the motor is operated above base speed. Before adjusting the drive to operate above line frequency, make sure that the motor and the driven machinery can safely be operated at the resulting speed.

June 2006

Product Family Overview

Controller Features

Operator Control and Interface Requirements

Since there are many possible configurations and many ways of achieving a specific end result, it pays to consider the operator control and interface requirements carefully. A simplified and more economical drive package can often be achieved by selecting from standard product offerings rather than specifying a custom designed configuration.

Installation Compatibility

The successful application of an AC drive requires the assurance that the drive will be compatible with the environment in which it will be installed. In planning the installation, be sure to carefully consider the heat produced by the drive, the altitude and temperature limits and the need for clean cooling air. Other important considerations include acoustical noise, vibration, electromagnetic compatibility, power quality, controller input harmonic current and power distribution equipment requirements.

Auxiliary Equipment and Accessories

Adjustable drives are generally designed to have a motor directly connected to the controller output terminals with no other equipment connected in series or parallel. Motor starters, disconnect switches, surge absorbers, dv/dt suppression circuits, output chokes, output transformers and any other equipment under consideration for installation on the output of the controller should not be installed without first requesting Application Engineering assistance. Power factor correction capacitors must never, under any circumstances, be connected at the output of the controller. They would serve no useful purpose, and they may damage the controller.

Enclosure Definitions

■ **NEMA Type 1** — Enclosures are intended for indoor use primarily to provide a degree of protection against contact with enclosed equipment and provide a degree of protection against a limited amount of falling dirt in locations where unusual service conditions do not exist. Top or side openings in the NEMA Type 1 enclosure allow for the free exchange of inside and outside air while meeting the UL rod entry and rust resistance design tests.

- **NEMA Type 12** — Enclosures are intended for indoor use primarily to provide a degree of protection against circulating dust, falling dirt and dripping noncorrosive liquids. To meet UL drip, dust and rust resistance tests, NEMA Type 12 enclosures have no openings to allow for the exchange of inside and outside air.
- **Chassis IP00** — Similar to Protected Chassis IP20 except power terminals are protected by plastic shielding only. Primarily intended to be mounted inside a surrounding protective enclosure.
- **NEMA 3R** — Similar in design to NEMA Type 12 except with more stringent design and test requirements.

Motor Protection

DV/DT and Peak Motor Voltage Solutions

Today's AFD products offer significantly improved performance, but at the potential cost of motor insulation stress. The fast switching time of the IGBT devices used in newer AFDs can

cause a transmission line effect in the output power leads to the motor, leading to possibly damaging voltage levels. To meet this need, NEMA has introduced a motor in MG1, Part 31, which provides an insulation system designed to maintain normal motor life in AFD applications. For existing motors, a motor protection scheme is required for longer cable runs. Eaton offers three standard solutions for existing systems.

■ **Motor_x**

This patented Cutler-Hammer solution provides an energy recovery system which clamps the peak motor voltage to a safe level for standard motors. This option is used when the distance between a single motor and the drive is 600 feet or less.

■ **Output Line Reactor**

This option provides an output line reactor, reducing the DV/DT of the AFD output voltage and lessening the transmission line effect, to lower the peak voltage at the motor terminals.

Product Availability Codes

The product availability codes indicate the type of facility (warehouse, Mod Center or factory) that the product will ship from and, if it is not in stock, the number of working days needed to assemble the product from receipt of the order to shipment from the designated facility. Please note that this lead-time does not include any in-transit time from our facility to your facility.

Table 1. Product Availability Codes

Codes	Description
W	Warehouse stocked item. Shipped on customer request date. If item is backordered, please check Vista/VISTALINE or contact your Customer Support Center for product availability.
F1	Factory assemble-to-order. Shipped from factory within 1 working day after receipt of order on Vista.
FA	Factory assemble-to-order. Shipped from factory within 2 – 3 working days after receipt of order on Vista.
FB	Factory assemble-to-order. Shipped from factory within 4 – 10 working days after receipt of order on Vista.
FC	Factory assemble-to-order. Shipped from factory within 11 – 15 working days after receipt of order on Vista.
FD	Factory assemble-to-order. Shipped from factory within 16 – 20 working days after receipt of order on Vista.
FP	Factory assemble-to-order. Shipped from factory on negotiated promise date.
MA	Mod Center assemble-to-order. Shipped from Mod Center within 1 – 3 working days after receipt of order on Vista.
MB	Mod Center assemble-to-order. Shipped from Mod Center within 4 – 10 working days after receipt of order on Vista.
MP	Mod Center assemble-to-order. Shipped from Mod Center on negotiated promise date.

Product availability codes contained herein for a given product may be quantity sensitive and are subject to change without notice. For the most current information, refer to the Product Identification Inquiry (PIN) screen on Vista.

Open Drives

SVX9000 Open Drives



SVX9000 Open Drives

Product Description

Cutler-Hammer® SVX9000 Series Adjustable Frequency Drives from Eaton's electrical business are the next generation of drives specifically engineered for today's commercial and industrial applications. The power unit makes use of the most sophisticated semiconductor technology and a highly modular construction that can be flexibly adapted to the customer's needs.

The input and output configuration (I/O) is designed with modularity in mind. The I/O is comprised of option cards, each with its own input and output configuration. The control module is designed to accept a total of five of these cards. The cards contain not only normal analog and digital inputs but also fieldbus cards.

These drives continue the tradition of robust performance, and raise the bar on features and functionality, ensuring the best solution at the right price.

Features

- Robust design — proven 500,000 hours MTBF
- Integrated 3% line reactors standard on drives from FR4 through FR9
- EMI/RFI Filters H standard up to 200 hp I_H 480V, 100 hp I_H 230V
- Simplified operating menu allows for typical programming changes, while programming mode provides control of everything
- Quick Start Wizard built into the programming of the drive ensures a smooth start-up
- Keypad can display up to three monitored parameters simultaneously
- LOCAL/REMOTE operation from keypad
- Copy/Paste function allows transfer of parameter settings from one drive to the next
- Standard NEMA Type 12 keypad on all drives

- The SVX can be flexibly adapted to a variety of needs using our pre-installed "Seven in One" Precision application programs consisting of:
 - Basic
 - Standard
 - Local/Remote
 - Multi Step Speed Control
 - PID Control
 - Multi-Purpose Control
 - Pump and Fan Control with Auto Change
- Additional I/O and communication cards provide plug and play functionality
- I/O connections with simple quick connection terminals
- UL Listed
- Hand-Held Auxiliary 240 Power Supply allows programming/monitoring of control module without applying full power to the drive
- Control logic can be powered from an external auxiliary control panel, internal drive functions and fieldbus if necessary
- Brake Chopper standard from:
 - 1 – 30 hp/380 – 500V
 - 3/4 – 15 hp/208 – 230V
- NEMA Type 1 and NEMA Type 12 enclosures available, Frame Sizes FR4 – FR9
- Open Chassis FR10 and greater
- NEMA Type 1 and NEMA Type 12 available in FR10 Freestanding design; NEMA Type 1 available in FR11 Freestanding design
- Standard option board configuration includes an A9 I/O board and an A2 relay output board installed in slots A and B

June 2006

Open Drives

Technical Data and Specifications

Table 2. SVX9000 Specifications

Description	Specification
Input Ratings	
Input Voltage (V_{in})	+10% / -15%
Input Frequency (f_{in})	50/60 Hz (variation up to 45 – 66 Hz)
Connection to Power	Once per minute or less (typical operation)
High Withstand Rating	100 kAIC
Output Ratings	
Output Voltage	0 to V_{in}
Continuous Output Current	I_H rated 100% at 122°F (50°C), FR9 and below I_L rated 100% at 104°F (40°C), FR9 and below I_H/I_L 100% at 104°F (40°C), FR10 and above
Overload Current (I_H/I_L)	150% I_H , 110% I_L for 1 min.
Output Frequency	0 to 320 Hz
Frequency Resolution	.01 Hz
Initial Output Current (I_H)	250% for 2 seconds
Control Characteristics	
Control Method	Frequency Control (V/f) Open Loop: Sensorless Vector Control, Closed Loop: SPX9000 Drives Only
Switching Frequency Frame 4 – 6 Frame 7 – 12	Adjustable with Parameter 2.6.9 1 to 16 kHz; default 10 kHz 1 to 10 kHz; default 3.6 kHz
Frequency Reference	Analog Input: Resolution .1% (10-bit), accuracy \pm 1% V/Hz Panel Reference: Resolution .01 Hz
Field Weakening Point	30 to 320 Hz
Acceleration Time	0 to 3000 sec.
Deceleration Time	0 to 3000 sec.
Braking Torque	DC brake: 30% \times T_n (without brake option)
Ambient Conditions	
Ambient Operating Temperature	14°F (-10°C), no frost to 122°F (+50°C) I_H (FR4 – FR9) 14°F (-10°C), no frost to 104°F (+40°C) I_H (FR10 and up) 14°F (-10°C), no frost to 104°F (+40°C) I_L (all frames)
Storage Temperature	-40°F (-40°C) to 158°F (70°C)
Relative Humidity	0 to 95% RH, noncondensing, non-corrosive, no dripping water
Air Quality	Chemical vapors: IEC 721-3-3, unit in operation, class 3C2; Mechanical particles: IEC 721-3-3, unit in operation, class 3S2
Altitude	100% load capacity (no derating) up to 3280 ft. (1000m); 1% derating for each 328 ft. (100m) above 3280 ft. (1000m); max. 9842 ft. (3000m)
Vibration	EN 50178, EN 60068-2-6; 5 to 50 Hz, Displacement amplitude 1 mm (peak) at 3 to 15.8 Hz, Max. acceleration amplitude 1G at 15.8 to 150 Hz
Shock	EN 50178, EN 60068-2-27 UPS Drop test (for applicable UPS weights) Storage and ship- ping: max. 15G, 11 ms (in package)
Enclosure Class	NEMA 1/IP21 or NEMA 12/IP54, Open Chassis/IP20

Description	Specification
Standards	
Product	IEC 61800-2
Safety	UL 508C
EMC (at default settings)	Immunity: Fulfills all EMC immunity require- ments; Emissions: EN 61800-3, LEVEL H
Control Connections	
Analog Input Voltage	0 to 10V, R = 200 k Ω (-10 to 10V joystick con- trol) Resolution .1%; accuracy \pm 1%
Analog Input Current	0(4) to 20 mA; R_i - 250 Ω differential
Digital Inputs (6)	Positive or negative logic; 18 to 30V DC
Auxiliary Voltage	+24V \pm 15%, max. 250 mA
Output Reference Volt- age	+10V +3%, max. load 10 mA
Analog Output	0(4) to 20 mA; R_L max. 500 Ω ; Resolution 10 bit; Accuracy \pm 2%
Digital Outputs	Open collector output, 50 mA/48V
Relay Outputs	2 programmable Form C relay outputs Switching capacity: 24V DC / 8A, 250V AC / 8A, 125V DC / 0.4A

Protections

Overcurrent Protection	Trip limit 4.0 \times I_H instantaneously
Overvoltage Protection	Yes
Undervoltage Protection	Yes
Earth Fault Protection	In case of earth fault in motor or motor cable, only the frequency converter is protected
Input Phase Supervision	Trips if any of the input phases are missing
Motor Phase Supervision	Trips if any of the output phases are missing
Overtemperature Protection	Yes
Motor Overload Protection	Yes
Motor Stall Protection	Yes
Motor Underload Protection	Yes
Short Circuit Protection	Yes (+24V and +10V Reference Voltages)

Table 3. Standard I/O Specifications

Description	Specification
6 – Digital Input Programmable	24V: "0" \leq 10V, "1" \geq 18V, R_i > 5 k Ω
2 – Analog Input Configurable w/Jumpers	Voltage: 0 – \pm 10V, R_i > 200 k Ω Current: 0 (4) – 20 mA, R_i = 250 k Ω
2 – Digital Output Programmable	Form C Relays 250V AC 2 Amp or 30V DC 2 Amp resistive
1 – Digital Output Programmable	Open collector 48V DC 50 mA
1 – Analog Output Programmable Configurable w/Jumper	0 – 20 mA, R_L < 500 ohms, resolution 10 Bits/0.1%

Open Drives

Catalog Number Selection

Table 4. Adjustable Frequency Drive Catalog Numbering System

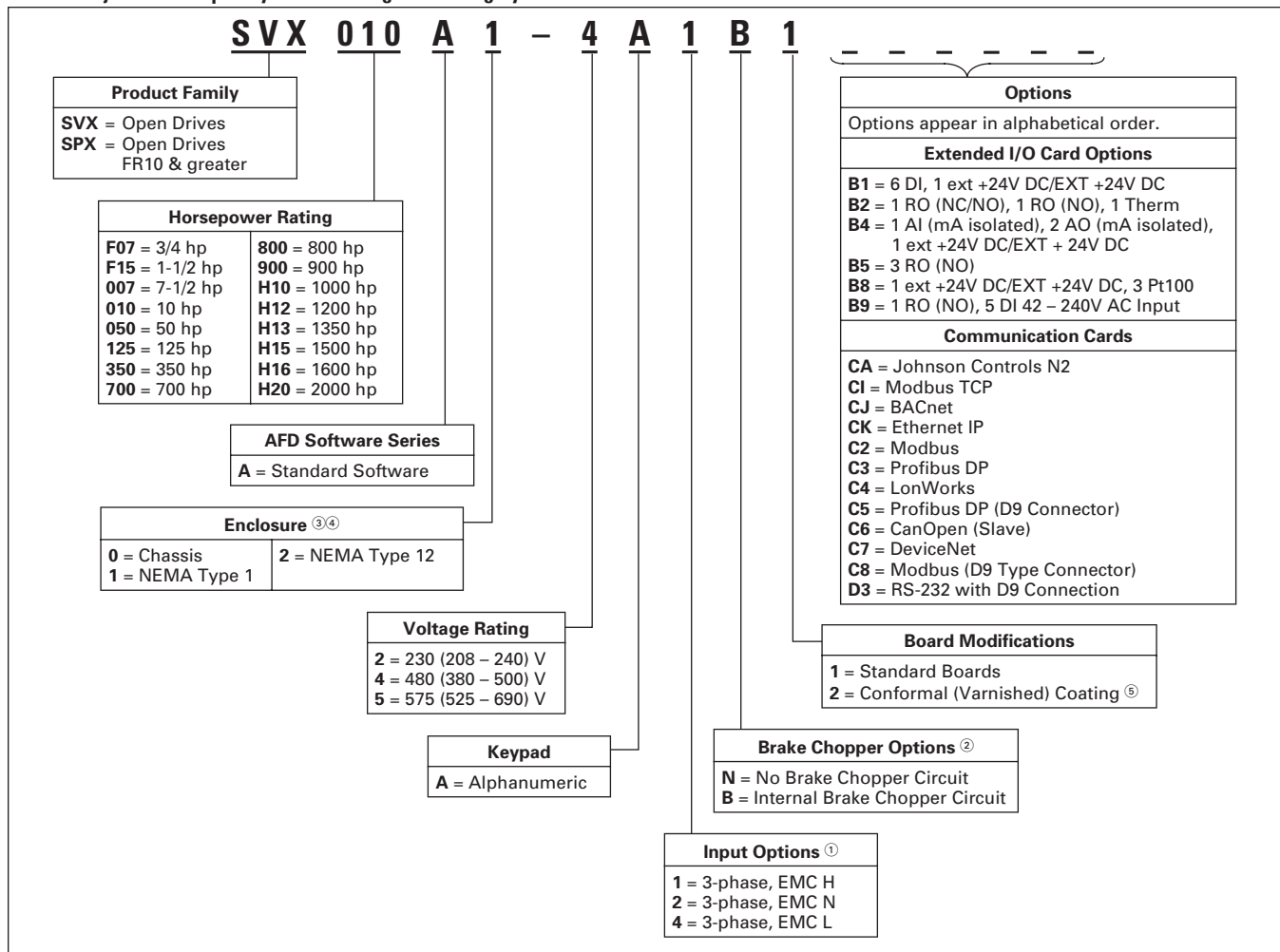

① All 230V Drives and 480V Drives up to 200 hp (I_H) are only available with Input Option 1 (EMC Level H). 480V Drives 250 hp (I_H) or larger are available with Input Option 2 (EMC Level N). 480V Drives are available with Input Option 4 (EMC Level L). 575V Drives 200 hp (I_H) or larger are only available with Input Option 2. 575V Drives up to 150 hp (I_H) are only available with Input Option 4 (EMC Level L).

② 480V Drives up to 30 hp (I_H) are only available with Brake Chopper Option B. 480V Drives 40 hp (I_H) or larger come standard with Brake Chopper Option N. 230V Drives up to 15 hp (I_H) are only available with Brake Chopper Option B. 230V Drives 20 hp or larger come standard with Brake Chopper Option N. All 575V Drives come standard without Brake Chopper Option (N). **Note:** N = No Brake Chopper.

③ 480V Drives 250 hp (I_H) and larger are available with enclosure style 0 (Chassis); 690V Drives 200 hp (I_H) and larger are available with enclosure style 0 (Chassis).

④ 480V and 690V FR10 Freestanding Drives are available with enclosure style 1 (NEMA Type 1) and enclosure style 2 (NEMA Type 12). FR11 Freestanding Drives only available with enclosure style 1 (NEMA Type 1).

⑤ Factory promise delivery. Consult Sales Office for availability.

Product Selection

230V SVX9000 Drives

Table 5. 208 – 240V, NEMA Type 1 Drive

Frame Size	Delivery Code	hp (I _H)	Current (I _H)	hp (I _L)	Current (I _L)	Catalog Number	Price U.S. \$
FR4	W	3/4	3.7	1	4.8	SVXF07A1-2A1B1	
		1	4.8	1-1/2	6.6	SVX001A1-2A1B1	
		1-1/2	6.6	2	7.8	SVXF15A1-2A1B1	
		2	7.8	3	11	SVX002A1-2A1B1	
		3	11	—	12.5	SVX003A1-2A1B1	
FR5	W	—	12.5	5	17.5	SVX004A1-2A1B1	
		5	17.5	7-1/2	25	SVX005A1-2A1B1	
		7-1/2	25	10	31	SVX007A1-2A1B1	
FR6	W	10	31	15	48	SVX010A1-2A1B1	
		15	48	20	61	SVX015A1-2A1B1	
FR7	W	20	61	25	75	SVX020A1-2A1N1	
		25	75	30	88	SVX025A1-2A1N1	
		30	88	40	114	SVX030A1-2A1N1	
FR8	W	40	114	50	140	SVX040A1-2A1N1	
		50	140	60	170	SVX050A1-2A1N1	
		60	170	75	205	SVX060A1-2A1N1	
FR9	W	75	205	100	261	SVX075A1-2A1N1	
		100	261	—	—	SVX100A1-2A1N1	

Table 6. 208 – 240V, NEMA Type 12 Drive

Frame Size	Delivery Code	hp (I _H)	Current (I _H)	hp (I _L)	Current (I _L)	Catalog Number	Price U.S. \$
FR4	F1	3/4	3.7	1	4.8	SVXF07A2-2A1B1	
		1	4.8	1-1/2	6.6	SVX001A2-2A1B1	
		1-1/2	6.6	2	7.8	SVXF15A2-2A1B1	
		2	7.8	3	11	SVX002A2-2A1B1	
		3	11	—	12.5	SVX003A2-2A1B1	
FR5	F1	—	12.5	5	17.5	SVX004A2-2A1B1	
		5	17.5	7-1/2	25	SVX005A2-2A1B1	
		7-1/2	25	10	31	SVX007A2-2A1B1	
FR6	F1	10	31	15	48	SVX010A2-2A1B1	
		15	48	20	61	SVX015A2-2A1B1	
FR7	W	20	61	25	75	SVX020A2-2A1N1	
		25	75	30	88	SVX025A2-2A1N1	
		30	88	40	114	SVX030A2-2A1N1	
FR8	FP	40	114	50	140	SVX040A2-2A1N1	
		50	140	60	170	SVX050A2-2A1N1	
		60	170	75	205	SVX060A2-2A1N1	
FR9	FP	75	205	100	261	SVX075A2-2A1N1	
		100	261	—	—	SVX100A2-2A1N1	

480V SVX9000 Drives

Table 7. 380 – 500V, NEMA Type 1 Drive

Frame Size	Delivery Code	hp (I _H)	Current (I _H)	hp (I _L)	Current (I _L)	Catalog Number	Price U.S. \$
FR4	W	1	2.2	1-1/2	3.3	SVX001A1-4A1B1	
		1-1/2	3.3	2	4.3	SVXF15A1-4A1B1	
		2	4.3	3	5.6	SVX002A1-4A1B1	
		3	5.6	5	7.6	SVX003A1-4A1B1	
		5	7.6	—	9	SVX005A1-4A1B1	
		—	9	7-1/2	12	SVX006A1-4A1B1	
FR5	W	7-1/2	12	10	16	SVX007A1-4A1B1	
		10	16	15	23	SVX010A1-4A1B1	
		15	23	20	31	SVX015A1-4A1B1	
FR6	W	20	31	25	38	SVX020A1-4A1B1	
		25	38	30	46	SVX025A1-4A1B1	
		30	46	40	61	SVX030A1-4A1B1	
FR7	W	40	61	50	72	SVX040A1-4A1N1	
		50	72	60	87	SVX050A1-4A1N1	
		60	87	75	105	SVX060A1-4A1N1	
FR8	W	75	105	100	140	SVX075A1-4A1N1	
		100	140	125	170	SVX100A1-4A1N1	
		125	170	150	205	SVX125A1-4A1N1	
FR9	W	150	205	200	261	SVX150A1-4A1N1	
		200	245	250	300	SVX200A1-4A1N1	

Discount Symbol..... SS-2

Open Drives

Table 8. 380 – 500V, NEMA Type 1 Freestanding Drive

Frame Size	Delivery Code	hp (I _H)	Current (I _H)	hp (I _L)	Current (I _L)	Catalog Number	Price U.S. \$
FR10	W	250	330	300	385	SPX250A1-4A4N1	
	FP	300	385	350	460	SPX300A1-4A4N1	
	W	350	460	400	520	SPX350A1-4A4N1	
FR11	FP	400	520	500	590	SPX400A1-4A4N1	
	FP	500	590	550	650	SPX500A1-4A4N1	
	FP	550	650	600	730	SPX550A1-4A4N1	

Note: Integrated fuses as standard. Limited option selection available; 115V Transformer (KB), Light Kit (L1), HOA (K4), Speed Potentiometer w/HOA (K2), Disconnect Switch (P2). See Enclosed 480V option selection.

Table 9. 380 – 500V, NEMA Type 12 Drive

Frame Size	Delivery Code	hp (I _H)	Current (I _H)	hp (I _L)	Current (I _L)	Catalog Number	Price U.S. \$
FR4	F1	1	2.2	1-1/2	3.3	SVX001A2-4A1B1	
		1-1/2	3.3	2	4.3	SVXF15A2-4A1B1	
		2	4.3	3	5.6	SVX002A2-4A1B1	
		3	5.6	5	7.6	SVX003A2-4A1B1	
		5	7.6	—	9	SVX005A2-4A1B1	
		—	9	7-1/2	12	SVX006A2-4A1B1	
FR5	F1	7-1/2	12	10	16	SVX007A2-4A1B1	
		10	16	15	23	SVX010A2-4A1B1	
		15	23	20	31	SVX015A2-4A1B1	
FR6	F1	20	31	25	38	SVX020A2-4A1B1	
		25	38	30	46	SVX025A2-4A1B1	
		30	46	40	61	SVX030A2-4A1B1	
FR7	W	40	61	50	72	SVX040A2-4A1N1	
		50	72	60	87	SVX050A2-4A1N1	
		60	87	75	105	SVX060A2-4A1N1	
FR8	W	75	105	100	140	SVX075A2-4A1N1	
		100	140	125	170	SVX100A2-4A1N1	
		125	170	150	205	SVX125A2-4A1N1	
FR9	W	150	205	200	261	SVX150A2-4A1N1	
		200	245	250	300	SVX200A2-4A1N1	

Table 10. 380 – 500V, NEMA Type 12 Freestanding Drive

Frame Size	Delivery Code	hp (I _H)	Current (I _H)	hp (I _L)	Current (I _L)	Catalog Number	Price U.S. \$
FR10	FP	250	330	300	385	SPX250A2-4A4N1	
	FP	300	385	350	460	SPX300A2-4A4N1	
	FP	350	460	400	520	SPX350A2-4A4N1	

Note: Integrated fuses as standard. Limited option selection available; 115V Transformer (KB), Light Kit (L1), HOA (K4), Speed Potentiometer w/HOA (K2), Disconnect Switch (P2). See Enclosed 480V option selection.

Table 11. 480V 380 – 500, Open Chassis Drive

Frame Size	Delivery Code	hp (I _H)	Current (I _H)	hp (I _L)	Current (I _L)	Catalog Number	Price U.S. \$
FR10 ^①	W	250	330	300	385	SPX250A0-4A2N1	
		300	385	350	460	SPX300A0-4A2N1	
		350	460	400	520	SPX350A0-4A2N1	
FR11	W	400	520	500	590	SPX400A0-4A2N1	
		500	590	—	650	SPX500A0-4A2N1	
		—	650	600	730	SPX550A0-4A2N1	
FR12	FP W FP	600	730	—	820	SPX600A0-4A2N1	
		—	820	700	920	SPX650A0-4A2N1	
		700	920	800	1030	SPX700A0-4A2N1	
FR13	FP	800	1030	900	1150	SPX800A0-4A2N1	
		900	1150	1000	1300	SPX900A0-4A2N1	
		1000	1300	1200	1450	SPXH10A0-4A2N1	
FR14	FP	1200	1600	1500	1770	SPXH12A0-4A2N1	
		1600	1940	1800	2150	SPXH16A0-4A2N1	
		1900	2300	2200	2700	SPXH19A0-4A2N1	

^① FR10 – FR14 includes 3% line reactor, but it is not integral to chassis.

Open Drives

575V SVX9000 Drives

Table 12. 525 – 690V, NEMA Type 1 Drive

Frame Size	Delivery Code	hp (I _H)	Current (I _H)	hp (I _L)	Current (I _L)	Catalog Number	Price U.S. \$
FR6	W	2	3.33	3	4.5	SVX002A1-5A4N1	
		3	4.5	—	5.5	SVX003A1-5A4N1	
		—	5.5	5	7.5	SVX004A1-5A4N1	
		5	7.5	7-1/2	10	SVX005A1-5A4N1	
		7-1/2	10	10	13.5	SVX007A1-5A4N1	
		10	13.5	15	18	SVX010A1-5A4N1	
		15	18	20	22	SVX015A1-5A4N1	
		20	22	25	27	SVX020A1-5A4N1	
		25	27	30	34	SVX025A1-5A4N1	
		FR7	W	30	34	40	
40	41			50	52	SVX040A1-5A4N1	
FR8	W	50	52	60	62	SVX050A1-5A4N1	
		60	62	75	80	SVX060A1-5A4N1	
		75	80	100	100	SVX075A1-5A4N1	
FR9	W	100	100	125	125	SVX100A1-5A4N1	
		125	125	150	144	SVX125A1-5A4N1	
		150	144	—	170	SVX150A1-5A4N1	
		—	170	200	208	SVX175A1-5A4N1	

Table 13. 525 – 690V, NEMA Type 1 Freestanding Drive

Frame Size	Delivery Code	hp (I _H)	Current (I _H)	hp (I _L)	Current (I _L)	Catalog Number	Price U.S. \$
FR10	FP	200	208	250	261	SPX200A1-5A4N1	
		250	261	300	325	SPX250A1-5A4N1	
		300	325	400	385	SPX300A1-5A4N1	
FR11	FP	400	385	450	460	SPX400A1-5A4N1	
		450	460	500	502	SPX450A1-5A4N1	
		500	502	550	590	SPX500A1-5A4N1	

Note: Integrated fuses as standard. Limited option selection available; 115V Transformer (KB), Light Kit (L1), HOA (K4), Speed Potentiometer w/HOA (K2), Disconnect Switch (P2). See Enclosed 480V option selection.

Table 14. 525 – 690V, NEMA Type 12 Drive

Frame Size	Delivery Code	hp (I _H)	Current (I _H)	hp (I _L)	Current (I _L)	Catalog Number	Price U.S. \$
FR6	F1	2	3.33	3	4.5	SVX002A2-5A4N1	
		3	4.5	—	5.5	SVX003A2-5A4N1	
		—	5.5	5	7.5	SVX004A2-5A4N1	
		5	7.5	7-1/2	10	SVX005A2-5A4N1	
		7-1/2	10	10	13.5	SVX007A2-5A4N1	
		10	13.5	15	18	SVX010A2-5A4N1	
		15	18	20	22	SVX015A2-5A4N1	
		20	22	25	27	SVX020A2-5A4N1	
		25	27	30	34	SVX025A2-5A4N1	
		FR7	FP	30	34	40	
40	41			50	52	SVX040A2-5A4N1	
FR8	FP	50	52	60	62	SVX050A2-5A4N1	
		60	62	75	80	SVX060A2-5A4N1	
		75	80	100	100	SVX075A2-5A4N1	
FR9	FP	100	100	125	125	SVX100A2-5A4N1	
		125	125	150	144	SVX125A2-5A4N1	
		150	144	—	170	SVX150A2-5A4N1	
		—	170	200	208	SVX175A2-5A4N1	

Open Drives

Table 15. 525 – 690V, NEMA Type 12 Freestanding Drive

Frame Size	Delivery Code	hp (I _H)	Current (I _H)	hp (I _L)	Current (I _L)	Catalog Number	Price U.S. \$
FR10	FP	200	208	250	261	SPX200A2-5A4N1	
		250	261	300	325	SPX250A2-5A4N1	
		300	325	400	385	SPX300A2-5A4N1	

Note: Integrated fuses as standard. Limited option selection available; 115V Transformer (KB), Light Kit (L1), HOA (K4), Speed Potentiometer w/HOA (K2), Disconnect Switch (P2). See Enclosed 480V option selection.

Table 16. 525 – 690V, Open Chassis Drive

Frame Size	Delivery Code	hp (I _H)	Current (I _H)	hp (I _L)	Current (I _L)	Catalog Number	Price U.S. \$
FR10	FP	200	208	250	261	SPX200A0-5A2N1	
		250	261	300	325	SPX250A0-5A2N1	
		300	325	400	385	SPX300A0-5A2N1	
FR11	FP	400	385	450	460	SPX400A0-5A2N1	
		450	460	500	502	SPX450A0-5A2N1	
		500	502	—	590	SPX500A0-5A2N1	
FR12	FP	—	590	600	650	SPX550A0-5A2N1	
		600	650	700	750	SPX600A0-5A2N1	
		700	750	800	820	SPX700A0-5A2N1	
FR13	FP	800	820	900	920	SPX800A0-5A2N1	
		900	920	1000	1030	SPX900A0-5A2N1	
		1000	1030	1250	1180	SPXH10A0-5A2N1	
FR14	FP	1350	1300	1500	1500	SPXH13A0-5A2N1	
		1500	1500	2000	1900	SPXH15A0-5A2N1	
		2000	1900	2300	2250	SPXH20A0-5A2N1	

June 2006

Open Drives

9000X Series Option Board Kits

The 9000X Series drives can accommodate a wide selection of expander and adapter option boards to customize the drive for your application needs. The drive's control unit is designed to accept a total of five option boards (see Figure 1).

The 9000X Series factory installed standard board configuration includes an A9 I/O board and an A2 relay output board, which are installed in slots A and B.

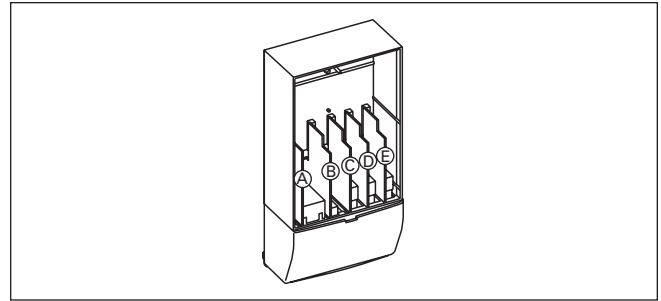

Figure 1. 9000X Series Option Boards

Table 17. Option Board Kits

Option Kit Description ②	Allowed Slot Locations ①	Field Installed		Factory Installed		SVX Ready Programs						
		Catalog Number	Price U.S. \$	Option Designator	Adder U.S. \$	Basic	Local/Remote	Standard	MSS	PID	Multi-P.	PFC
Standard I/O Cards (See Figure 1)												
2 RO (NC/NO)	B	OPTA2		—		X	X	X	X	X	X	X
6 DI, 1 DO, 2 AI, 1AO, 1 +10V DC ref, 2 ext +24V DC/ EXT +24V DC	A	OPTA9		—		X	X	X	X	X	X	X
Extended I/O Card Options												
2 RO, Therm — SPX Only	B	OPTA3		A3		—	X	X	X	X	X	X
Encoder low volt +5V/15V/24V — SPX Only	C	OPTA4		A4		—	X	X	X	X	X	X
Encoder high volt +15V/24V — SPX Only	C	OPTA5		A5		—	X	X	X	X	X	X
Double encoder — SPX Only	C	OPTA7		A7		X	X	X	X	X	X	X
6 DI, 1 DO, 2 AI, 1 AO — SPX Only	A	OPTA8		A8		—	X	X	X	X	X	X
3 DI (Encoder 10 – 24V), Out +15V/+24V, 2 DO (pulse+direction) — SPX Only	C	OPTAE		AE		X	X	X	X	X	X	X
6 DI, 1 ext +24V DC/EXT +24V DC	B, C, D, E	OPTB1		B1		—	—	—	—	—	X	X
1 RO (NC/NO), 1 RO (NO), 1 Therm	B, C, D, E	OPTB2		B2		—	—	—	—	—	X	X
1 AI (mA isolated), 2 AO (mA isolated), 1 ext +24V DC/EXT +24V DC	B, C, D, E	OPTB4		B4		X	X	X	X	X	X	X
3 RO (NO)	B, C, D, E	OPTB5		B5		—	—	—	—	—	X	X
1 ext +24V DC/EXT +24V DC, 3 Pt100	B, C, D, E	OPTB8		B8		—	—	—	—	—	—	—
1 RO (NO), 5 DI 42 – 240V AC Input	B,C, D, E	OPTB9		B9		—	—	—	—	—	X	X
Communication Cards												
Modbus ③	D, E	OPTC2		C2		X	X	X	X	X	X	X
Johnson Controls N2 ③	D, E	OPTC2		CA		—	—	—	—	—	—	—
Modbus TCP	D, E	OPTCI		CI		X	X	X	X	X	X	X
BACnet	D, E	OPTCJ		CJ		X	X	X	X	X	X	X
Ethernet IP	D, E	OPTCK		CK		X	X	X	X	X	X	X
Profibus DP	D, E	OPTC3		C3		X	X	X	X	X	X	X
LonWorks	D, E	OPTC4		C4		X	X	X	X	X	X	X
Profibus DP (D9 Connector)	D, E	OPTC5		C5		X	X	X	X	X	X	X
CanOpen (Slave) ④	D, E	OPTC6		C6		X	X	X	X	X	X	X
DeviceNet	D, E	OPTC7		C7		X	X	X	X	X	X	X
Modbus (D9 Type Connector)	D, E	OPTC8		C8		X	X	X	X	X	X	X
Adapter — SPX Only	D, E	OPTD1		D1		X	X	X	X	X	X	X
Adapter — SPX Only	D, E	OPTD2		D2		X	X	X	X	X	X	X
RS-232 with D9 Connection	D, E	OPTD3		D3		X	X	X	X	X	X	X
Keypad												
9000X Series Local/ Remote Keypad (Replacement Keypad)	—	KEYPAD-LOC/REM		—		—	—	—	—	—	—	—
9000X Series Remote Mount Keypad Unit (Keypad not included, includes 10 ft. cable, keypad holder, mounting hardware)	—	OPTRMT-KIT-9000X		—		—	—	—	—	—	—	—
9000X Series RS-232 Cable, 13 ft.	—	PP00104		—		—	—	—	—	—	—	—

① Option card must be installed in one of the slots listed for that card. Slot indicated in Bold is the preferred location.

② AI = Analog Input; AO = Analog Output, DI = Digital Input, DO = Digital Output, RO = Relay Output

③ OPTC2 is a multi-protocol option card.

④ SPX9000 Drives only (FR10 and larger).

Discount Symbol **SS-2**

Open Drives

Modbus RTU Network Communications

The Modbus Network Card OPTC2 is used for connecting the 9000X Drive as a slave on a Modbus network. The interface is connected by a 9-pin DSUB connector (female) and the baud rate ranges from 300 to 19200 baud. Other communication parameters include an address range from 1 to 247; a parity of None, Odd or Even; and the stop bit is 1.

Profibus Network Communications

The Profibus Network Card OPTC3 is used for connecting the 9000X Drive as a slave on a Profibus-DP network. The interface is connected by a 9-pin DSUB connector (female). The baud rates range from 9.6K baud to 12M baud, and the addresses range from 1 to 127.

LonWorks Network Communications

The LonWorks Network Card OPTC4 is used for connecting the 9000X Drive on a LonWorks network. This interface uses Standard Network Variable Types (SNVT) as data types. The channel connection is achieved using a FTT-10A Free Topology transceiver via a single twisted transfer cable. The communication speed with LonWorks is 78 kBits/s.

CanOpen (Slave) Communications

The CanOpen (Slave) Network Card OPTC6 is used for connecting the 9000X Drive to a host system. According to ISO11898 standard cables to be chosen for CAN bus should have a nominal impedance of 120Ω, and specific line delay of nominal 5 nS/m. 120Ω line termination resistors required for installation.

DeviceNet Network Communications

The DeviceNet Network Card OPTC7 is used for connecting the 9000X Drive on a DeviceNet Network. It includes a 5.08 mm pluggable connector. Transfer method is via CAN using a 2-wire twisted shielded cable with 2-wire bus power cable and drain. The baud rates used for communication include 125K baud, 250K baud and 500K baud.

Johnson Controls Metasys™ N2 Network Communications

The OPTC2 fieldbus board provides communication between the 9000X Drive and a Johnson Controls Metasys™ N2 network. With this connection, the drive can be controlled, monitored and programmed from the Metasys system. The N2 fieldbus is available as a factory installed option and as a field installable kit.

Modbus/TCP Network Communications

The Modbus/TCP Network Card OPTCI is used for connecting the 9000X Drive to Ethernet networks utilizing Modbus protocol. It includes an RJ-45 pluggable connector. This interface provides a selection of standard and custom register values to communicate drive parameters. The board supports 10 Mbps and 100 Mbps communication speeds. The IP address of the board is configurable over Ethernet using a supplied software tool.

BACnet Network Communications

The BACnet Network Card OPTCJ is used for connecting the 9000X Drive to BACnet networks. It includes a 5.08 mm pluggable connector. Data transfer is Master-Slave/Token Passing (MS/TP) RS-485. This interface uses a collection of 30 Binary Value Objects (BVOs) and 35 Analog Value Objects (AVOs) to communicate drive parameters. The card supports 9.6, 19.2 and 38.4 Kbaud communication speeds and supports network addresses 1 – 127.

Ethernet/IP Network Communications

The Ethernet/IP Network Card OPTCK is used for connecting the 9000X Drive to Ethernet/Industrial Protocol networks. It includes an RJ-45 pluggable connector. The interface uses CIP objects to communicate drive parameters (CIP is "Common Industrial Protocol", the same protocol used by DeviceNet). The board supports 10 Mbps and 100 Mbps communication speeds. The IP address of the board is configurable by Static, BOOTP and DHCP methods.

Options

Control Panel Options

Table 18. Control Panel Factory Options

Description	Factory Installed		Field Installed	
	Option Code	Adder U.S. \$	NEMA Type 1	
			Catalog Number	Price U.S. \$
Local/Remote Keypad SVX9000 Control Panel — This option is standard on all drives and consists of an RS-232 connection, backlit alphanumeric LCD display with nine indicators for the RUN status and two indicators for the control source. The nine pushbuttons on the panel are used for panel programming and monitoring of all SVX9000 parameters. The panel is detachable and isolated from the input line potential. Include LOC/REM key to choose control location.	A		KEYPAD-LOC/REM	
Keypad Remote Mounting Kit — This option is used to remote mount the SVX9000 keypad. The footprint is compatible to the SV9000 remote mount kit. Includes 10 ft. cable, keypad holder and mounting hardware.	—		OPTRMT-KIT-9000X	

Table 19. Miscellaneous Options

Description	Catalog Number	Price U.S. \$
9000XDrive — A PC-based tool for controlling and monitoring of the SVX9000. Features include: loading parameters that can be saved to a file or printed, setting references, starting and stopping the motor, monitoring signals in graphical or text form, and real-time display. To avoid damage to the drive or computer, SVDrivecable must be used.	9000XDRIVE	
SVDrivecable — 6 ft. (1.8m) RS-232 cable (22 gauge) with a 7-pin connector on each end. Should be used in conjunction with the 9000X Drive option to avoid damage to the SVX9000 or computer. The same cable can be used for downloading specialized applications to the drive.	SVDRIVECABLE	
External Dynamic Braking Resistors — Used with the Dynamic Braking Chopper Circuit to absorb motor regenerative energy for stopping the load and to dissipate the energy flowing back into the drive. Resistors are separated into Standard Duty and Heavy-Duty. Standard Duty is defined as 20% duty or less with 100% braking torque, while Heavy-Duty is defined as 50% duty or less with 150% braking torque. <i>Consult factory.</i>	①	

① Consult factory.

Brake Chopper Options

The Brake Chopper Circuit option is used for applications that require dynamic braking. Dynamic Braking resistors are not included with drive purchase. Consult the factory for dynamic braking resistors which are supplied separately. Resistors are not UL Listed.

Table 20. Brake Chopper Circuit Adder — NEMA Type 1, NEMA Type 12, Chassis

hp (H)	Adder U.S. \$		
	208 – 240V	380 – 500V	525 – 690V
2			
3			
5vt			
5ct			
7-1/2vt			
7-1/2ct			
10			
15			
20			
25			
30			
40			
50			
60			
75			
100			
125			
150			

hp (H)	Adder U.S. \$		
	208 – 240V	380 – 500V	525 – 690V
200vt			
200ct			
250			
300			
350			
400			
450			
500			
550			
600vt			
600ct			
700vt			
700ct			
800			
900			
1000			
1200			
1350			
1500			
1600			
2000			

Note: Delivery code is FP.

Table 21. Conformal (Varnished) Coating Adder — 208 – 240V, 380 – 500V, 525 – 690V (See Catalog Number Description to order.)

Frame	Delivery Code	Adder U.S. \$
FR4	FP	
FR5	FP	
FR6	FP	
FR7	FP	
FR8	FP	
FR9	FP	
FR10	FP	
FR11	FP	
FR12	FP	
FR13	FP	
FR14	FP	

Table 22. Conformal Coated Board Kits ②

Field Installed		Factory Installed	
Catalog Number	Price U.S. \$	Option Designator	Adder U.S. \$
OPT_V ④		③	

- ② See Option Catalog Numbers on Page 11.
- ③ Construct Catalog Numbers for factory installed per Table 4 on Page 6.
- ④ Replace “_” with the correct Catalog Number from Page 11. Example: OPTC2V.

Discount Symbol..... SS-2

Open Drives

Accessories

Demo Drive and Power Supply

Table 23. Demo Drive and Power Supply

Description	Catalog Number	Price U.S. \$
9000X Drive Demo	9000XDEMO	
Hand Held 24V Auxiliary Power Supply — used to supply power to the control module in order to perform keypad programming before the drive is connected to line voltage	9000XAUX24V	

NEMA Type 12 Conversion Kit

The NEMA Type 12 kit option is used to convert a NEMA Type 1 to a NEMA Type 12 drive. The NEMA Type 12 Kit consists of a metal drive shroud, fan kit for some frames, adaptor plate and plugs.

Table 24. NEMA Type 12 Conversion Kit

Frame Size	Delivery Code	Approximate Dimensions in Inches (mm)			Approximate Weight in Lb. (kg)	Catalog Number	Price U.S. \$
		Length	Width	Height	Weight		
FR4	W	13 (330)	7 (178)	4 (102)	4 (1.8)	OPTN12FR4	
FR5	W	16 (406)	8 (203)	7 (178)	5 (2.3)	OPTN12FR5	
FR6	W	21 (533)	10 (254)	5 (127)	7 (3.2)	OPTN12FR6	

Flange Kits

Flange Kit Type 12

The flange kit is utilized when the power section is mounted through the back panel of an enclosure. Includes flange mount brackets and NEMA Type 12 fan components. Metal shroud not included.

Table 25. Flange Kit Type 12 — Frames 4, 5 and 6 ①

Frame Size	Delivery Code	Catalog Number	Price U.S. \$
FR4	W	OPTTHRFR4	
FR5	W	OPTTHRFR5	
FR6	W	OPTTHRFR6	

① For installation of an SVX9000 NEMA Type 1 drive into a NEMA Type 12 oversized enclosure.

Flange Kit Type 1

Flange kits for NEMA 1 enclosure drive rating are determined by rating of drive.

Table 26. Flange Kit Type 1 — Frames 4 – 9 ②

Frame Size	Delivery Code	Catalog Number	Price U.S. \$
FR4	FP	OPTTHR4	
FR5	FP	OPTTHR5	
FR6	FP	OPTTHR6	
FR7	FP	OPTTHR7	
FR8	FP	OPTTHR8	
FR9	FP	OPTTHR9	

② For installation of an SVX9000 NEMA Type 1 drive into a NEMA Type 1 oversized enclosure.

Flange Kit Type 12

Flange kits for NEMA 12 enclosure drive rating are determined by rating of drive.

Table 27. Flange Kit Type 12 — Frames 4 – 9 ③

Frame Size	Delivery Code	Catalog Number	Price U.S. \$
FR4	FP	OPTTHR4	
FR5	FP	OPTTHR5	
FR6	FP	OPTTHR6	
FR7	FP	OPTTHR7	
FR8	FP	OPTTHR8	
FR9	FP	OPTTHR9	

③ For installation of an SVX9000 NEMA Type 12 drive into a NEMA Type 12 oversized enclosure.

June 2006

Open Drives

Dimensions

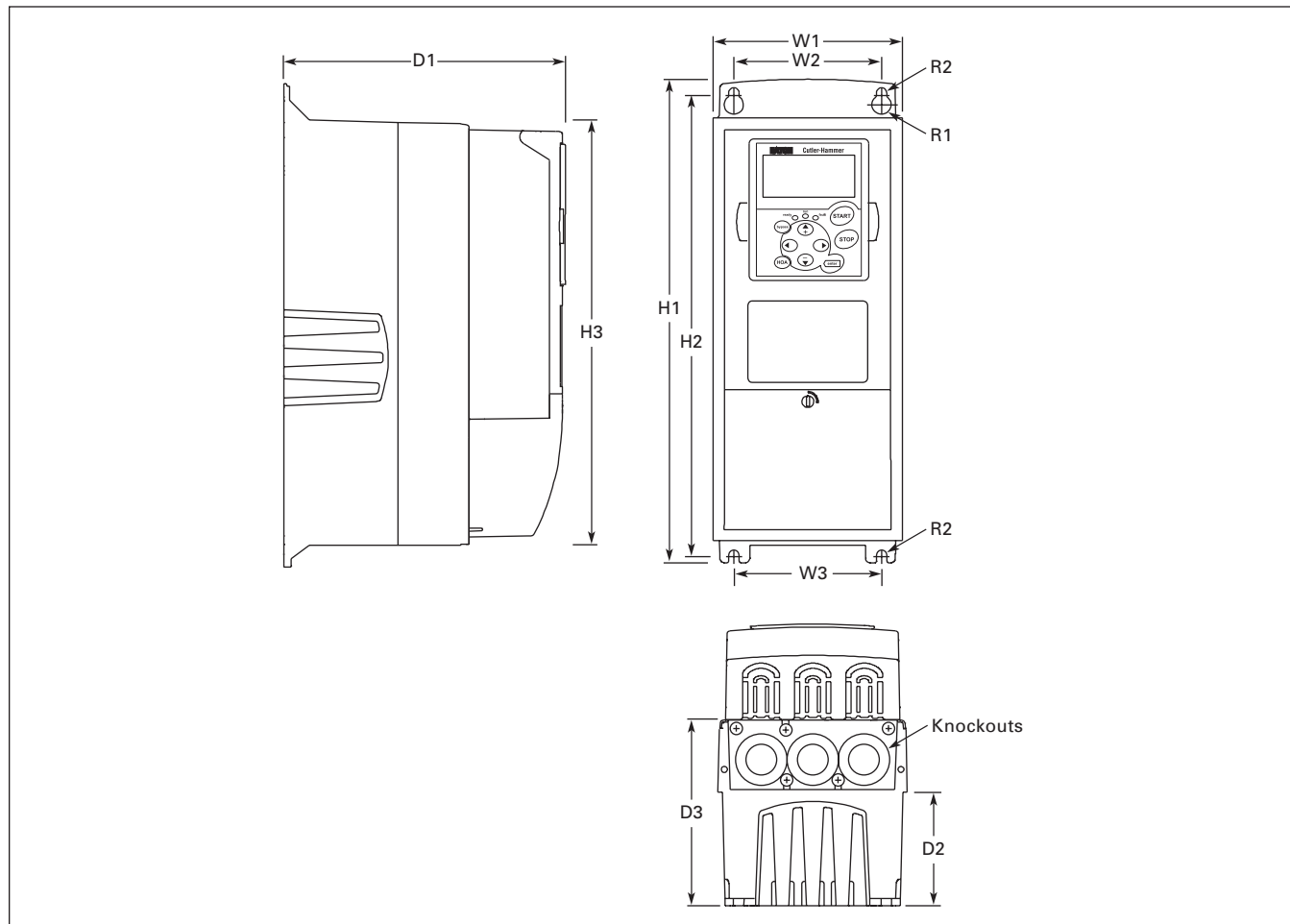

Figure 2. NEMA Type 1 and NEMA Type 12 9000X Drive Dimensions, FR4, FR5 and FR6

Table 28. 9000X Drive Dimensions

Frame Size	Voltage	hp (I _H)	Approximate Dimensions in Inches (mm)											Weight Lbs. (kg)	Knockouts @ Inches (mm) N1 (O.D.)
			H1	H2	H3	D1	D2	D3	W1	W2	W3	R1 dia.	R2 dia.		
FR4	230V	3/4 – 3	12.9	12.3	11.5	7.5	3.0	5.0	5.0	3.9	—	.5	.3	11.0	3 @ 1.1
	480V	1 – 5	(327)	(313)	(292)	(190)	(77)	(126)	(128)	(100)		(13)	(7)	(5)	(28)
FR5	230V	5 – 7-1/2	16.5	16.0	15.3	8.4	3.9	5.8	5.6	3.9	—	.5	.3	17.9	2 @ 1.5
	480V	7-1/2 – 15	(419)	(406)	(389)	(214)	(100)	(148)	(143)	(100)		(13)	(7)	(8)	1 @ 1.1 (28)
FR6	230V	10 – 15	22.0	21.3	20.4	9.3	4.2	6.5	7.6	5.8	—	.6	.4	40.8	3 @ 1.5
	480V	20 – 30	(558)	(541)	(519)	(237)	(105)	(165)	(195)	(148)		(15.5)	(9)	(19)	(37)
	575V	2 – 25													

Open Drives

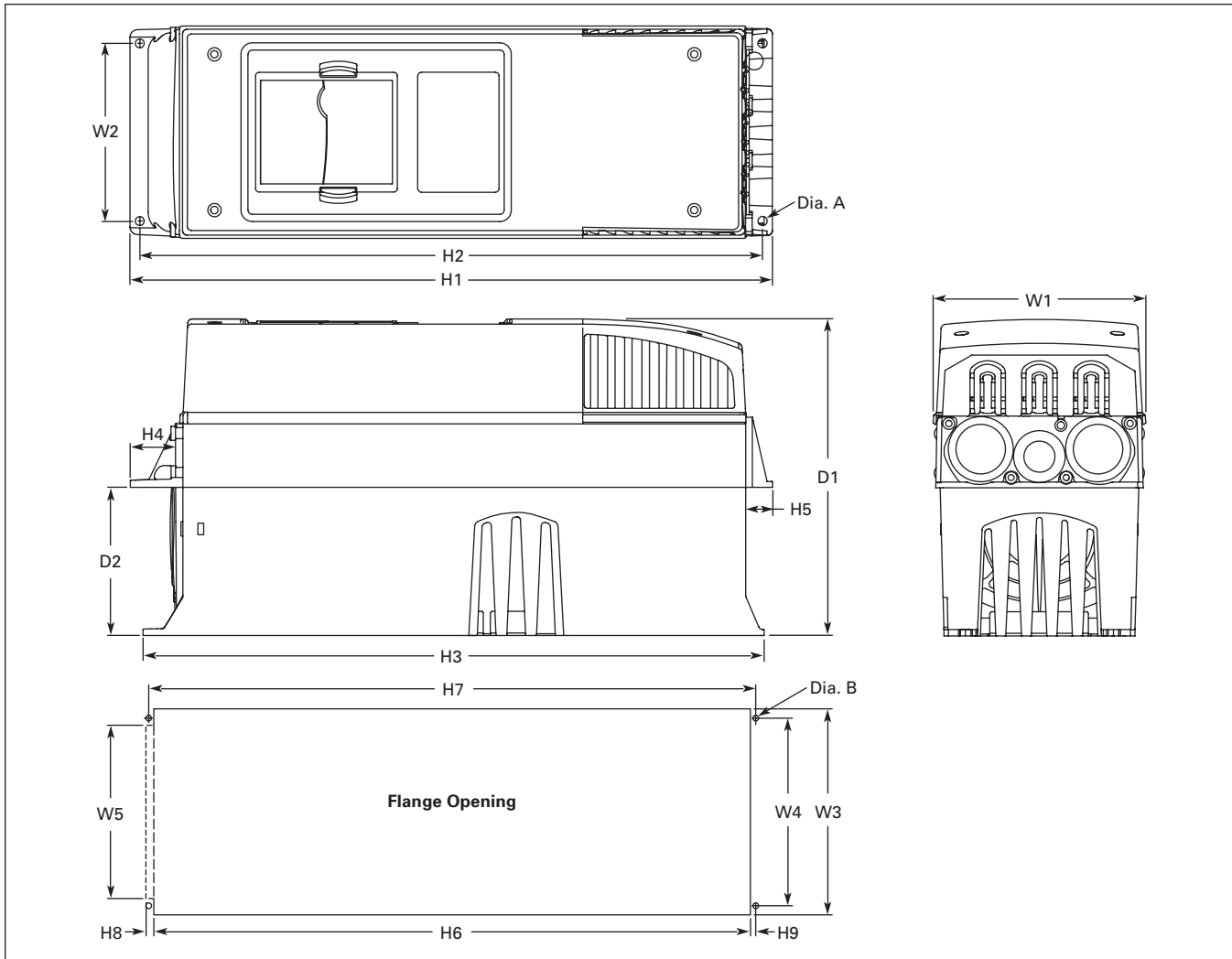

Figure 3. 9000X Dimensions, NEMA Type 1 and NEMA Type 12 with Flange Kit, FR4, FR5 and FR6

Table 29. Dimensions for 9000X, FR4, FR5 and FR6 with Flange Kit

Frame Size	Approximate Dimensions in Inches (mm)									
	W1	W2	H1	H2	H3	H4	H5	D1	D2	Dia. A
FR4	5.0 (128)	4.5 (113)	13.3 (337)	12.8 (325)	12.9 (327)	1.2 (30)	.9 (22)	7.5 (190)	3.0 (77)	.3 (7)
FR5	5.6 (143)	4.7 (120)	17.0 (434)	16.5 (420)	16.5 (419)	1.4 (36)	.7 (18)	8.4 (214)	3.9 (100)	.3 (7)
FR6	7.7 (195)	6.7 (170)	22.0 (560)	21.6 (549)	22.0 (558)	1.2 (30)	.8 (20)	9.3 (237)	4.2 (106)	.3 (7)

Table 30. Dimensions for the Flange Opening, FR4 to FR6

Frame Size	Approximate Dimensions in Inches (mm)								
	W3	W4	W5	H6	H7	H8	H9	Dia. B	
FR4	4.8 (123)	4.5 (113)	—	12.4 (315)	12.8 (325)	—	.2 (5)	.3 (7)	
FR5	5.3 (135)	4.7 (120)	—	16.2 (410)	16.5 (420)	—	.2 (5)	.3 (7)	
FR6	7.3 (185)	6.7 (170)	6.2 (157)	21.2 (539)	21.6 (549)	.3 (7)	.2 (5)	.3 (7)	

June 2006

Open Drives

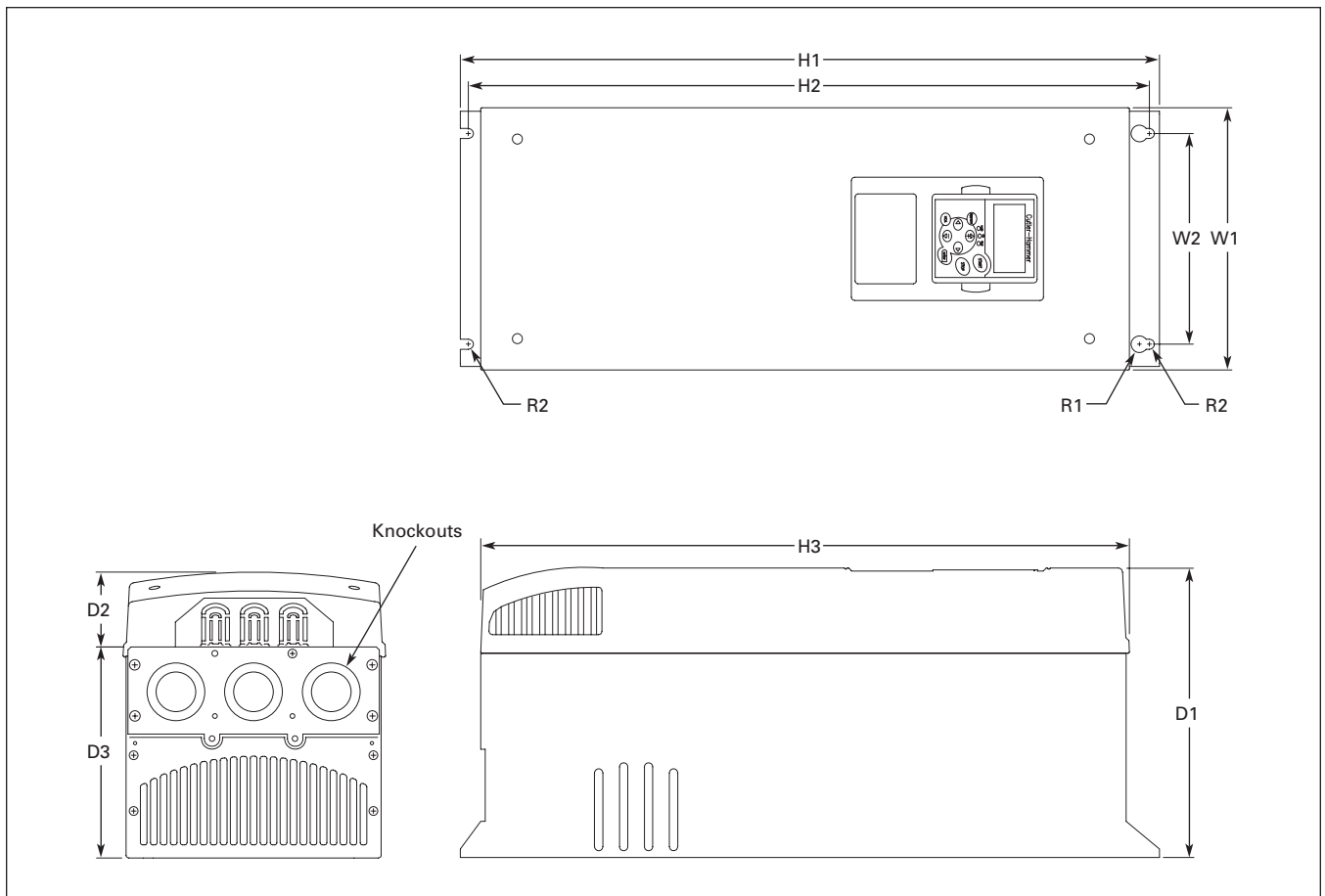

Figure 4. 9000X Dimensions, NEMA Type 1 and NEMA Type 12, FR7

Table 31. 9000X Drive Dimensions, FR7

Frame Size	Voltage	hp (I _H)	Approximate Dimensions in Inches (mm)										Weight lbs. (kg)	Knockouts @ Inches (mm) N1 (O.D.)
			H1	H2	H3	D1	D2	D3	W1	W2	R1 dia.	R2 dia.		
FR7	230V	20 – 30	24.8	24.2	23.2	10.1	3.0	7.3	9.3	7.5	.7	.4	77.2 (35)	3 @ 1.5 (37)
	480V	40 – 60	(630)	(614)	(590)	(257)	(77)	(184)	(237)	(190)	(18)	(9)		
	575V	30 – 40												

Open Drives

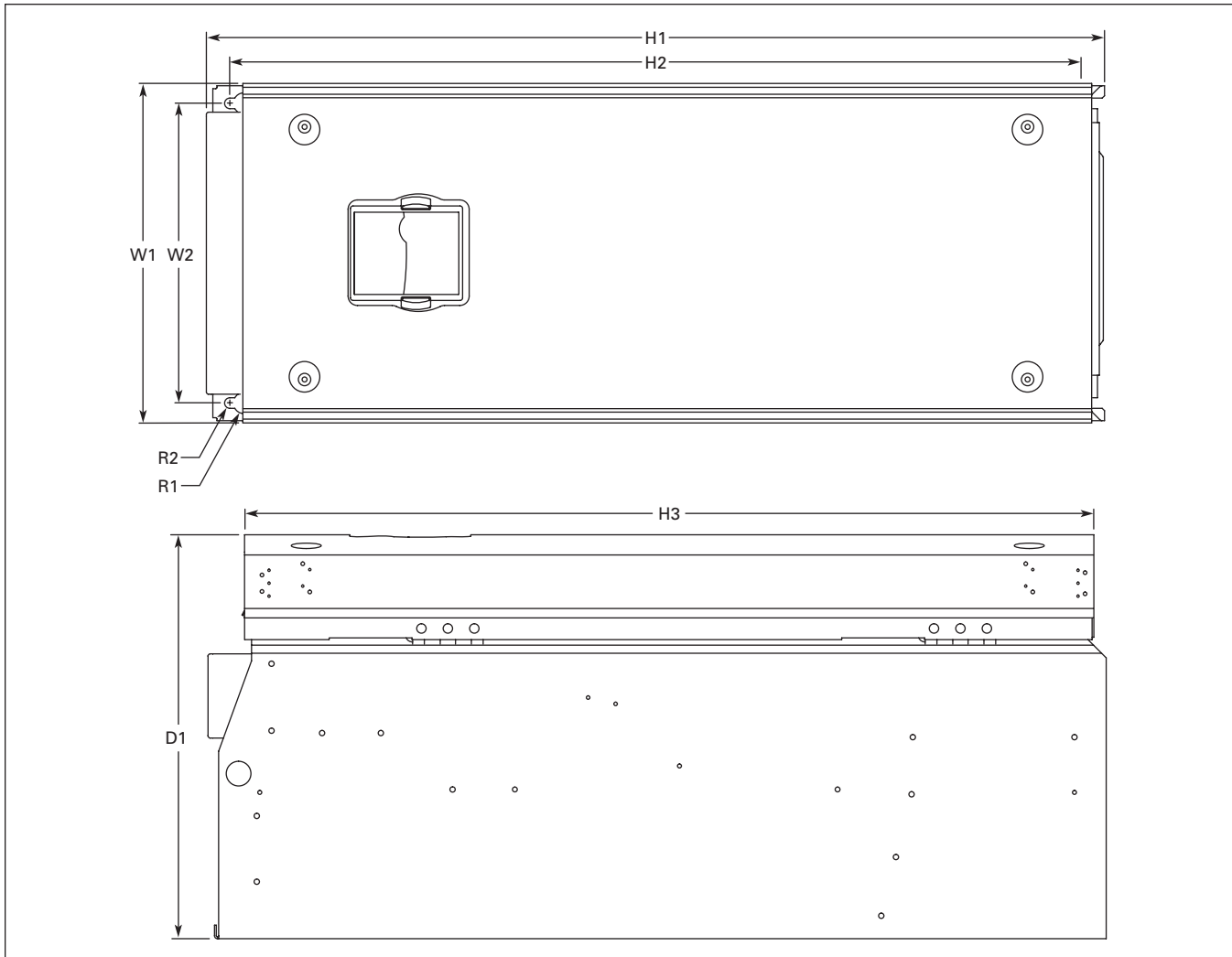

Figure 5. 9000X Dimensions, NEMA Type 1 and NEMA Type 12, FR8

Table 32. 9000X Drive Dimensions, FR8

Frame Size	Voltage	hp (I _H)	Approximate Dimensions in Inches (mm)								Weight lbs. (kg)
			D1	H1	H2	H3	W1	W2	R1 dia.	R2 dia.	
FR8	230V	40 – 60	13.5 (344)	30.1 (764)	28.8 (732)	28.4 (721)	11.5 (291)	10 (255)	.7 (18)	.4 (9)	127 (58)
	480V	75 – 125									
	575V	50 – 75									

June 2006

Open Drives

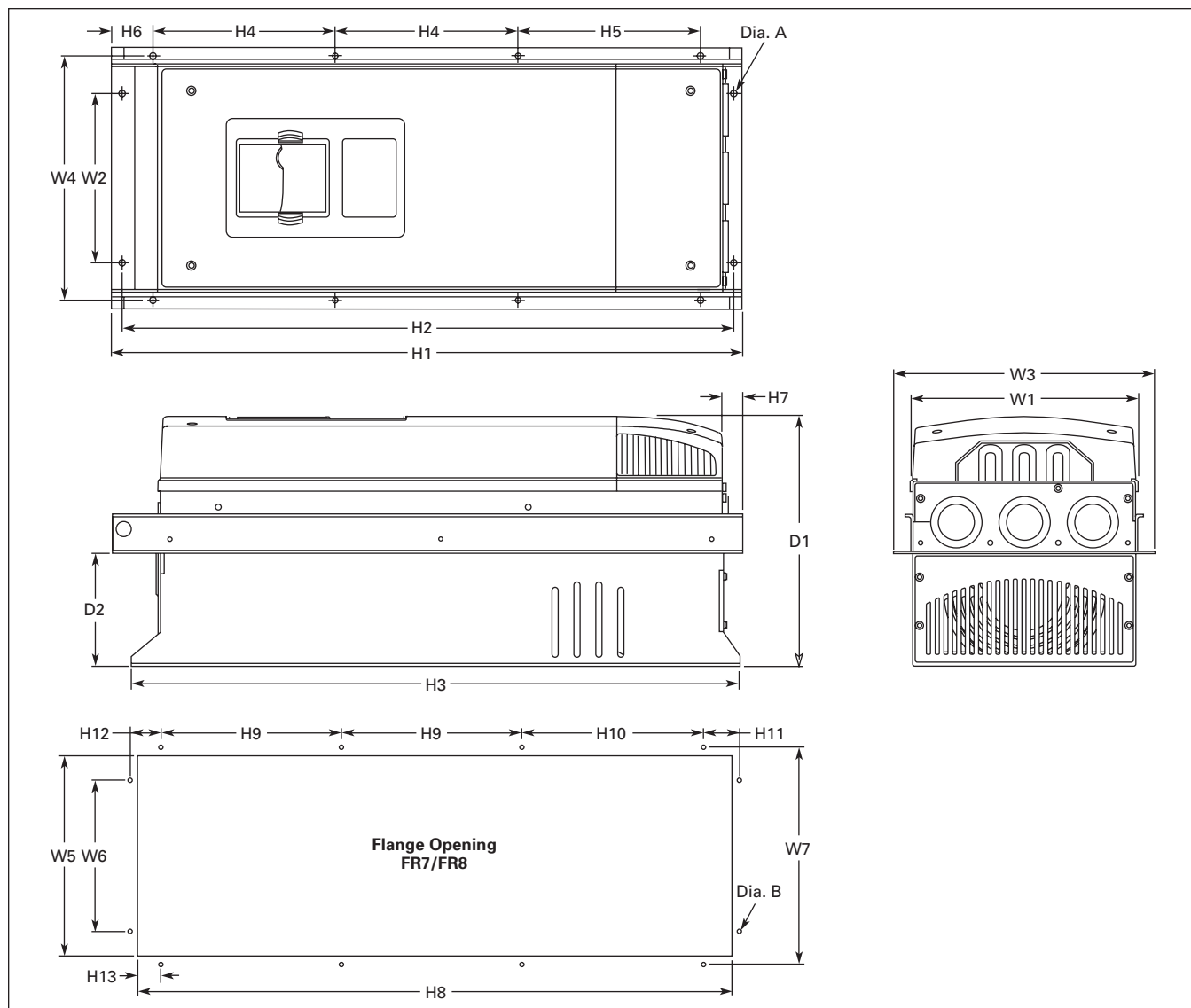

Figure 6. 9000X Dimensions, NEMA Type 1 and NEMA Type 12, with Flange Kit, FR7 and FR8

Table 33. Dimensions for 9000X, FR7 and FR8 with Flange Kit

Frame Size	Approximate Dimensions in Inches (mm)													
	W1	W2	W3	W4	H1	H2	H3	H4	H5	H6	H7	D1	D2	Dia. A
FR7	9.3 (237)	6.8 (175)	10.6 (270)	10.0 (253)	25.6 (652)	24.8 (632)	24.8 (630)	7.4 (189)	7.4 (189)	.9 (23)	.8 (20)	10.1 (257)	4.6 (117)	.3 (6)
FR8	11.2 (285)	—	14.0 (355)	13.0 (330)	32.8 (832)	—	29.3 (745)	10.2 (258)	10.4 (265)	1.7 (43)	2.2 (57)	13.5 (344)	4.3 (110)	.4 (9)

Table 34. Dimensions for the Flange Opening, FR7/FR8

Frame Size	Approximate Dimensions in Inches (mm)									
	W5	W6	W7	H8	H9	H10	H11	H12	H13	Dia. B
FR7	9.2 (233)	6.9 (175)	10.0 (253)	24.4 (619)	7.4 (189)	7.4 (189)	1.4 (35)	1.3 (32)	1.0 (25)	.3 (6)
FR8	11.9 (301)	—	13.0 (330)	31.9 (810)	10.2 (258)	10.4 (265)	—	—	1.3 (33)	.4 (9)

Open Drives

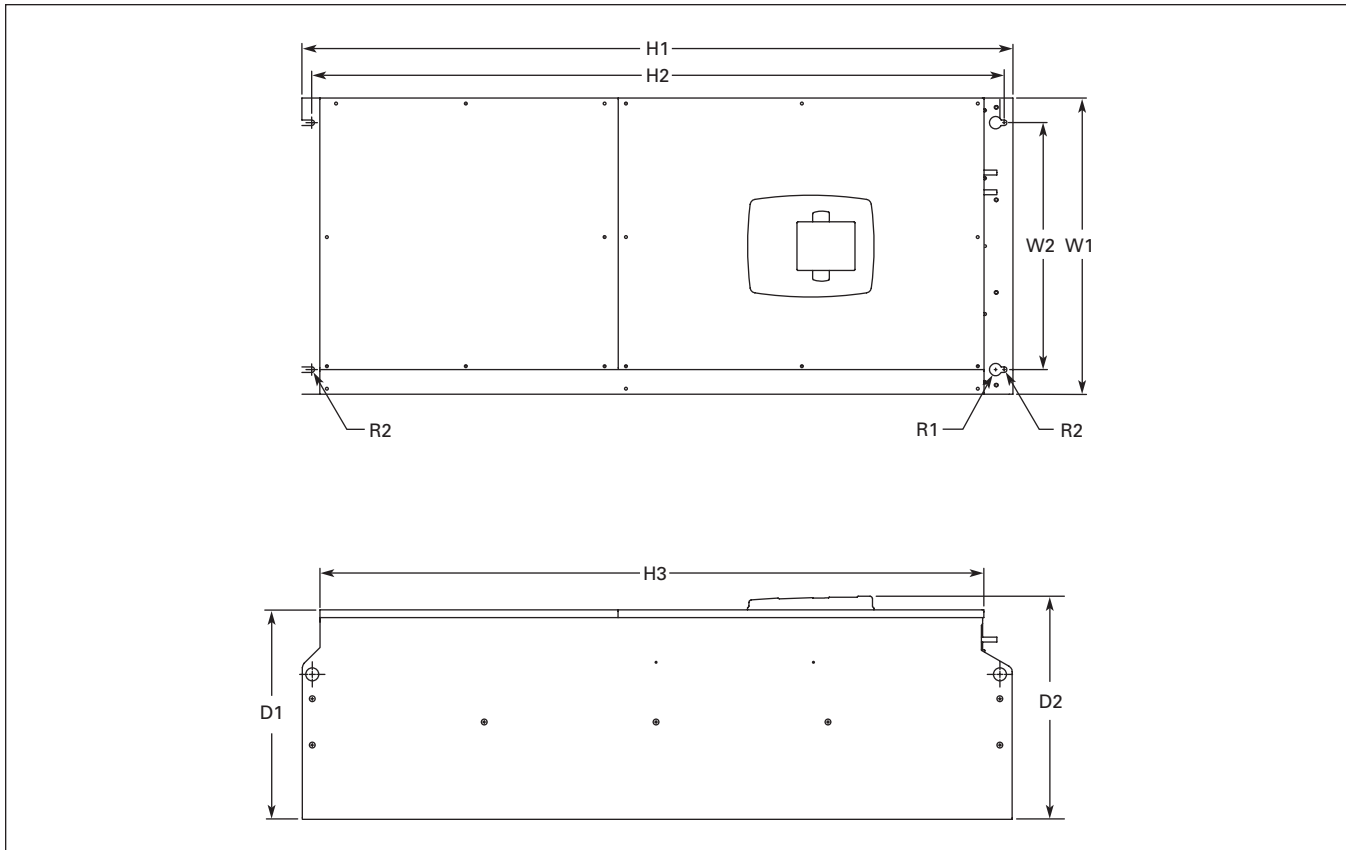

Figure 7. 9000X Dimensions, NEMA Type 1 and NEMA Type 12, FR9

Table 35. 9000X Drive Dimensions, FR9

Frame Size	Voltage	hp (I _H)	Approximate Dimensions in Inches (mm)									Weight lbs. (kg)
			H1	H2	H3	D1	D2	W1	W2	R1 dia.	R2 dia.	
FR9	230V	75 – 100	45.3	44.1	42.4	13.4	14.3	18.9	15.7	.8	.4	321.9 (146)
	480V	150 – 200	(1150)	(1120)	(1076)	(340)	(362)	(480)	(400)	(20)	(9)	
	575V	100 – 175										

June 2006

Open Drives

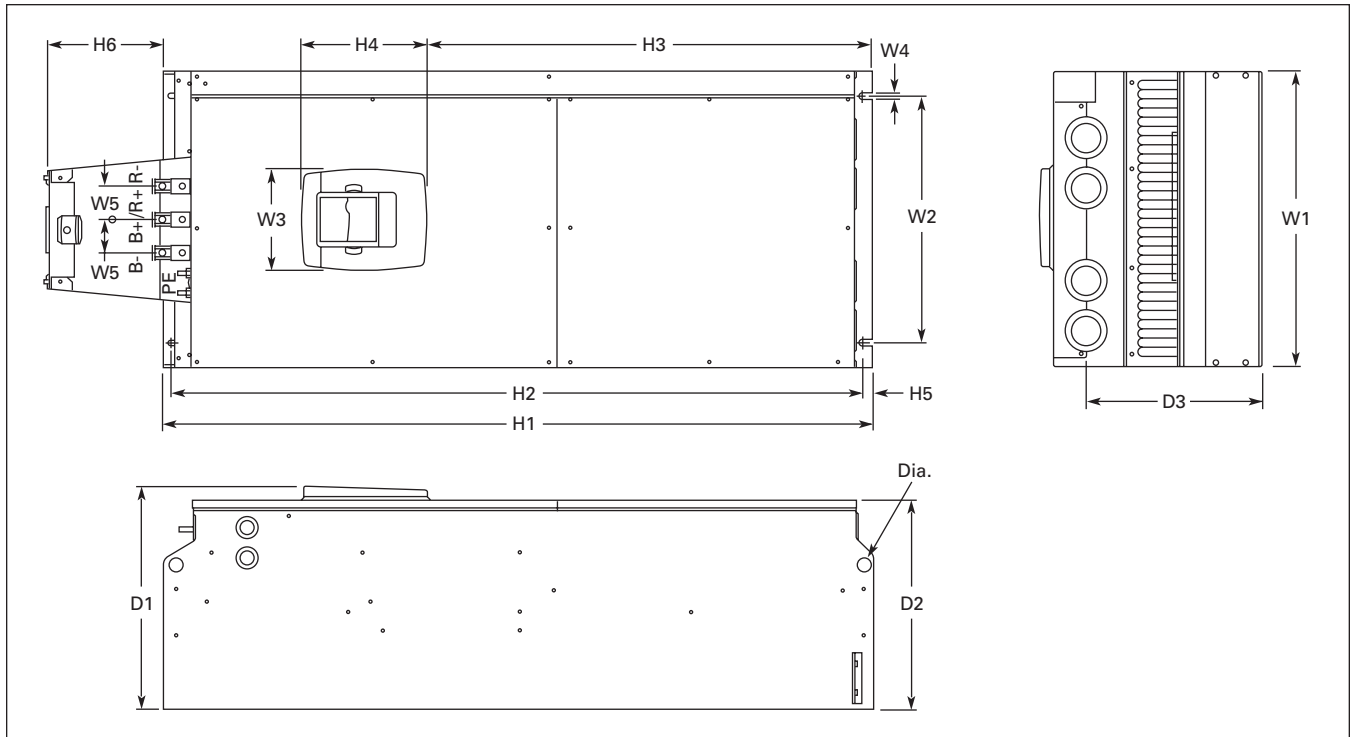

Figure 8. 9000X Dimensions, NEMA Type 1 and NEMA Type 12 FR9

Table 36. Dimensions for 9000X, FR9

Frame Size	Approximate Dimensions in Inches (mm)														
	W1	W2	W3	W4	W5	H1	H2	H3	H4	H5	H6 ①	D1	D2	D3	Dia.
FR9	18.9 (480)	15.7 (400)	6.5 (165)	.4 (9)	2.1 (54)	45.3 (1150)	44.1 (1120)	28.3 (721)	8.0 (205)	.6 (16)	7.4 (188)	14.2 (361.5)	13.4 (340)	11.2 (285)	.8 (21)

① Brake resistor terminal box (H6) included when brake chopper ordered.

Open Drives

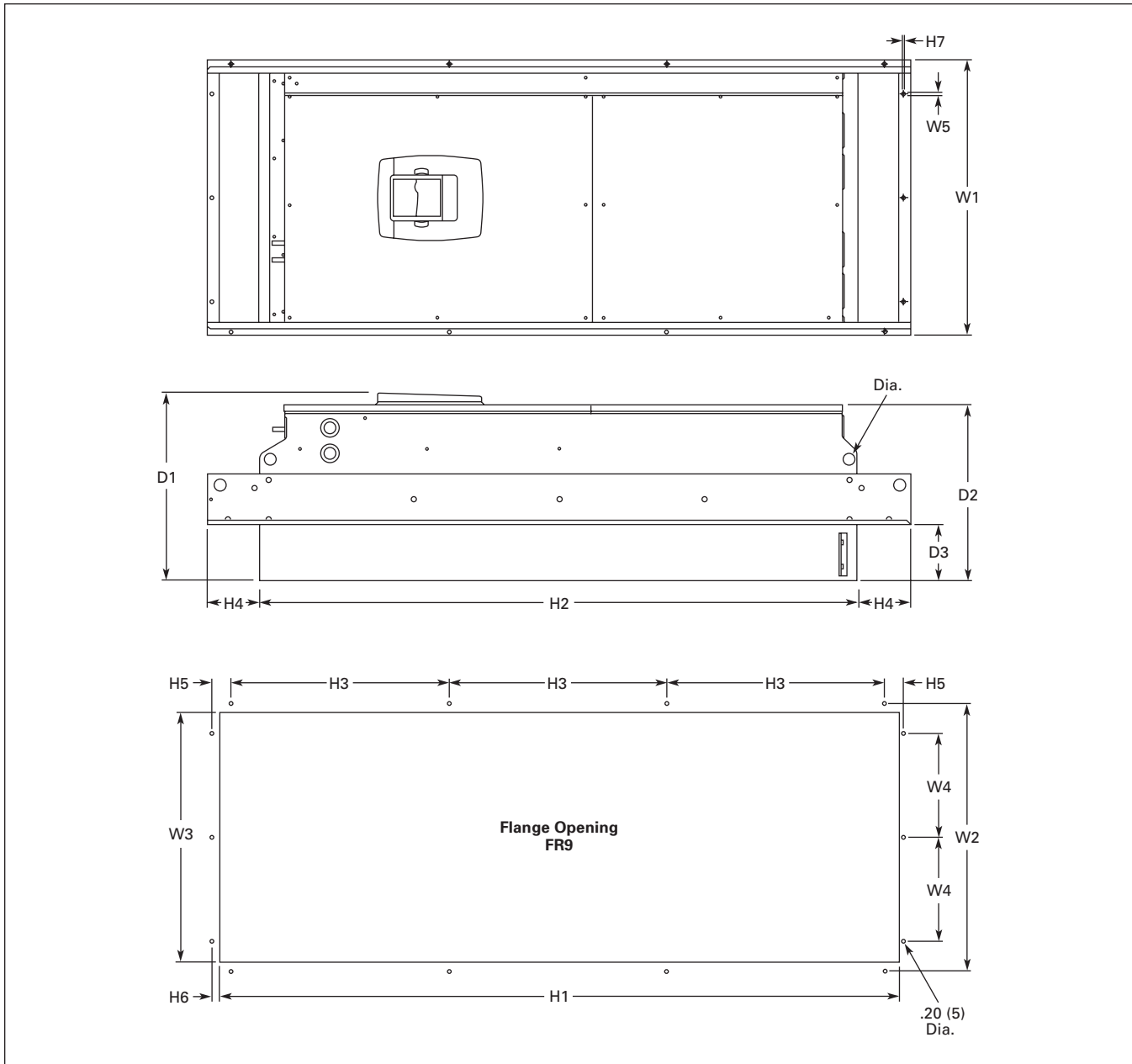

Figure 9. 9000X Dimensions, NEMA Type 1 and NEMA Type 12 FR9 with Flange Kit

Table 37. Dimensions for 9000X, FR9 with Flange Kit

Frame Size	Approximate Dimensions in Inches (mm)															
	W1	W2	W3	W4	W5	H1	H2	H3	H4	H5	H6	H7	D1	D2	D3	Dia.
FR9	20.9 (530)	20.0 (510)	19.1 (485)	7.9 (200)	.2 (5.5)	51.7 (1312)	45.3 (1150)	16.5 (420)	3.9 (100)	1.4 (35)	.4 (9)	.1 (2)	24.9 (362)	13.4 (340)	4.3 (109)	.8 (21)

June 2006

Open Drives

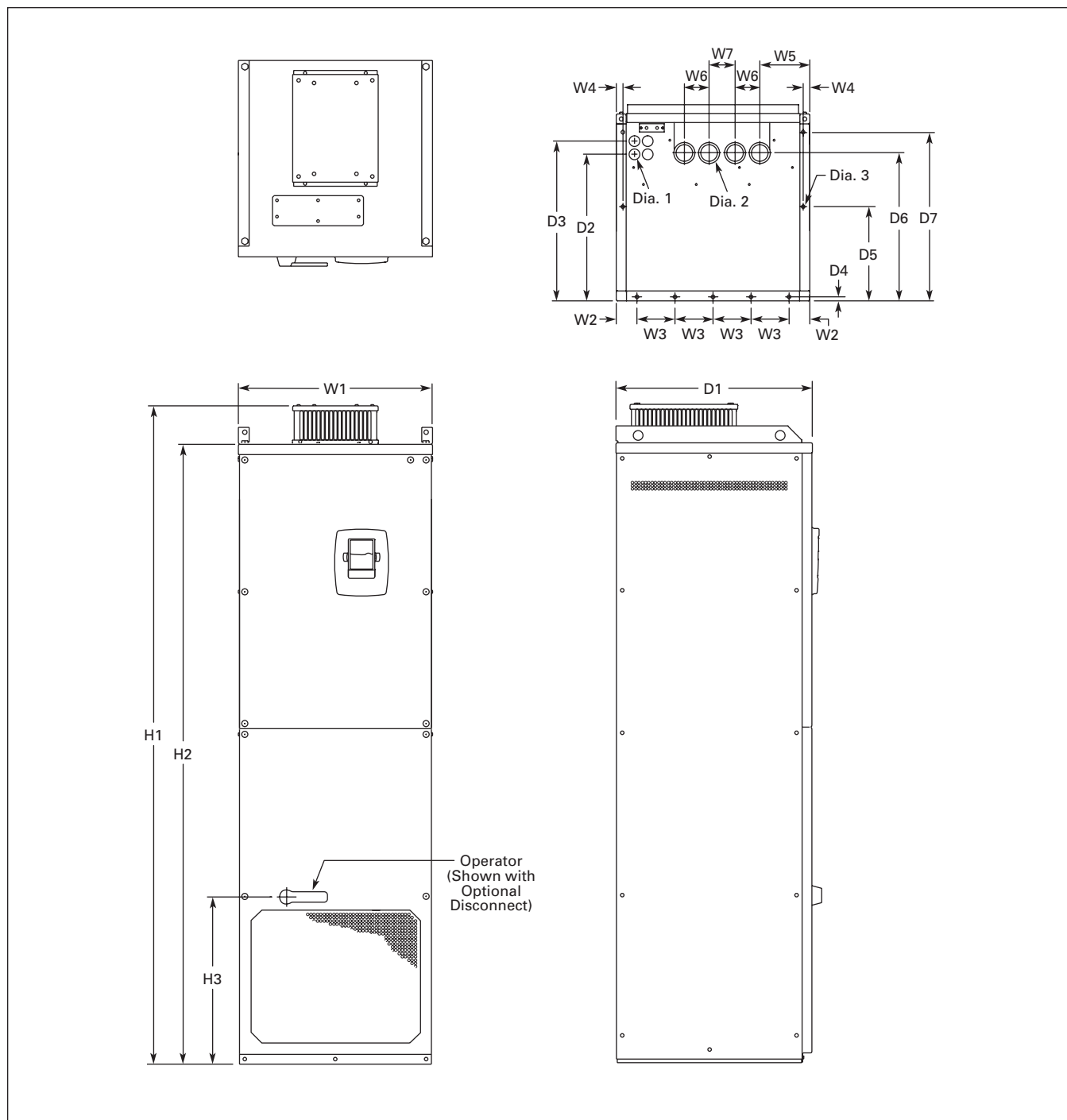

Figure 10. 9000X Dimensions, NEMA Type 1 and NEMA Type 12 FR10 Freestanding Drive

Table 38. Dimensions for 9000X, FR10 Freestanding Drive

Frame Size	Approximate Dimensions in Inches (mm)																				Weight lbs. (kg)
	W1	W2	W3	W4	W5	W6	W7	H1	H2	H3	D1	D2	D3	D4	D5	D6	D7	Dia. 1	Dia. 2	Dia. 3	
FR10	23.43 (595)	2.46 (62.5)	4.53 (115)	.79 (20)	5.95 (151)	2.95 (75)	3.11 (79)	79.45 (2018)	74.80 (1900)	20.18 (512.5)	23.70 (602)	17.44 (443)	19.02 (483)	.47 (12)	11.22 (285)	17.60 (447)	20.08 (510)	.83 (21)	1.89 (48)	.43 (11)	857 (389)

Open Drives

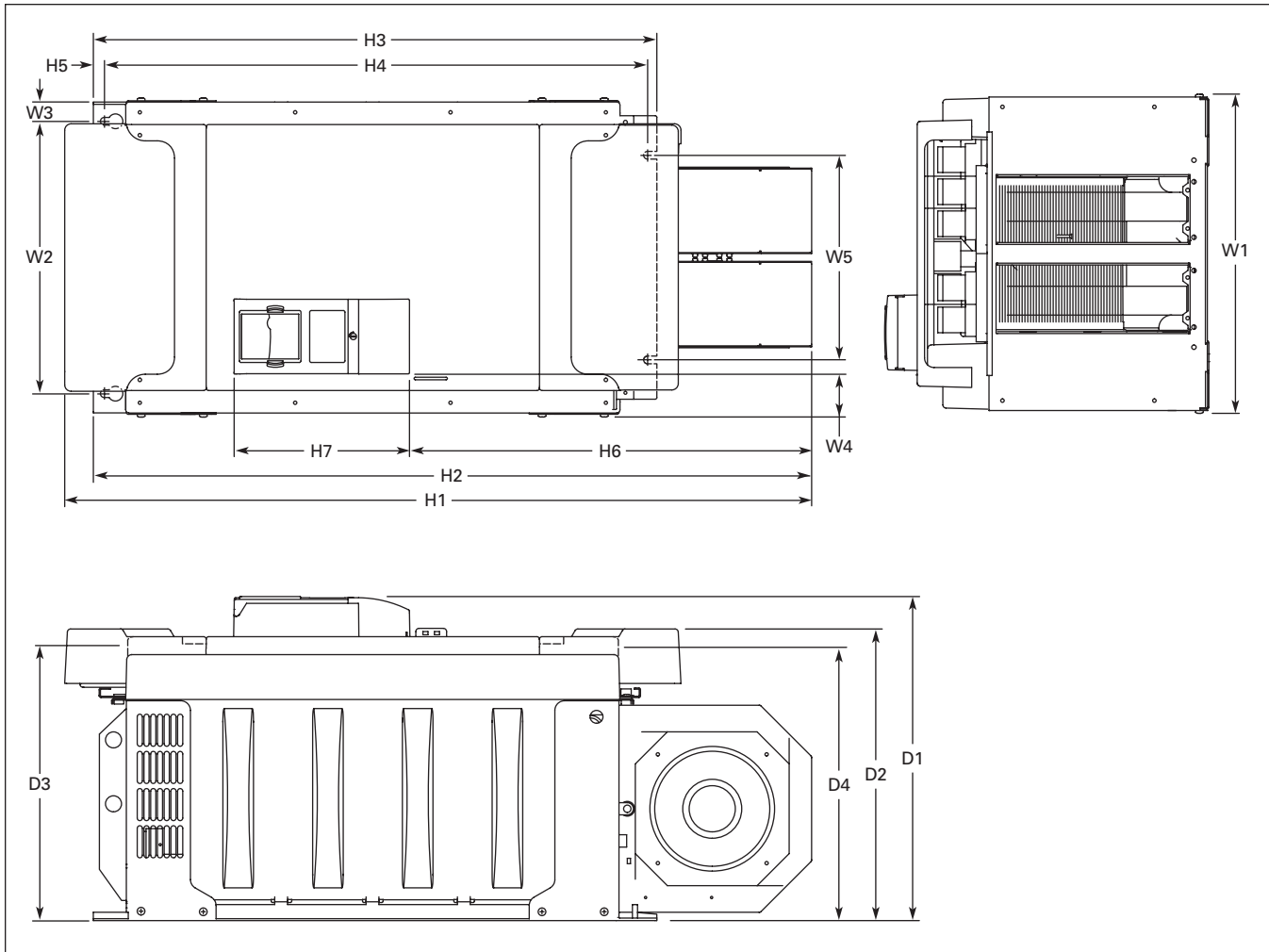

Figure 11. 9000X Dimensions, FR10 Open Chassis

Table 39. Dimensions for 9000X, FR10 Open Chassis

Frame Size	Voltage	hp (H)	Approximate Dimensions in Inches (mm)																Weight lbs. (kg)
			W1	W2	W3	W4	W5	H1	H2	H3	H4	H5	H6	H7	D1	D2	D3	D4	
FR10	480V	250 – 350	19.7	16.7	1.2	2.6	12.8	45.9	44.1	34.6	33.5	.7	24.7	10.8	19.9	17.9	16.7	16.6	518
	575V	200 – 300	(500)	(425)	(30)	(67)	(325)	(1165)	(1121)	(879)	(850)	(17)	(627)	(275)	(506)	(455)	(423)	(421)	(235)

Note: 9000X FR12 is built of two FR10 modules. Please refer to SPX9000 installation manual for mounting instructions.

June 2006

Open Drives

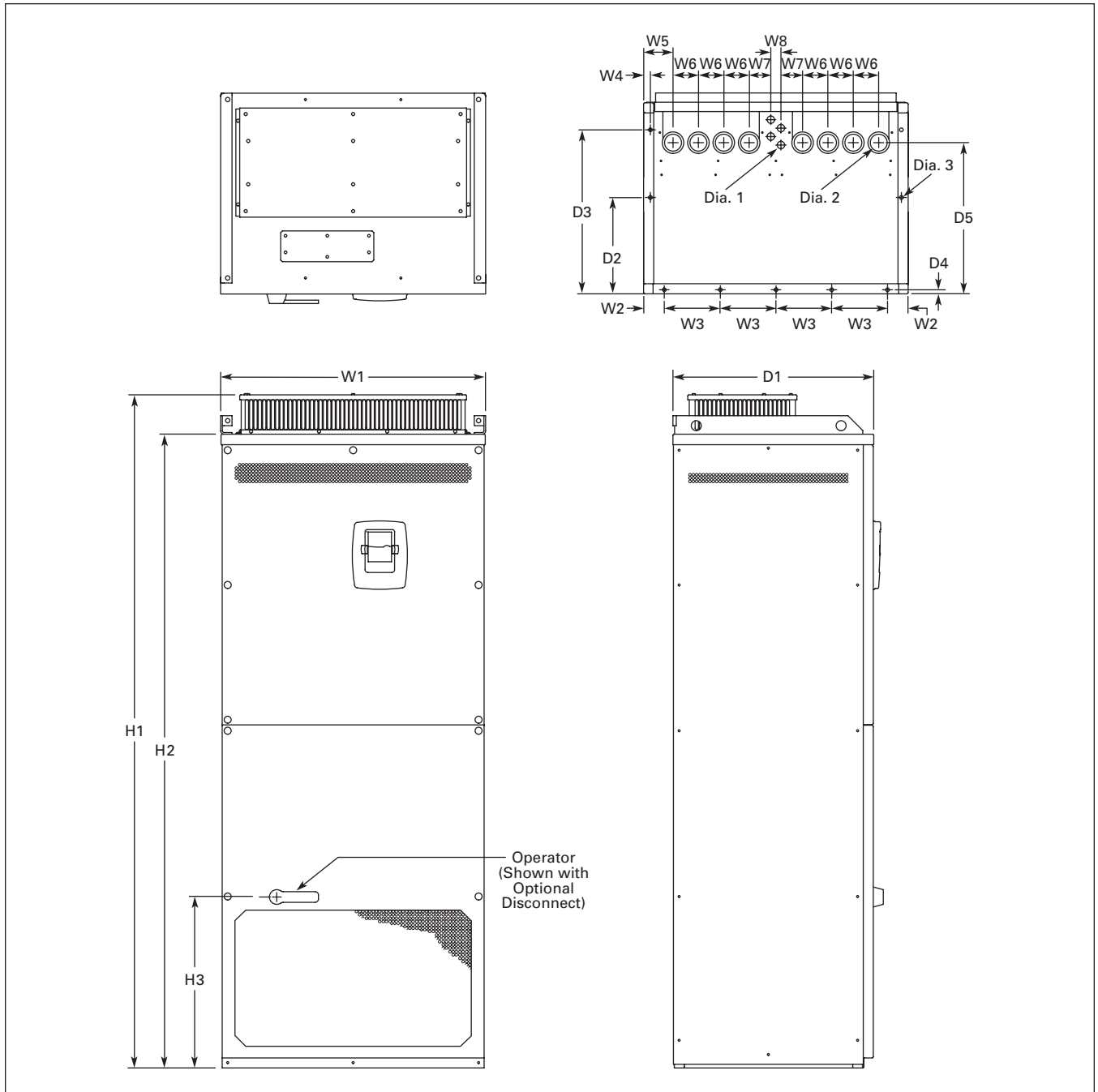

Figure 12. 9000X Dimensions, NEMA Type 1 FR11 Freestanding Drive

Table 40. Dimensions for 9000X, NEMA Type 1 FR11 Freestanding Drive

Frame Size	Voltage	hp (I _H)	Approximate Dimensions in Inches (mm)																		Weight lbs. (kg)	
			W1	W2	W3	W4	W5	W6	W7	W8	H1	H2	H3	D1	D2	D3	D4	D5	Dia. 1	Dia. 2		Dia. 3
FR11	480	400 – 550	31.26 (794)	2.40 (61)	6.50 (165)	.79 (20)	3.43 (87)	2.95 (75)	2.52 (64)	1.18 (30)	79.45 (2018)	74.80 (1900)	20.18 (512.5)	23.70 (602)	11.22 (285)	19.09 (485)	.47 (12)	17.60 (447)	.83 (21)	1.89 (48)	.35 x .43 (9 x 11)	526 (239)

Open Drives

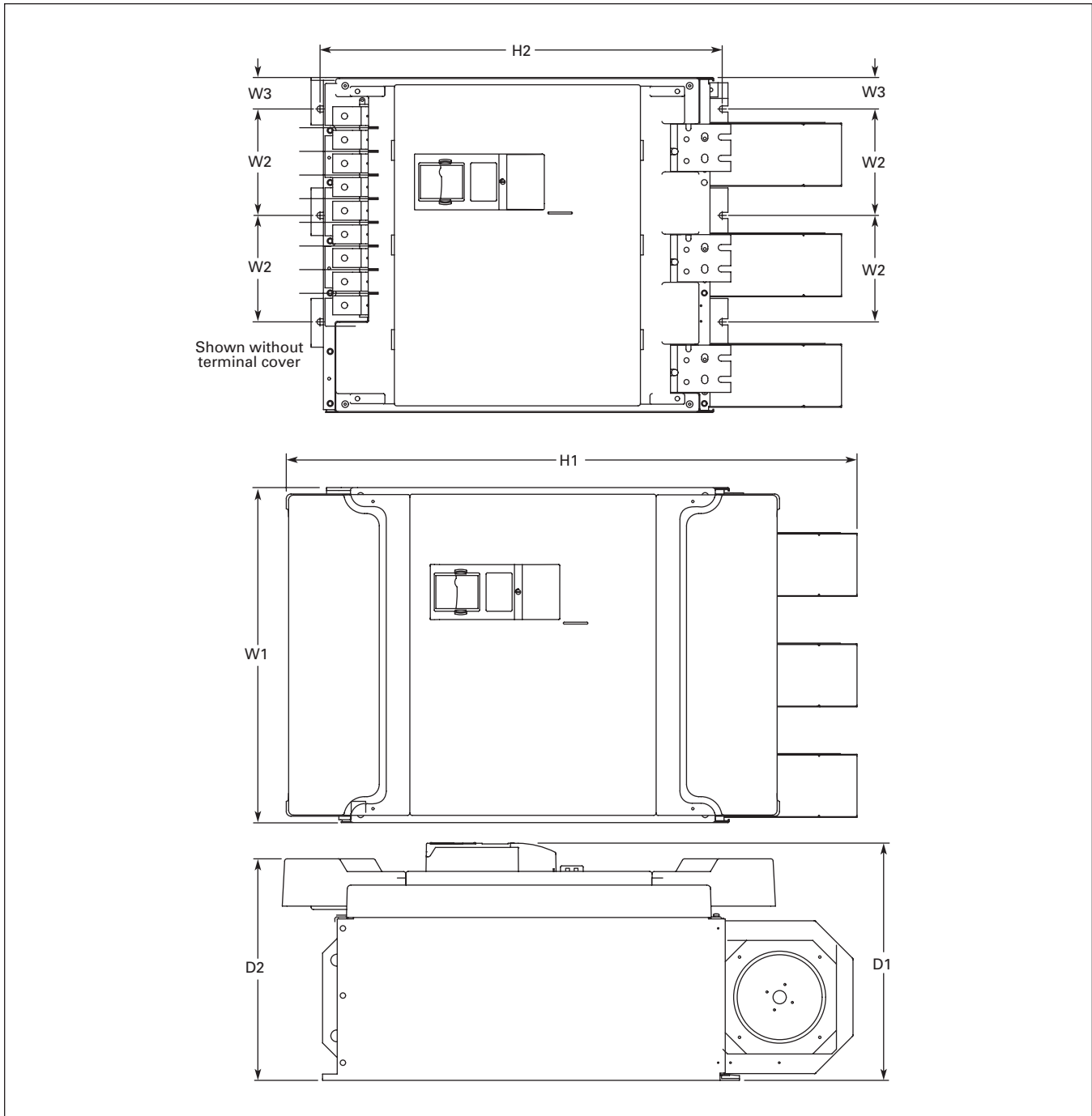

Figure 13. 9000X Dimensions, FR11 Open Chassis

Table 41. Dimensions for 9000X, FR11 Open Chassis

Frame Size	Voltage	hp (I _H)	Approximate Dimensions in Inches (mm)							Weight lbs. (kg)
			W1	W2	W3	H1	H2	D1	D2	
FR11	480V	400 – 550	27.9	8.86	2.6	45.5	33.5	19.8	18.4	833
	575V	400 – 500	(709)	(225)	(67)	(1155)	(850)	(503)	(468)	(378)

June 2006

Open Drives

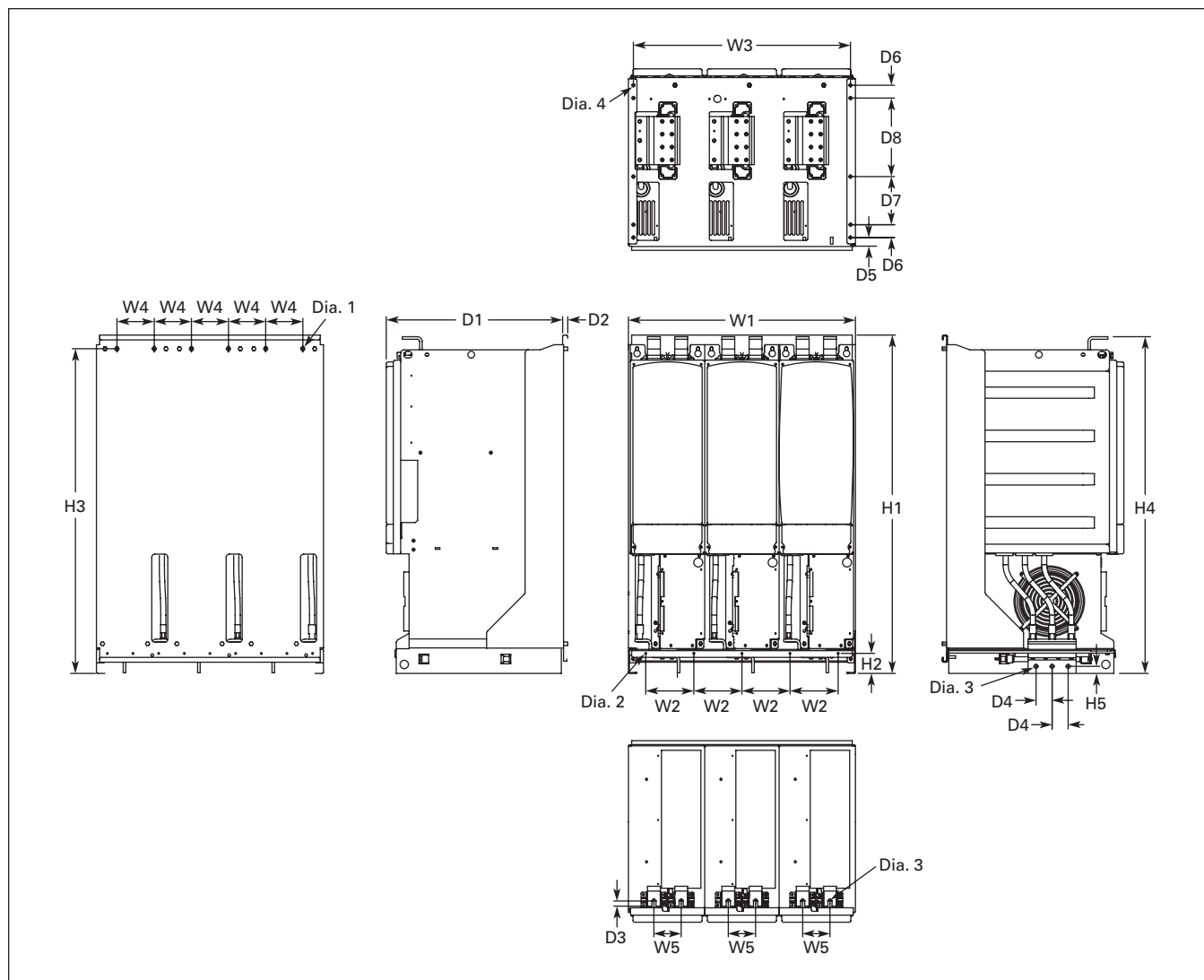

Figure 14. 9000X Dimensions, FR13 Open Chassis Inverter

Table 42. Dimensions for 9000X, FR13 Open Chassis Inverter

Frame Size	Approximate Dimensions in Inches (mm)																		Weight lbs. (kg)				
	W1	W2	W3	W4	W5	H1	H2	H3	H4	H5	D1	D2	D3	D4	D5	D6	D7	D8		Dia. 1	Dia. 2	Dia. 3	Dia. 4
FR13	27.87 (708)	5.91 (150)	26.65 (677)	4.57 (116)	3.35 (85)	41.54 (1055)	2.46 (62.5)	39.86 (1012.5)	41.34 (1050)	.79 (20)	21.77 (553)	.51 (13)	.63 (16)	1.97 (50)	1.06 (27)	1.57 (40)	5.91 (150)	9.64 (244.8)	.35x.59 (9x15)	.18 (4.6)	.51 (13)	.37 (9.5)	683 (310)

Note: 9000X FR14 is built of two FR13 modules. Please refer to SPX9000 installation manual for mounting instructions.

Note: FR13 is built from an inverter module and a converter module. Please refer to SPX9000 installation manual for mounting instructions.

Open Drives

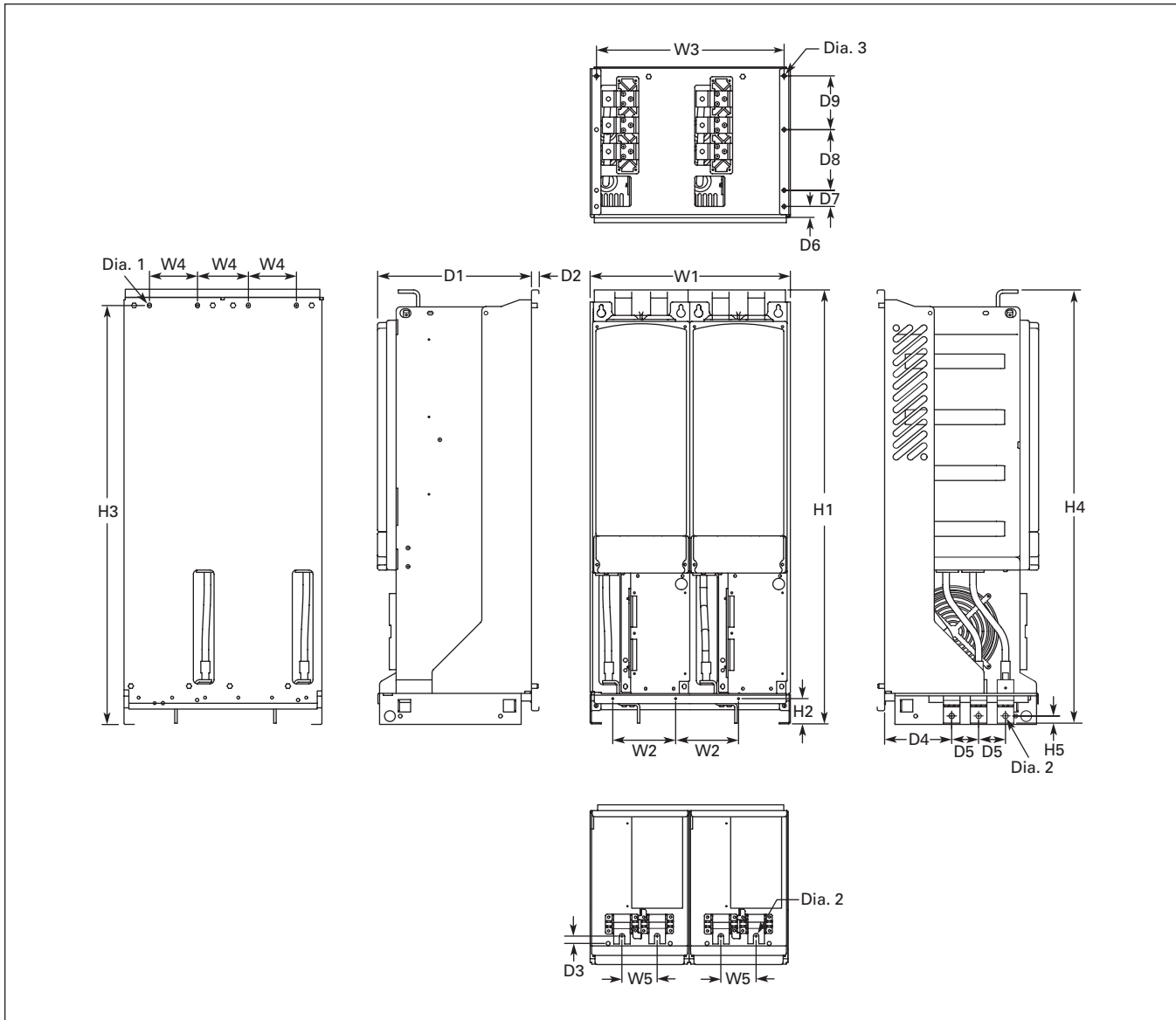

Figure 15. 9000X Dimensions, FR13 Open Chassis Converter

Table 43. FR13 — Number of Input Units

480V	hp	Input Modules	690V	hp	Input Modules
SPX800A0-4A2N1	800	2	SPX800A0-5A2N1	800	2
			SPX900A0-5A2N1	900	2
			SPXH10A0-5A2N1	1000	2

Table 44. Dimensions for 9000X, FR13 Open Chassis Converter

Frame Size	Approximate Dimensions in Inches (mm)																				Weight lbs. (kg)		
	W1	W2	W3	W4	W5	H1	H2	H3	H4	H5	D1	D2	D3	D4	D5	D6	D7	D8	D9	Dia. 1		Dia. 2	Dia. 3
FR13	18.74 (476)	5.91 (150)	17.52 (445)	4.57 (116)	3.35 (85)	41.54 (1055)	2.46 (62.5)	39.86 (1012.5)	41.34 (1050)	.69 (17.5)	14.69 (373)	.51 (13)	.73 (18.5)	6.42 (163)	2.56 (65)	1.06 (27)	1.57 (40)	5.91 (150)	5.24 (133)	.35x.59 (9x15)	.51 (13)	.37 (9.5)	295 (134)

June 2006

Open Drives

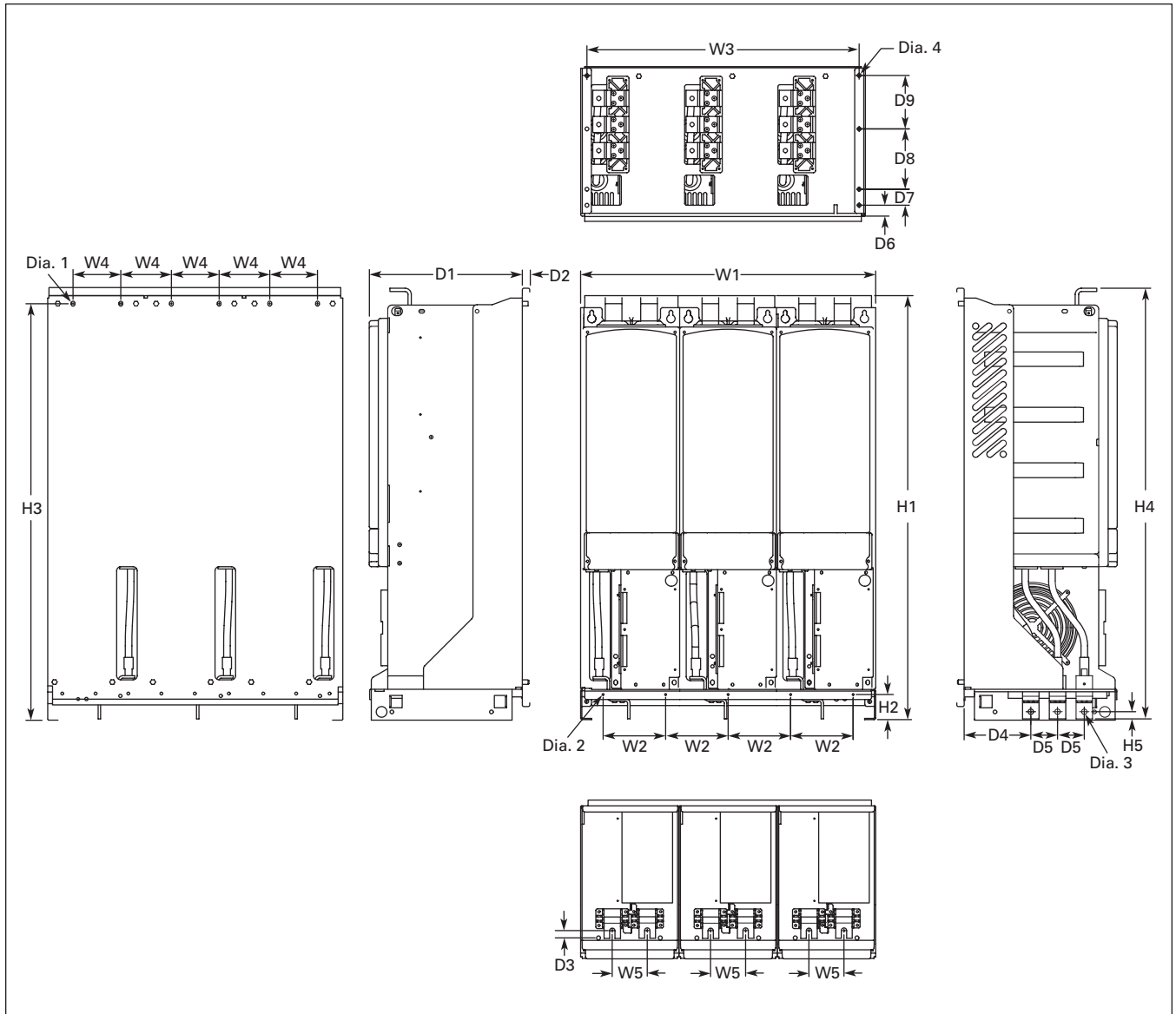

Figure 16. 9000X Dimensions, FR13 Open Chassis Converter — 900/1000 hp 480V

Table 45. FR13 — Number of Input Units

480V	hp	Input Modules
SPX900A0-4A2N1	900	3
SPXH10A0-4A2N1	1000	3

Table 46. Dimensions for 9000X, FR13 Open Chassis Converter — 900/1000 hp 480V

Frame Size	Approximate Dimensions in Inches (mm)																				Weight lbs. (kg)			
	W1	W2	W3	W4	W5	H1	H2	H3	H4	H5	D1	D2	D3	D4	D5	D6	D7	D8	D9	Dia. 1		Dia. 2	Dia. 3	Dia. 4
FR13	27.87 (708)	5.91 (150)	26.65 (677)	4.57 (116)	3.35 (85)	41.54 (1055)	2.46 (62.5)	39.86 (1012.5)	41.34 (1050)	.69 (17.5)	14.69 (373)	.51 (13)	.73 (18.5)	6.42 (163)	2.56 (65)	1.06 (27)	1.57 (40)	5.91 (150)	5.24 (133)	.35x.59 (9x15)	.18 (4.6)	.51 (13)	.37 (9.5)	443 (201)

Open Drives

Table 47. Choke Types

Catalog Number	Frame Size	Choke Type ①
Voltage Range 380 – 500V		
SPX 250 4	FR10	CHK0400
SPX 300 4	FR10	CHK0520
SPX 350 4	FR10	CHK0520
SPX 400 4	FR11	2 x CHK0400
SPX 500 4	FR11	2 x CHK0400
SPX 550 4	FR11	2 x CHK0400
SPX 600 4	FR12	2 x CHK0520
SPX 650 4	FR12	2 x CHK0520
SPX 700 4	FR12	2 x CHK0520
SPX 800 4	FR13	2 x CHK0400
SPX 900 4	FR13	3 x CHK0520
SPX H10 4	FR13	3 x CHK0520
SPX H12 4	FR14	4 x CHK0520
SPX H16 4	FR14	6 x CHK0400
Voltage Range 525 – 690V		
SPX 200 5	FR10	CHK0261
SPX 250 5	FR10	CHK0400
SPX 300 5	FR10	CHK0400
SPX 400 5	FR11	CHK0520
SPX 450 5	FR11	CHK0520
SPX 500 5	FR11	2 x CHK0400
SPX 550 5	FR12	2 x CHK0400
SPX 600 5	FR12	2 x CHK0400
SPX 700 5	FR12	2 x CHK0400
SPX 800 5	FR13	2 x CHK0400
SPX 900 5	FR13	2 x CHK0400
SPX H10 5	FR13	2 x CHK0400
SPX H13 5	FR14	4 x CHK0400
SPX H15 5	FR14	6 x CHK0400

① Chokes are provided with all FR10 – FR14 drives.

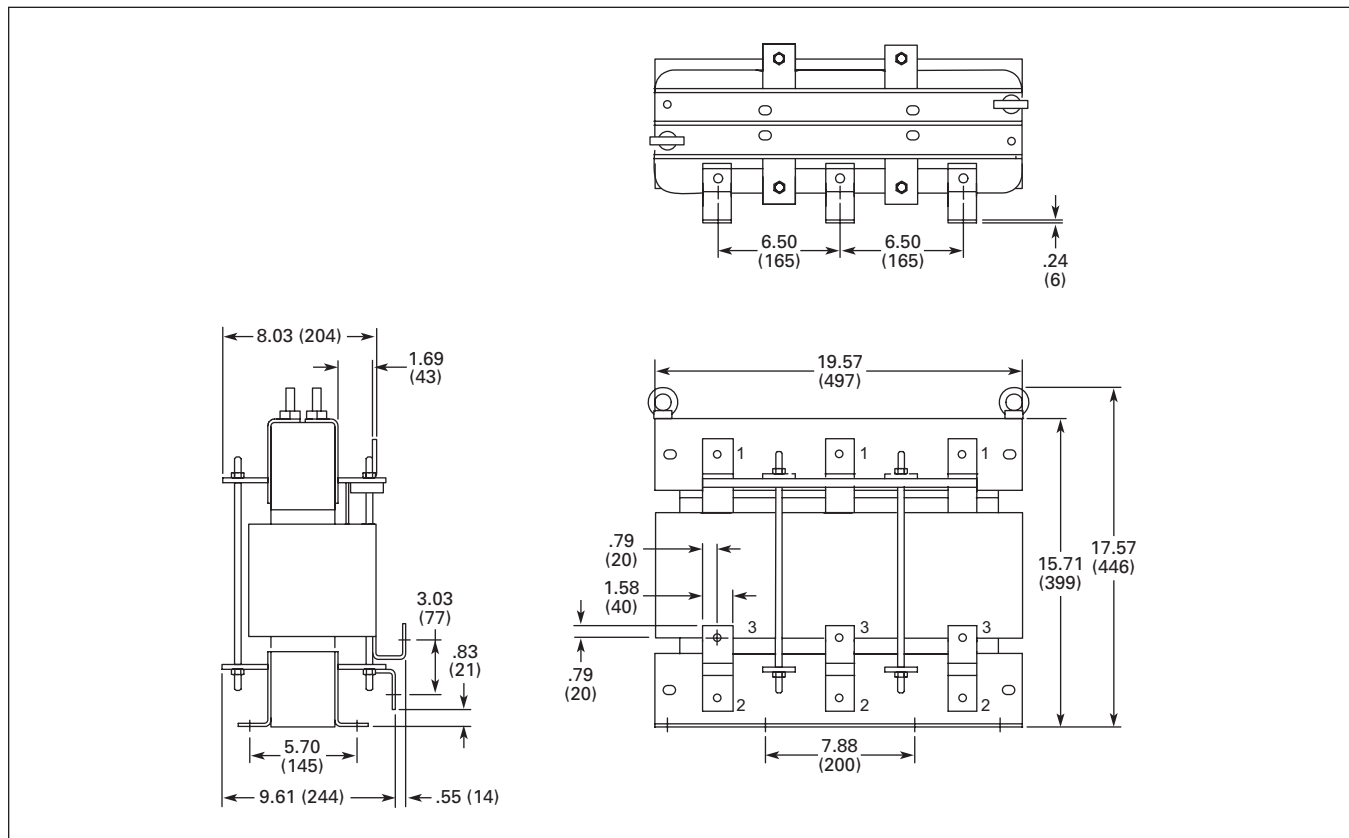

Figure 17. Dimensions of AC Choke CHK0520 in Inches (mm)

June 2006

Open Drives

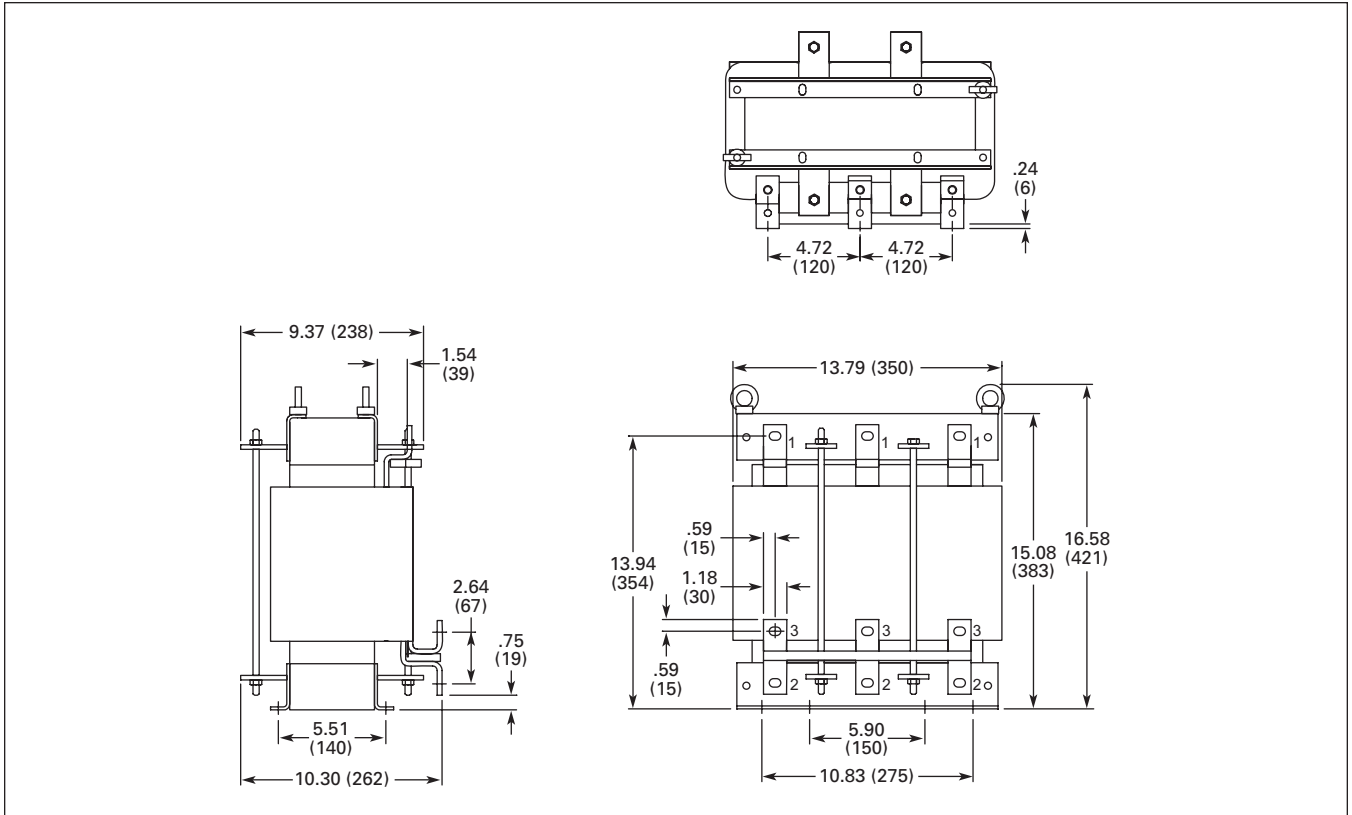

Figure 18. Dimensions of AC Choke CHK0400 in Inches (mm)

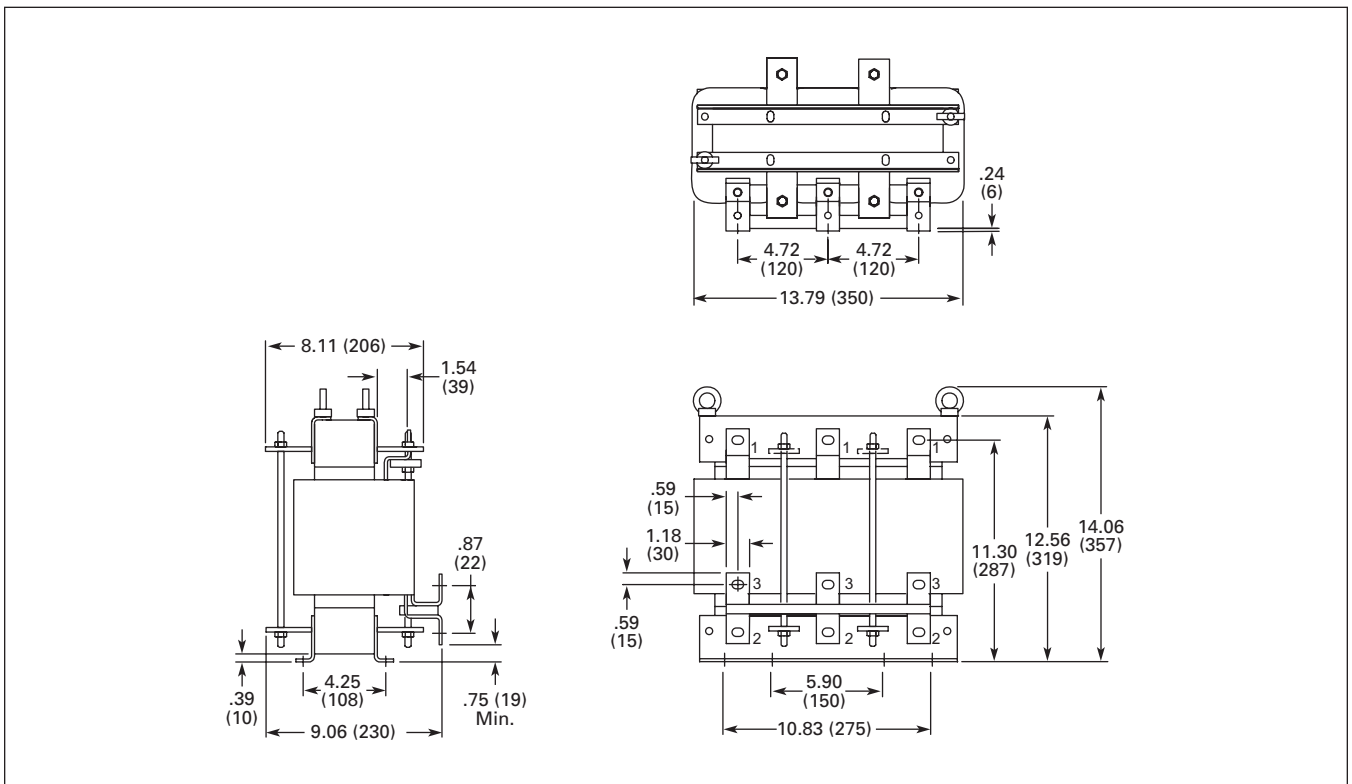

Figure 19. Dimensions of AC Choke CHK0261 in Inches (mm)

Open Drives

Spare Units & Replacement Parts

Table 48. 9000X Spare Units – SVX9000, 208 – 690V, Frames 4 – 12

Description	Catalog Number	Price U.S. \$
Control Unit – Includes the control board, blue base housing, installed SVX9000 software program and blue flip cover. Does not include any OPT boards or keypad. See Figure 1 and Table 17 (Page 11) for standard and option boards and keypad.	CSBS0000000000	

Table 49. 9000X Series Replacement Parts — SVX9000 Drives, 208 – 240V

Frame:	4			5			6			7			8			Delivery Code	Catalog Number	Price U.S. \$		
hp (I _H):	3/4	1	1-1/2	2	3	5 ^①	5	7-1/2	10	15	20	25	30	40	50				60	
Control Board																				
1	1	1					1	1	1	1	1	1	1	1	1	1	1	W	VB00252	
Power Boards																				
1																		FB	VB00308-0004-2	
	1																	FB	VB00308-0007-2	
		1																FB	VB00308-0008-2	
			1															FB	VB00310-0011-2	
				1														FB	VB00310-0012-2	
					1													FB	VB00313-0017-2	
						1												FB	VB00313-0025-2	
							1											FB	VB00313-0031-2	
								1										FB	VB00316-0048-2	
									1									FB	VB00316-0061-2	
										1								FB	VB00319-0075-2	
											1							FB	VB00319-0088-2	
												1						FB	VB00319-0114-2	
													1					FB	VB00322-0140-2	
														1				FB	VB00322-0170-2	
															1			FB	VB00322-0205-2	
Electrolytic Capacitors																				
2	2	2																W	PP01000	
			2	2														W	PP01001	
					2													W	PP01002	
						2												W	PP01003	
							2											W	PP01004	
								2	2									W	PP01005	
										2	2	2	4	4				W	PP01005	
															4			W	PP01099	
Cooling Fans																				
1	1	1		1	1													W	PP01060	
					1		1	1										W	PP01061	
									1	1								W	PP01062	
											1	1	1					W	PP01063	
														1	1	1		FC	PP01123 ^②	
1	1	1		1	1													W	PP01086	
					1		1	1										FC	PP01088	
											1	1	1					W	PP01049	
														1	2	2		FC	CP01180	
														1	1	1		FC	PP08037	

① I_L only; has no corresponding I_H rated hp rating.
 ② PP00061 capacitor not included in main fan; please order separately.

June 2006

Open Drives

Table 49. 9000X Series Replacement Parts — SVX9000 Drives, 208 – 240V (Continued)

Frame:	4				5				6				7				8				Delivery Code	Catalog Number	Price U.S. \$
hp (I _H):	3/4	1	1-1/2	2	3	5 ^①	5	7-1/2	10	15	20	25	30	40	50	60							
IGBT Modules																							
1	1																			W	CP01304		
		1																		W	CP01305		
			1	1	1															W	CP01306		
						1														W	CP01307		
							1													W	CP01308		
								1												W	PP01022		
									1											W	PP01023		
										1										W	PP01024		
											1									W	PP01025		
												1								W	PP01029		
													1							W	PP01026		
														1	1					W	PP01027		
Choppers/Rectifiers																							
									1											W	CP01367		
										1										W	CP01368		
Diode/Thyristor Modules																							
											3	3	3							W	PP01035		
														3	3	3				W	CP01268		
Rectifying Boards																							
										1	1	1								W	VB00242		
														1	1	1				W	VB00227		

① I_L only; has no corresponding I_H rated hp rating.

Table 50. 9000X Series Replacement Parts — FR4 – FR9 SVX9000 Drives, 380 – 500V

Frame:	4						5				6				7				8				9				Delivery Code	Catalog Number	Price U.S. \$		
hp (I _H):	1	1-1/2	2	3	5	7-1/2 ^②	7-1/2	10	15	20	25	30	40	50	60	75	100	125	150	200											
Control Board																															
1	1	1	1	1	1	1	1	1	1	1	1	1	1	1	1	1	1	1	1	1	1	1	1	1	1	1	1	1	W	VB00252	
Power Boards																															
1																													FB	VB00208-0003-5	
	1																												FB	VB00208-0004-5	
		1																											FB	VB00208-0005-5	
			1																										FB	VB00208-0007-5	
				1																									FB	VB00208-0009-5	
					1																								FB	VB00210-0012-5	
						1																							FB	VB00213-0016-5	
							1																						FB	VB00213-0022-5	
								1																					FB	VB00213-0031-5	
									1																				FB	VB00216-0038-5	
										1																			FB	VB00216-0045-5	
											1																		FB	VB00216-0061-5	
												1																	FB	VB00219-0072-5	
													1																FB	VB00219-0087-5	
														1															FB	VB00219-0105-5	
															1														FB	VB00236-0140-5	
																1													FB	VB00236-0168-5	
																	1												FB	VB00236-0205-5	
Electrolytic Capacitors																															
2	2		2	2																									W	PP01000	
				2	2																								W	PP01001	
						2	2																						W	PP01002	
								2																					W	PP01003	
									2	2	2																		W	PP01004	
												2	2	2	4	4	4	8	8										W	PP01005	

② I_L only; has no corresponding I_H rated hp rating.

Open Drives

Table 50. 9000X Series Replacement Parts — FR4 – FR9 SVX9000 Drives, 380 – 500V (Continued)

Frame:	4						5			6			7			8			9		Delivery Code	Catalog Number	Price U.S. \$	
hp (I _H):	1	1-1/2	2	3	5	7-1/2 ①	7-1/2	10	15	20	25	30	40	50	60	75	100	125	150	200				
Cooling Fans																								
	1	1		1	1	1																W	PP01060	
							1		1	1												W	PP01061	
											1	1	1									W	PP01062	
													1	1	1							W	PP01063	
																1	1	1				FC	PP01123 ②	
																			1	1		FC	PP01080 ③	
	1	1		1	1	1	1															W	PP01086	
							1		1	1												FC	PP01088	
										1	1	1	1	1	1							W	PP01049	
																1	1	1				FC	CP01180	
																			1 ④	2		W	PP01068	
																			1	1		FC	PP09051	
IGBT Modules																								
	1	1		1																		W	CP01304	
				1	1																	W	CP01305	
					1			1														W	CP01306	
									1													W	CP01307	
										1												W	CP01308	
											1											W	PP01020	
												1										W	PP01022	
													1									W	PP01023	
														1								W	PP01024	
															1							W	PP01025	
																1						W	PP01029	
																	1					W	PP01026	
																	1	1				W	PP01027	
Chopper/Rectifiers																								
										1	1											W	CP01367	
												1										W	CP01368	
Diode/Thyristor Modules																								
														3	3	3						W	PP01035	
																	3	3	3			W	CP01268	
																			3	3		W	PP01037	
Rectifying Boards																								
													1	1	1							W	VB00242	
																1	1	1				W	VB00227	
																			1	1		W	VB00459	
Rectifying Module Sub-assembly																								
																			1	1		W	FR09810	
Power Module Sub-assemblies																								
																				1		W	FR09-150-4-ANS ⑤	
																					1	W	FR09-200-4-ANS ⑤	

① I_L only; has no corresponding I_H rated hp rating.
 ② PP00061 capacitor not included in main fan; please order separately.
 ③ PP00011 capacitor not included in main fan; please order separately.
 ④ For FR9 NEMA Type 12 you need two PP01068 internal fans.
 ⑤ See Table 54 for details.

June 2006

Open Drives

Table 51. 9000X Series Replacement Parts — FR10 – FR12 SVX9000 Drives, 380 – 500V

Frame:	10			11			12			Delivery Code	Catalog Number	Price U.S. \$
hp (I _H):	250	300	350	400	500	550	600	650	700			
Control Board												
1	1	1	1	1	1	1	1	1	1	W	VB00561 ①	
Shunt Boards												
6										FC	VB00537	
	6									FC	VB00497	
		6					12	12	12	FC	VB00498	
			9							FC	VB00538	
				9						FC	VB00513	
					9					FC	VB00514	
Driver Boards												
			3	3	3					FC	VB00489	
1	1	1					2	2	2	FC	VB00487	
Driver Adapter Board												
1	1	1					2	2	2	FC	VB00330	
ASIC Board												
1	1	1	1	1	1	1	2	2	2	FC	VB00451	
Feedback Interface Board												
							2	2	2	FC	VB00448	
Star Coupler Board												
							1	1	1	FC	VB00336	
Power Modules												
1	1	1	2	2	2	2	2	2	2	FC	FR10820 ②	
2	2	2								FC	FR10828	
1										FC	FR10-250-4-ANS ③	
	1									FC	FR10-300-4-ANS ③	
		1					2	2	2	FC	FR10-350-4-ANS ③	
			3							FC	FR11-400-4-ANS ③	
				3						FC	FR11-500-4-ANS ③	
					3					FC	FR11-550-4-ANS ③	
Electrolytic Capacitors												
2	2	2	3	3	3	4	4	4	4	FC	PP00060	
12	12	12	18	18	18	24	24	24	24	FC	PP01005	
Fuses												
1	1	1	1	1	1	2	2	2	2	FC	PP01094	
2	2	2	2	2	2	4	4	4	4	FC	PP01095	
Cooling Fans and Isolation Transformers												
2	2	2	3	3	3	4	4	4	4	FC	VB00299	
2	2	2	3	3	3	4	4	4	4	FC	PP01080 ④	
2	2	2				4	4	4	4	FC	PP01068	
1	1	1	1	1	1	2	2	2	2	FC	PP01096	
1	1	1				2	2	2	2	FC	FR10844	
1	1	1	3	3	3	2	2	2	2	FC	FR10845	
1	1	1				2	2	2	2	FC	FR10846	
1	1	1	3	3	3	2	2	2	2	FC	FR10847	
Rectifying Board												
1	1	1	2	2	2	2	2	2	2	FC	VB00459	

- ① SPX9000 Drives only (FR10 and larger).
- ② Rectifying board not included.
- ③ See Table 54 for details.
- ④ PP00060 capacitor not included in main fan; please order separately.

Discount Symbol..... SS-2

Open Drives

Table 52. 9000X Series Replacement Parts — FR6 – FR9 SVX9000 Drives, 525 – 690V

Frame:	6								7		8		9				Delivery Code	Catalog Number	Price U.S. \$		
hp (I _H):	2	3	5 ①	5	7-1/2	10	15	20	25	30	40	50	60	75	100	125				150	200 ①
Control Board																					
	1	1	1	1	1	1	1	1	1	1	1					1	1	1	W	VB00252	
Driver Board																					
	1																		FB	VB00404-0004-6	
		1																	FB	VB00404-0005-6	
			1																FB	VB00404-0007-6	
				1															FB	VB00404-0010-6	
					1														FB	VB00404-0013-6	
						1													FB	VB00404-0018-6	
							1												FB	VB00404-0022-6	
								1											FB	VB00404-0027-6	
									1										FB	VB00404-0034-6	
Power Boards																					
										1									FB	VB00419-0041-6	
											1								FB	VB00419-0052-6	
												1							FB	VB00422-0062-6	
													1						FB	VB00422-0080-6	
														1					FB	VB00422-0100-6	
Power Modules																					
															1				FC	FR09-100-5-ANS ②	
																1			FC	FR09-125-5-ANS ②	
																	1		FC	FR09-150-5-ANS ②	
																		1	FC	FR09-175-5-ANS ②	
Electrolytic Capacitors																					
	2	2	2	2	2	2	2	2	2										FC	PP01093	
										2	2	4	4		8	8	8	8	FC	PP01041	
													4						FC	PP01040	
Fuses																					
												1	1	1	1	1	1	1	W	PP01094	
												2	2	2	2	2	2	2	W	PP01095	
Cooling Fans																					
	1	1	1	1	1														W	PP01061	
						1	1	1	1										W	PP01062	
										1	1								W	PP01063	
											1	1	1						FC	PP01123	
	1	1	1	1	1	1	1	1	1	1	1								W	PP01049	
												1	1	1					FC	CP01180	
															1	1	1	1	W	PP01068	
															1	1	1	1	FC	PP01080	
Fan Power Supply																					
																1	1	1	FC	VB00299	
IGBT Modules																					
	3	3	3	3	3	3	3	3	3										FC	PP01091	
										1	1								FC	PP01089	
												1	1	1					FC	PP01127	
IGBT/Diode (Brake)																					
	1	1	1	1	1	1	1	1	1	1	1	2	2	2	2	2	2	2	FC	PP01040	
Diode Module																					
	1	1	1	1	1	1	1	1	1										FC	PP01092	
Diode/Thyristor Modules																					
										3	3								FC	PP01071	
															3	3	3	3	FC	PP01072	
Rectifying Boards																					
										1	1								FC	VB00442	
															1	1	1	1	FC	VB00460	
Rectifying Module Sub-assemblies																					
																1	1	1	W	FR09810	
																1	1	1	FC	FR09811	

① I_L only; has no corresponding I_H rated hp rating.
 ② See Table 54 for details.
 ③ For NEMA Type 12, two PP01068 internal fans are needed.

June 2006

Open Drives

Table 53. 9000X Series Replacement Parts — FR10 – FR12 SVX9000 Drives, 525 – 690V

Frame:	10			11			12			Delivery Code	Catalog Number	Price U.S. \$
hp (I _H):	200	250	300	400	450	500	550	600	700			
Component Boards												
1	1	1	1	1	1	1	1	1	1	W	VB00561 ①	
1	1	1	1	1	1	1	2	2	2	FC	VB00451	
6										FC	VB00545	
	6									FC	VB00510	
		6					12	12	12	FC	VB00511	
1	1	1					2	2	2	FC	VB00330	
1	1	1					2	2	2	FC	VB00487	
			3	3	3					FC	VB00489	
			9							FC	VB00546	
				9						FC	VB00547	
					9					FC	VB00512	
						2	2	2	2	FC	VB00448	
						1	1	1	1	FC	VB00336	
Power Modules												
1	1	1	2	2	2	2	2	2	2	FC	FR10821 ②	
2	2	2								FC	FR10829	
1										FC	FR10-200-5-ANS ③	
	1									FC	FR10-250-5-ANS ③	
		1					2	2	2	FC	FR10-300-5-ANS ③	
			3							FC	FR11-400-5-ANS ③	
				3						FC	FR11-450-5-ANS ③	
					3					FC	FR11-500-5-ANS ③	
Electrolytic Capacitors												
2	2	2	3	3	3	4	4	4	4	FC	PP00060	
12	12	12	18	18	18	24	24	24	24	FC	PP01099	
Fuses												
1	1	1	1	1	1	2	2	2	2	FC	PP01094	
2	2	2	2	2	2	4	4	4	4	FC	PP01095	
Cooling Fans and Isolation Transformers												
2	2	2	3	3	3	4	4	4	4	FC	VB00299	
2	2	2	3	3	3	4	4	4	4	FC	PP01080 ④	
2	2	2				4	4	4	4	FC	PP01068	
1	1	1	1	1	1	2	2	2	2	FC	PP01096	
1	1	1				2	2	2	2	FC	FR10844	
1	1	1	3	3	3	2	2	2	2	FC	FR10845	
1	1	1				2	2	2	2	FC	FR10846	
1	1	1	3	3	3	2	2	2	2	FC	FR10847	
Fan Power Supply												
						1	1	1	1	FC	VB00299	
Rectifying Boards												
1	1	1	2	2	2	2	2	2	2	FC	VB00460	

- ① SPX9000 Drives only (FR10 and larger).
- ② Rectifying board not included.
- ③ See Table 54 for details.
- ④ PP00060 capacitor not included in main fan; please order separately.

Table 54. Power Module Catalog Number Matrix

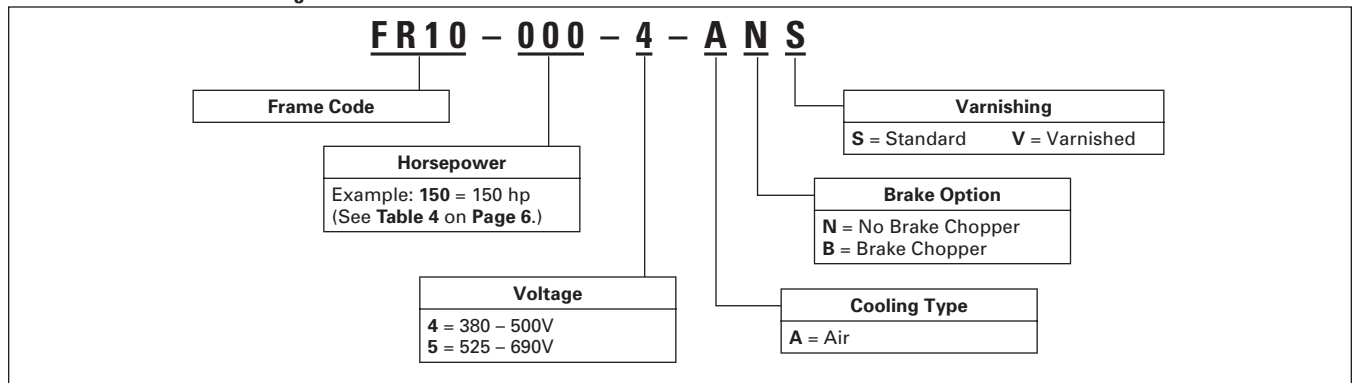

Discount Symbol..... SS-2

Enclosed Drives

SVX9000 Enclosed Drives

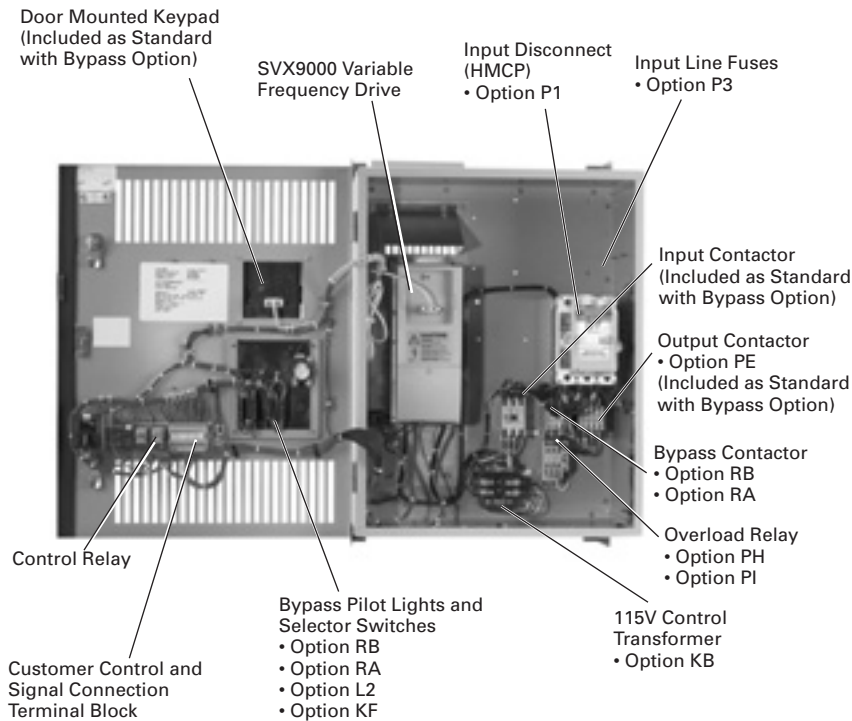

Enclosed 9000X Series Drive

Standards and Certifications

- UL Listed
- cUL Listed

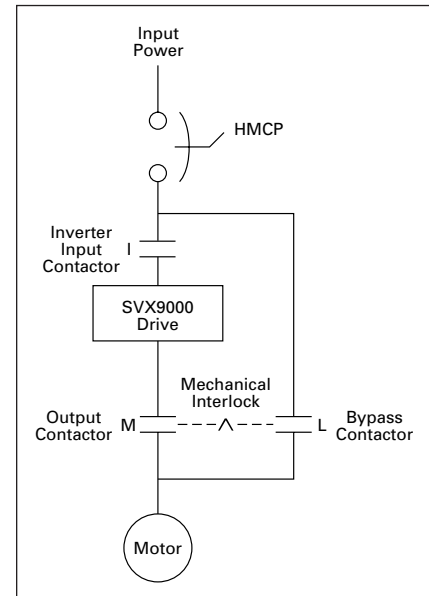

Figure 20. Power Diagram for Bypass Options RB and RA

Product Description

- **Standard Enclosed** — covers a wide range of the most commonly ordered options. Pre-engineering eliminates the lead time normally associated with customer specific options.
- **Modified Standard Enclosed** — applies to specific customer requirements that vary from the Standard Enclosed offering, such as the need for an additional indicating light or minor modifications to drawings. *Consult your Eaton representative for assistance in pricing and lead time.*
- **Custom Engineered** — for those applications with more unique or complex requirements, these are individually engineered to the customer's needs. *Consult your Eaton representative for assistance in pricing and lead time.*

Features

- NEMA Type 1 or Type 12 enclosures
- Input Voltage: 208V, 230V, 480V and 575V (Consult Factory)
- Complete range of control, network and power options
- Horsepower range:
 - 208V — 3/4 to 100 hp I_H; 1 to 100 hp I_L
 - 230V — 3/4 to 100 hp I_H; 1 to 100 hp I_L
 - 480V — 1 to 700 hp I_H; 1-1/2 to 800 hp I_L
- HMCP padlockable

June 2006

Enclosed Drives

Technical Data and Specifications

Table 55. Specifications

Feature Description	9000X Enclosed Products — NEMA Type 1 or NEMA Type 12
Primary Design Features	
45 – 66 Hz Input Frequency	Standard
Output: AC Volts Maximum	Input Voltage Base
Output Frequency Range: Hz	0 – 320
Initial Output Current (I _H)	250% for 2 seconds
Overload: 1 Minute (I _H /I _L)	150%/110%
Enclosure Space Heater	Optional
Oversize Enclosure	Standard
Output Contactor	Optional
Bypass Motor Starter	Optional
Listings	UL, cUL
Protection Features	
Incoming Line Fuses	Optional
AC Input Circuit Disconnect	Optional
Line Reactors	Standard
Phase Rotation Insensitive	Standard
EMI Filter	Standard
Input Phase Loss Protection	Standard
Input Overvoltage Protection	Standard
Line Surge Protection	Standard
Output Short Circuit Protection	Standard
Output Ground Fault Protection	Standard
Output Phase Protection	Standard
Overtemperature Protection	Standard
DC Overvoltage Protection	Standard
Drive Overload Protection	Standard
Motor Overload Protection	Standard
Programmer Software	Optional
Local/Remote Keypad	Standard
Keypad Lockout	Standard
Fault Alarm Output	Standard
Built-In Diagnostics	Standard
Input/Output Interface Features	
Setup Adjustment Provisions: Remote Keypad/Display Personal Computer	Standard Standard
Operator Control Provisions: Drive Mounted Keypad/Display Remote Keypad/Display Conventional Control Elements Serial Communications 115V AC Control Circuit	Standard Standard Standard Optional Optional
Speed Setting Inputs: Keypad 0 – 10V DC Potentiometer/Voltage Signal 4 – 20 mA Isolated 4 – 20 mA Differential 3 – 15 psig	Standard Standard Configurable Configurable Optional
Analog Outputs: Speed/Frequency Torque/Load/Current Motor Voltage Kilowatts 0 – 10V DC Signals 4 – 20 mA DC Signals Isolated Signals	Standard Programmable Programmable Programmable Configurable w/Jumpers Standard Optional

Feature Description	9000X Enclosed Products — NEMA Type 1 or NEMA Type 12
---------------------	--

Input/Output Interface Features (Continued)

Discrete Outputs: Fault Alarm Drive Running Drive at Set Speed Optional Parameters Dry Contacts Open Collector Outputs Additional Discrete Outputs	Standard Standard Programmable 14 1 (2 Relays Form C) 1 Optional
Communications: RS-232 RS-422/485 DeviceNet™ Modbus RTU CanOpen (Slave) Profibus-DP Lonworks® Johnson Controls Metasys™ N2	Standard Optional Optional Optional Optional Optional Optional Optional

Performance Features

Sensorless Vector Control	Standard
Volts/Hertz Control	Standard
IR and Slip Compensation	Standard
Electronic Reversing	Standard
Dynamic Braking	Optional ①
DC Braking	Standard
PID Setpoint Controller	Programmable
Critical Speed Lockout	Standard
Current (Torque) Limit	Standard
Adjustable Acceleration/Deceleration	Standard
Linear or S Curve Accel/Decel	Standard
Jog at Preset Speed	Standard
Thread/Preset Speeds	7
Automatic Restart	Selectable
Coasting Motor Start	Standard
Coast or Ramp Stop Selection	Standard
Elapsed Time Meter	Optional
Carrier Frequency Adjustment	1 – 16 kHz

Standard Conditions for Application and Service

Operating Ambient Temperature	0 – 40°C
Storage Temperature	-40 – 60°C
Humidity (Maximum), Non-condensing	95%
Altitude (Maximum without Derate)	3300 ft. (1000m)
Line Voltage Variation	+10/-15%
Line Frequency Variation	45 – 66 Hz
Efficiency	>96%
Power Factor (Displacement)	>.94

① Some horsepower units include dynamic braking chopper as standard — refer to individual drive sections.

Table 56. Standard I/O Specifications

Description	Specification
6 – Digital Input Programmable	24V: "0" ≤ 10V, "1" ≥ 18V; R _i > 5 kΩ
2 – Analog Input Configurable w/Jumpers	Voltage: 0 – ±10V, R _i > 200 kΩ Current: 0 (4) – 20 mA, R _i = 250 kΩ
2 – Digital Output Programmable	Form C Relays 250V AC 2 Amp or 30V DC 2 Amp resistive
1 – Digital Output Programmable	Open collector 48V DC 50 mA
1 – Analog Output Programmable Configurable w/Jumper	0 – 20 mA, impedance 500 ohms, resolution 106 ±3%

Enclosed Drives

Catalog Number Selection

Table 57. SVX9000 Enclosed NEMA Type 1/12 Drive Catalog Numbering System

Build Alphabetically and Numerically

SVX F07 1 4 A A

Product Family
SVX = Enclosed Drives

Horsepower Rating		
F07 = 3/4 hp	025 = 25 hp	250 = 250 hp
001 = 1 hp	030 = 30 hp	300 = 300 hp
F15 = 1-1/2 hp	040 = 40 hp	350 = 350 hp
002 = 2 hp	050 = 50 hp	400 = 400 hp
003 = 3 hp	060 = 60 hp	500 = 500 hp
005 = 5 hp	075 = 75 hp	550 = 550 hp
007 = 7-1/2 hp	100 = 100 hp	600 = 600 hp
010 = 10 hp	125 = 125 hp	650 = 650 hp
015 = 15 hp	150 = 150 hp	700 = 700 hp
020 = 20 hp	200 = 200 hp	800 = 800 hp

Enclosure Rating
1 = NEMA Type 1
2 = NEMA Type 12
6 = NEMA 12 Filtered

Voltage Rating
1 = 208V
2 = 230V
4 = 480V

Application — Torque/Braking ②
A = I_L/No Brake Chopper
B = I_L/Internal Brake Chopper
D = I_H/No Brake Chopper
E = I_H/Internal Brake Chopper

Enclosed Style
A = Enclosed Drive

Enclosed Options ①④⑤		Type
K1	Door-Mounted Speed Potentiometer ③	Control
K2	Door-Mounted Speed Potentiometer with HOA Selector Switch ③	Control
K3	3 – 15 psig Follower	Control
K4	HAND/OFF/AUTO Switch (22 mm)	Control
K5	MANUAL/AUTO Ref Switch (22 mm)	Control
K6	START/STOP Pushbuttons (22 mm)	Control
KB	115V Control Transformer – 550 VA	Control
KF	Bypass Test Switch for RA and RB	Addl. Bypass
KO	Standard Elapsed Time Meter	Control
L1	Power On and Fault Pilot Lights	Light
L2	Bypass Pilot Lights for RA, RB Bypass Options	Addl. Bypass
LA	Green RUN Light (22 mm)	Light
LD	Green STOP Light (22 mm)	Light
LE	Red RUN Light	Light
LJ	Red STOP Light (22 mm)	Light
LF	White Power On Light (22 mm)	Light
LU	Misc. Light (22 mm)	Light
P1	Input Disconnect (HMCP) 100 kAIC	Input
P2	Disconnect Switch ⑦	Input
P3	Input Line Fuses (200 kAIC)	Input
P7	Input Power Surge Protection	Input
PE	Output Contactor	Output
PF	Output Filter	Output
PG	MotoRx (Up to 600 Ft.) 1000 V/μS DV/DT Filter	Output
PH	Single Overload Relay	Output
PI	Dual Overload Relays	Output
PN	Dual Overloads for Bypass	Addl. Bypass
RA	Manual HOA Bypass Controller	Bypass
RB	Manual IOB Bypass Controller	Bypass
RC	Auto Transfer HOA Bypass Controller	Bypass
RD	Auto Transfer IOB Bypass Controller	Bypass
S5	Floor Stand 22"	Enclosure
S6	Floor Stand 12"	Enclosure
S7	10" Expansion	Enclosure
S8	20" Expansion	Enclosure
S9	Space Heater	Enclosure

Communication Options ⑥		
C2 = Modbus	C6 = CanOpen (Slave)	CA = Johnson Controls N2
C3 = Profibus DP	C7 = DeviceNet	CI = Modbus TCP
C4 = LonWorks	C8 = Modbus (D9 Connector)	CJ = BACnet
C5 = Profibus DP (D9 Connector)		CK = Ethernet IP
		D3 = RS-232 with D9 Connection

Control Options	
B1 = 6 DI, 1 ext +24V DC/EXT +24V DC	B5 = 3 RO (NO)
B2 = 1 RO (NC/NO), 1 RO (NO), 1 Therm	B8 = 1 ext +24V DC/EXT +24V DC, 3 Pt100
B4 = 1 AI (mA isolated), 2 AO (mA isolated), 1 ext +24V DC/EXT +24V DC	B9 = 1 RO (NO), 5 DI 42 – 240V AC Input

Engineered Options	
HT	High Temperature rating for 50°C (FR10 and above) ⑧
VB	Varnished Boards

① Local/Remote keypad is included as the standard Control Panel.
 ② Brake Chopper is a factory installed option only, see drive option tables on Pages 45 – 53. Note: External dynamic braking resistors not included. Consult factory.
 ③ Includes local/remote speed reference switch.
 ④ Some options are voltage and/or horsepower specific. Consult your Eaton representative for details.
 ⑤ See Pages 41 and 42 for descriptions.
 ⑥ See Pages 43 and 44 for complete descriptions.
 ⑦ Applicable only with FR10 and FR11 Freestanding designs.
 ⑧ Consult Eaton for pricing and availability.

June 2006

Enclosed Drives

Control/Communication Option Descriptions

Table 58. Available Control/Communications Options

Option	Description	Option Type
K1	Door-Mounted Speed Potentiometer — Provides the SVX9000 with the ability to adjust the frequency reference using a door-mounted potentiometer. This option uses the 10V DC reference to generate a 0 – 10V signal at the analog voltage input signal terminal. When the HOA bypass option is added, the speed is controlled when the HOA switch is in the hand position. Without the HOA bypass option, a 2-position switch (labeled local/remote) is provided on the keypad to select speed reference from the Speed Potentiometer or a remote speed signal.	Control
K2	Door-Mounted Speed Potentiometer with HOA Selector Switch — Provides the SVX9000 with the ability to start/stop and adjust the speed reference from door-mounted control devices or remotely from customer supplied inputs. In HAND position, the drive will start and the speed is controlled by the door-mounted speed potentiometer. The drive will be disabled in the OFF position. When AUTO is selected, the drive run and speed control commands are via user-supplied dry contact and 4 – 20 mA signal.	Control
K3	3 – 15 psig Follower — Provides a pneumatic transducer which converts a 3 – 15 psig pneumatic signal to either 0 – 8V DC or a 1 – 9V DC signal interface with the SVX9000. The circuit board is mounted on the inside of the front enclosure panel and connects to the user's pneumatic control system via 6 ft. (1.8m) of flexible tubing and a 1/4 inch (6.4 mm) brass tube union.	Control
K4	HAND/OFF/AUTO Switch for Non-bypass Configurations — Provides a three-position selector switch that allows the user to select either a Hand or Auto mode of operation. Hand mode is defaulted to keypad operation, and Auto mode is defaulted to control from an external terminal source. These modes of operation can be configured via programming to allow for alternate combinations of start and speed sources. Start and speed sources include Keypad, I/O and FieldBus.	Control
K5	MANUAL/AUTO Speed Reference Switch — Provides a door-mounted selector switch for Manual/Auto speed reference.	Control
K6	START/STOP Pushbuttons — Provides door-mounted START and STOP pushbuttons for either bypass or non-bypass configurations.	Control
KB	115V Control Transformer – 550 VA — Provides a fused control power transformer with additional 550 VA at 115V for customer use.	Control
KF	Bypass Test Switch for RB and RA — Allows the user to energize the AF drive for testing while operating the motor on the bypass controller. The Test Switch is mounted on the inside of the enclosure door.	Addl. Bypass
KO	Standard Elapsed Time Meter — Provides a door-mounted elapsed run time meter.	Control
L1	Power On and Fault Pilot Lights — Provides a white power on light that indicates power to the enclosed cabinet and a red fault light indicates a drive fault has occurred.	Light
L2	Bypass Pilot Lights for RB, RA Bypass Options — A green light indicates when the motor is running in inverter mode and an amber light indicates when the motor is running in bypass mode. The lights are mounted on the enclosure door, above the switches.	Addl. Bypass
LA	Green RUN Light (22 mm) — Provides a green run light that indicates the drive is running.	Light
LD	Green STOP Light (22 mm) — Provides a green stop light that indicates the drive is stopped.	Light
LE	Red Run Pilot Light (22 mm) — Provides a red run pilot light that indicates the drive is running.	Light
LF	Red STOP Light (22 mm) — Provides a red stop light that indicates the drive is stopped.	Light
LJ	White Power On Light (22 mm) — The 22 mm white light that illuminates when the drive assembly is powered.	Light
LU	Misc. Light (22 mm) — Provides a misc. "user defined" pilot light. User to define light function and color.	Light
P1	Input Disconnect Assembly Rated to 100 kAIC — High Interrupting Motor Circuit Protector (HMCP) that provides a means of short circuit protection for the power cables between it and the SVX9000, and protection from high-level ground faults on the power cable. Allows a convenient means of disconnecting the SVX9000 from the line and the operating mechanism can be padlocked in the OFF position. This is factory mounted in the enclosure.	Input
P2	Disconnect Switch — Disconnect switch option is applicable only with NEMA Type 1 and NEMA Type 12 Freestanding drives. Allows a convenient means of disconnecting the SVX9000 from the line, and the operating mechanism can be padlocked in the OFF position. This is factory-mounted in the enclosure.	Input
P3	Input Line Fuses Rated to 200 kAIC — Provides high-level fault protection of the SVX9000 input power circuit from the load side of the fuses to the input side of the power transistors. This option consists of three 200 kA fuses, which are factory mounted in the enclosure.	Input
P7	MOV Surge Suppressor — Provides a Metal Oxide Varistor (MOV) connected to the line side terminals and is designed to clip line side transients.	Input
PE	Output Contactor — Provides a means for positive disconnection of the drive output from the motor terminals. The contactor coil is controlled by the drive's run or permissive logic. NC and NO auxiliary contacts rated at 10A, 600V AC are provided for customer use. Bypass Options RB and RA include an Output Contactor as standard. This option includes a low VA 115V AC fused Control Power Transformer and is factory mounted in the enclosure.	Output
PF	Output Filter — Used to reduce the transient voltage (DV/DT) at the motor terminals. The Output Filter is recommended for cable lengths exceeding 100 ft. (30m) with a drive of 3 hp and above, for cable lengths of 33 ft. (10m) with a drive of 2 hp and below, or for a drive rated at 525 – 690V. This option is mounted in the enclosure, and may be used in conjunction with a Brake Chopper Circuit.	Output
PG	MotoRx (300 – 600 Ft.) 1000 V/μS DV/DT Filter — Used to reduce transient voltage (DV/DT) and peak voltages at the motor terminals. This option is comprised of a .5% line reactor, followed by capacitive filtering and an energy recovery/clamping circuit. Unlike the Output Filter (See option PF), the MotoRx recovers most of the energy from the voltage peaks, resulting in a lower voltage drop to the motor, and therefore conserving power. This option is used when the distance between a single motor and the drive is 300 – 600 feet (91 – 183m). <i>This option can not be used with the Brake Chopper Circuit. The Output Filter (option PF) should be investigated as an alternative.</i>	Output
PH	Single Overload Relay — Uses a bimetallic overload relay to provide additional overload current protection to the motor on configurations without bypass options. It is included with the Bypass Configurations for overload current protection in the bypass mode. The Overload Relay is mounted within the enclosure, and is manually resettable. Heater pack included.	Output

Enclosed Drives

Table 58. Available Control/Communications Options (Continued)

Option	Description	Option Type
PI	Dual Overload Relays — This option is recommended when a single drive is operating 2 motors and overload current protection is needed for each of the motors. The standard configuration includes two bimetallic overload relays, each sized to protect a motor with 50% of the drive hp rating. For example, a 100 hp drive would include two overload relays sized to protect two 50 hp motors. The relays are mounted within the enclosure, and are manually resettable. Heater packs not included.	Output
PN	Dual Overloads for Bypass — This option is recommended when a single drive is operating 2 motors in the bypass mode and overload current protection is needed for each of the motors. The standard configuration includes two bimetallic overload relays, each sized to protect a motor with 50% of the drive hp rating. For example, a 100 hp drive would include two overload relays sized to protect two 50 hp motors. The relays are mounted within the enclosure, and are manually resettable.	Addl. Bypass
RA	Manual HOA Bypass Controller — The Manual HAND/OFF/AUTO (HOA) — 3-contactor — bypass option provides a means of bypassing the SVX9000, allowing the AC motor to be operated at full speed directly from the AC supply line. This option consists of an input disconnect, a fused control power transformer, and a full voltage bypass starter with a door mounted HOA selector switch and an INVERTER/BYPASS switch. The HOA switch provides the ability to start and stop the drive in the inverter mode. For applications up to 100 hp, a Freedom Series IEC input contactor, a Freedom Series IEC output contactor, and a Freedom Series IEC starter with a bimetallic overload relay is included. For applications above 100 hp, an Advantage input contactor, an Advantage output contactor and an Advantage starter with electronic overload protection is included. The contactors are mechanically and electrically interlocked (see power diagram on Page 38).	Bypass
RB	Manual IOB Bypass Controller — The Manual INVERTER/OFF/BYPASS (IOB) — 3-contactor — bypass option provides a means of bypassing the SVX9000, allowing the AC motor to be operated at full speed directly from the AC supply line. This option consists of an input disconnect, a fused control power transformer, and a full voltage bypass starter with a door mounted IOB selector switch. For applications up to 100 hp, a Freedom Series IEC input contactor, a Freedom Series IEC output contactor, and a Freedom Series IEC starter with a bimetallic overload relay is included. For applications above 100 hp, an Advantage input contactor, an Advantage output contactor and an Advantage starter with electronic overload protection is included. The contactors are mechanically and electrically interlocked (see power diagram on Page 38).	Bypass
RC	Auto Transfer HOA Bypass Controller — The Manual HAND/OFF/AUTO (HOA) — 3-contactor — bypass option provides a means of bypassing the SVX9000, allowing the AC motor to be operated at full speed directly from the AC supply line. The circuitry provides an automatic transfer of the load to “across the line” operation after a drive trip. This option consists of an input disconnect, a fused control power transformer, and a full voltage bypass starter with a door mounted HOA selector switch and an INVERTER/BYPASS switch. The HOA switch provides the ability to start and stop the drive in either mode. For applications up to 100 hp, a Freedom Series IEC input contactor, a Freedom Series IEC output contactor, and a Freedom Series IEC starter with a bimetallic overload relay is included. For applications above 100 hp, an Advantage input contactor, an Advantage output contactor and an Advantage starter with electronic overload protection is included. The contactors are mechanically and electrically interlocked (see power diagram on Page 38). Door-mounted pilot lights are provided which indicate bypass or inverter operation. A green light indicates when the motor is running in inverter mode and an amber light indicates when the motor is running in bypass mode. WARNING: The motor may restart when the overcurrent relay is reset when operating in bypass, unless the IOB selector switch is turned to the OFF position.	Bypass
RD	Auto Transfer IOB Bypass Controller — The Auto INVERTER/OFF/BYPASS (IOB) — 3-contactor — bypass option provides a means of bypassing the SVX9000, allowing the AC motor to be operated at full speed directly from the AC supply line. The circuitry provides an automatic transfer of the load to “across the line” operation after a drive trip. This option consists of an input disconnect, a fused control power transformer, and a full voltage bypass starter with a door mounted IOB selector switch. For applications up to 100 hp, a Freedom Series IEC input contactor, a Freedom Series IEC output contactor, and a Freedom Series IEC starter with a bimetallic overload relay is included. For applications above 100 hp, an Advantage input contactor, an Advantage output contactor and an Advantage starter with electronic overload protection is included. The contactors are mechanically and electrically interlocked (see power diagram on Page 38). Door-mounted pilot lights are provided which indicate bypass or inverter operation. A green light indicates when the motor is running in inverter mode and an amber light indicates when the motor is running in bypass mode. WARNING: The motor may restart when the overcurrent relay is reset when operating in bypass, unless the IOB selector switch is turned to the OFF position.	Bypass
S5	Floor Stand 22" — Converts a Size 1 or 2, normally wall mounted enclosure to a floor standing enclosure with a height of 22" (558.8 mm).	Enclosure
S6	Floor Stand 12" — Converts a Size 2, normally wall mounted enclosure to a floor standing enclosure with a height of 12" (304.8 mm).	Enclosure
S7	10" Expansion — In a Size 5 enclosure, the extension allows for bottom cable entry and additional space for customer mounted components. NOTE: Enclosure expansion rated NEMA Type 1 only.	Enclosure
S8	20" Expansion — In a Size 5 enclosure, the extension allows for bottom cable entry and additional space for customer mounted components. When the Output Filter (option PF) is selected for a drive using a Size 5 enclosure, this expansion box is required and included in the option pricing. NOTE: Enclosure expansion rated NEMA Type 1 only.	Enclosure
S9	Space Heater — Prevents condensation from forming in the enclosure when the drive is inactive or in storage. Includes a thermostat for variable temperature control. A 200W heater is installed in enclosures 0 and 1, and a 400W heater is installed in enclosures 2 – 5. Requires a customer supplied 115V remote supply source.	Enclosure

Note: For availability, see Product Selection for base drive voltage required.

June 2006

Enclosed Drives

9000X Series Option Board Kits

The 9000X Series drives can accommodate a wide selection of expander and adapter option boards to customize the drive for your application needs. The drive's control unit is designed to accept a total of five option boards (see Figure 21).

The 9000X Series factory installed standard board configuration includes an A9 I/O board and an A2 relay output board, which are installed in slots A and B.

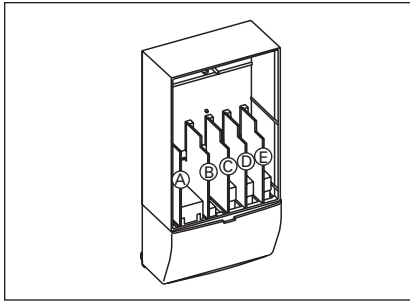

Figure 21. 9000X Series Option Boards

Table 59. Option Board Kits

Option Kit Description ②	Allowed Slot Locations ①	Field Installed		Factory Installed		SVX Ready Programs						
		Catalog Number	Price U.S. \$	Option Designator	Adder U.S. \$	Basic	Local/Remote	Standard	MSS	PID	Multi-P.	PFC
Standard I/O Cards (See Figure 21)												
2 RO (NC/NO)	B	OPTA2		—		X	X	X	X	X	X	X
6 DI, 1 DO, 2 AI, 1AO, 1 +10V DC ref, 2 ext +24V DC/ EXT +24V DC	A	OPTA9		—		X	X	X	X	X	X	X
Extended I/O Card Options												
2 RO, Therm — SPX Only	B	OPTA3		A3		—	X	X	X	X	X	X
Encoder low volt +5V/15V/24V — SPX Only	C	OPTA4		A4		—	X	X	X	X	X	X
Encoder high volt +15V/24V — SPX Only	C	OPTA5		A5		—	X	X	X	X	X	X
Double encoder — SPX Only	C	OPTA7		A7		X	X	X	X	X	X	X
6 DI, 1 DO, 2 AI, 1 AO — SPX Only	A	OPTA8		A8		—	X	X	X	X	X	X
3 DI (Encoder 10 – 24V), Out +15V/+24V, 2 DO (pulse+direction) — SPX Only	C	OPTAE		AE		X	X	X	X	X	X	X
6 DI, 1 ext +24V DC/EXT +24V DC	B, C, D, E	OPTB1		B1		—	—	—	—	—	X	X
1 RO (NC/NO), 1 RO (NO), 1 Therm	B, C, D, E	OPTB2		B2		—	—	—	—	—	X	X
1 AI (mA isolated), 2 AO (mA isolated), 1 ext +24V DC/EXT +24V DC	B, C, D, E	OPTB4		B4		X	X	X	X	X	X	X
3 RO (NO)	B, C, D, E	OPTB5		B5		—	—	—	—	—	X	X
1 ext +24V DC/EXT +24V DC, 3 Pt100	B, C, D, E	OPTB8		B8		—	—	—	—	—	—	—
1 RO (NO), 5 DI 42 – 240V AC Input	B,C, D, E	OPTB9		B9		—	—	—	—	—	X	X
Communication Cards ③												
Modbus	D, E	OPTC2		C2		X	X	X	X	X	X	X
Modbus TCP	D, E	OPTCI		CI		X	X	X	X	X	X	X
BACnet	D, E	OPTCJ		CJ		X	X	X	X	X	X	X
Ethernet IP	D, E	OPTCK		CK		X	X	X	X	X	X	X
Johnson Controls N2	D, E	OPTC2		CA		—	—	—	—	—	—	—
Profibus DP	D, E	OPTC3		C3		X	X	X	X	X	X	X
LonWorks	D, E	OPTC4		C4		X	X	X	X	X	X	X
Profibus DP (D9 Connector)	D, E	OPTC5		C5		X	X	X	X	X	X	X
CanOpen (Slave)	D, E	OPTC6		C6		X	X	X	X	X	X	X
DeviceNet	D, E	OPTC7		C7		X	X	X	X	X	X	X
Modbus (D9 Type Connector)	D, E	OPTC8		C8		X	X	X	X	X	X	X
Adapter — SPX Only	D, E	OPTD1		D1		X	X	X	X	X	X	X
Adapter — SPX Only	D, E	OPTD2		D2		X	X	X	X	X	X	X
RS-232 with D9 Connection	D, E	OPTD3		D3		X	X	X	X	X	X	X
Keypad												
9000X Series Local Remote Keypad	—	KEYPAD-LOC/REM		—		—	—	—	—	—	—	—
9000X Series Remote Mount Keypad Kit (Keypad not included)	—	OPTRMT-KIT-9000X		—		—	—	—	—	—	—	—
9000X Series RS-232 Cable, 13 ft.	—	PP00104		—		—	—	—	—	—	—	—

① Option card must be installed in one of the slots listed for that card. Slot indicated in Bold is the preferred location.

② AI = Analog Input; AO = Analog Output, DI = Digital Input, DO = Digital Output, RO = Relay Output

③ OPTC2 is a multi-protocol option card.

Discount Symbol..... **SS-2**

Enclosed Drives

Modbus RTU Network Communications

The Modbus Network Card OPTC2 is used for connecting the 9000X Drive as a slave on a Modbus network. The interface is connected by a 9-pin DSUB connector (female) and the baud rate ranges from 300 to 19200 baud. Other communication parameters include an address range from 1 to 247; a parity of None, Odd or Even; and the stop bit is 1.

Profibus Network Communications

The Profibus Network Card OPTC3 is used for connecting the 9000X Drive as a slave on a Profibus-DP network. The interface is connected by a 9-pin DSUB connector (female). The baud rates range from 9.6K baud to 12M baud, and the addresses range from 1 to 127.

LonWorks Network Communications

The LonWorks Network Card OPTC4 is used for connecting the 9000X Drive on a LonWorks network. This interface uses Standard Network Variable Types (SNVT) as data types. The channel connection is achieved using a FTT-10A Free Topology transceiver via a single twisted transfer cable. The communication speed with LonWorks is 78 kBits/s.

CanOpen (Slave) Communications

The CanOpen (Slave) Network Card OPTC6 is used for connecting the 9000X Drive to a host system. According to ISO11898 standard cables to be chosen for CAN bus should have a nominal impedance of 120Ω, and specific line delay of nominal 5 nS/m. 120Ω line termination resistors required for installation.

DeviceNet Network Communications

The DeviceNet Network Card OPTC7 is used for connecting the 9000X Drive on a DeviceNet Network. It includes a 5.08 mm pluggable connector. Transfer method is via CAN using a 2-wire twisted shielded cable with 2-wire bus power cable and drain. The baud rates used for communication include 125K baud, 250K baud and 500K baud.

Johnson Controls Metasys™ N2 Network Communications

The OPTC2 fieldbus board provides communication between the 9000X Drive and a Johnson Controls Metasys™ N2 network. With this connection, the drive can be controlled, monitored and programmed from the Metasys system. The N2 fieldbus is available as a factory installed option and as a field installable kit.

Modbus/TCP Network Communications

The Modbus/TCP Network Card OPTCI is used for connecting the 9000X Drive to Ethernet networks utilizing Modbus

protocol. It includes an RJ-45 pluggable connector. This interface provides a selection of standard and custom register values to communicate drive parameters. The board supports 10 Mbps and 100 Mbps communication speeds. The IP address of the board is configurable over Ethernet using a supplied software tool.

BACnet Network Communications

The BACnet Network Card OPTCJ is used for connecting the 9000X Drive to BACnet networks. It includes a 5.08 mm pluggable connector. Data transfer is Master-Slave/Token Passing (MS/TP) RS-485. This interface uses a collection of 30 Binary Value Objects (BVOs) and 35 Analog Value Objects (AVOs) to communicate drive

parameters. The card supports 9.6, 19.2 and 38.4 Kbaud communication speeds and supports network addresses 1 – 127.

Ethernet/IP Network Communications

The Ethernet/IP Network Card OPTCK is used for connecting the 9000X Drive to Ethernet/Industrial Protocol networks. It includes an RJ-45 pluggable connector. The interface uses CIP objects to communicate drive parameters (CIP is “Common Industrial Protocol”, the same protocol used by DeviceNet). The board supports 10 Mbps and 100 Mbps communication speeds. The IP address of the board is configurable by Static, BOOTP and DHCP methods.

Table 60. I/O Specifications for the Control/Communication Options

Description	Specifications
Analog voltage, input	0 – ±10V, R _i ≥ 200 kΩ
Analog current, input	0 (4) – 20 mA, R _i = 250 Ω
Digital Input	24V: “0” ≤ 10V, “1” ≥ 18V, R _i > 5 kΩ
Aux. voltage	24V (±20%), max. 50 mA
Reference voltage	10V ±3%, max. 10 mA
Analog current, output	0 (4) – 20 mA, R _L = 500 kΩ, resolution 10 bit, accuracy ≤ ±2%
Analog voltage, output	0 (2) – 10V, R _L ≥ 1 kΩ, resolution 10 bit, accuracy ≤ ±2%
Relay output	
Max. switching voltage	300V DC, 250V AC
Max. switching load	8A/24V DC, .4A/300V DC, 2 kVA/250V AC
Max. continuous load	2A rms
Thermistor input	R _{trip} = 4.7 kΩ
Encoder input	24V: “0” ≤ 10V, “1” ≥ 18V, R _i = 2.2 kΩ 5V: “0” ≤ 2V, “1” ≥ 3V, R _i = 330 Ω

SVX Conversion Kit

Table 61. SVX Conversion Kit Frame 4 – 7

Frame Size	Enclosure Size	Catalog Number	Delivery Code	Price U.S. \$
FR4	0	OPTCON-SVXFR4-SZ00	FB10	
FR4	1	OPTCON-SVXFR4-SZ01	FB10	
FR5	0	OPTCON-SVXFR5-SZ00	FB10	
FR5	1	OPTCON-SVXFR5-SZ01	FB10	
FR6	1	OPTCON-SVXFR6-SZ01	FB10	
FR6	2	OPTCON-SVXFR6-SZ02	FB10	
FR7	2	OPTCON-SVXFR7-SZ02	FB10	

Note: The kit consists of a flange kit, adapter plate(s), hardware, remote keypad kit and SVX9000 decal.

Table 62. Conformal (Varnished) Coating Adder — 208 – 240V, 380 – 500V ①

Frame	Delivery Code	Adder U.S. \$
FR4	FP	
FR5	FP	
FR6	FP	
FR7	FP	
FR8	FP	
FR9	FP	
FR10	FP	
FR11	FP	
FR12	FP	
FR13	FP	
FR14	FP	

① See catalog number description to order.

Discount Symbol..... **SS-2**

June 2006

Enclosed Drives

Product Selection

When Ordering

- Select a Base Catalog Number that meets the application requirements — nominal horsepower, voltage and enclosure rating (the enclosed drive's continuous output amp rating should be equal to or greater than the motor's full load amp rating). The base enclosed package includes a standard drive, door mounted Local/Remote Keypad and enclosure.
- If Dynamic Brake Chopper or Control/Communication option is desired, change the appropriate code in the Base Catalog Number.
- Select Enclosed Options. Add the codes as suffixes to the Base Catalog Number in alphabetical and numeric order.
- Read all Footnotes.

208V Drives

Table 63. 208V AC Input Base Drive

Enclosure Size ①	hp	Current (A)	NEMA Type 1			NEMA Type 12		
			Frame Size	Base Catalog Number ②	Price U.S. \$ ②	Frame Size	Base Catalog Number ②	Price U.S. \$ ②
208V High Overload Drive and Enclosure								
0	3/4	3.7	4	SVXF0711EA		4	SVXF0721EA	
0	1	4.8	4	SVX00111EA		4	SVX00121EA	
0	1-1/2	6.6	4	SVXF1511EA		4	SVXF1521EA	
0	2	7.8	4	SVX00211EA		4	SVX00221EA	
0	3	11	4	SVX00311EA		4	SVX00321EA	
0	5	17.5	5	SVX00511EA		5	SVX00521EA	
0	7-1/2	25	5	SVX00711EA		5	SVX00721EA	
1	10	31	6	SVX01011EA		6	SVX01021EA	
1	15	48	6	SVX01511EA		6	SVX01521EA	
2	20	61	7	SVX02011DA		7	SVX02021DA	
2	25	75	7	SVX02511DA		7	SVX02521DA	
2	30	88	7	SVX03011DA		7	SVX03021DA	
3	40	114	8	SVX04011DA		8	SVX04021DA	
4	50	143	8	SVX05011DA		8	SVX05021DA	
5	60	170	8	SVX06011DA		8	SVX06021DA	
5	75	211	9	SVX07511DA		9	SVX07521DA	
5	100	273	9	SVX10011DA		9	SVX10021DA	

208V Low Overload Drive and Enclosure

0	1	4.8	4	SVX00111BA		4	SVX00121BA	
0	1-1/2	6.6	4	SVXF1511BA		4	SVXF1521BA	
0	2	7.8	4	SVX00211BA		4	SVX00221BA	
0	3	11	4	SVX00311BA		4	SVX00321BA	
0	5	17.5	5	SVX00511BA		5	SVX00521BA	
0	7-1/2	25	5	SVX00711BA		5	SVX00721BA	
0	10	31	5	SVX01011BA		5	SVX01021BA	
1	15	48	6	SVX01511BA		6	SVX01521BA	
1	20	61	6	SVX02011BA		6	SVX02021BA	
2	25	75	7	SVX02511AA		7	SVX02521AA	
2	30	88	7	SVX03011AA		7	SVX03021AA	
2	40	114	7	SVX04011AA		7	SVX04021AA	
3	50	—	8	SVX05011AA		8	SVX05021AA	
4	60	170	8	SVX06011AA		8	SVX06021AA	
5	③	205 ③	8	SVX07511AA		8	SVX07521AA	
5	③	261 ③	9	SVX10011AA		9	SVX10021AA	

① Enclosure dimensions listed on Pages 54 – 61.

② Includes drive, Local/Remote Keypad and enclosure.

③ These units are current rated (75 I_L hp 205 Amps, 100 I_L hp 261 Amps). They are not hp rated.

Table 64. 208V Brake Chopper Adder ④

I _H hp	Adder U.S. \$	I _L hp	Adder U.S. \$
	NEMA Type 1/12		NEMA Type 1/12
3/4		—	
1		1	
1-1/2		1-1/2	
2		2	
3		3	
5		5	
7-1/2		7-1/2	
10		10	
15		15	
20		20	
25		25	
30		30	
40		40	
50		50	
60		60	
75		75	
100		100	

④ External dynamic braking resistors not included. Consult factory.

Discount Symbol..... SS-3

Enclosed Drives

Table 65. 208V Control Options

Catalog Number Suffix 	Door-Mounted Speed Potentiometer	Door-Mounted Speed Potentiometer with HOA Selector Switch	3 – 15 psig Follower	HAND/OFF/AUTO Switch (22 mm)	MANUAL/AUTO Ref Switch (22 mm)	START/STOP Pushbuttons (22 mm)	115 Volt Control Transformer 550 VA	Standard Elapsed Time Meter
	K1	K2	K3	K4	K5	K6	KB	KO
hp	Adder U.S. \$	Adder U.S. \$	Adder U.S. \$	Adder U.S. \$	Adder U.S. \$	Adder U.S. \$	Adder U.S. \$	Adder U.S. \$
3/4 – 100								

Table 66. 208V Light Options



Catalog Number Suffix 	Power On/Fault Pilot Lights (22 mm)	Green RUN Light (22 mm)	Green STOP Light (22 mm)	Red RUN Light (22 mm)	Red STOP Light (22 mm)	Power On Light (22 mm)	Misc Light (22 mm)
	L1	LA	LD	LE	LF	LJ	LU
hp	Adder U.S. \$	Adder U.S. \$	Adder U.S. \$	Adder U.S. \$	Adder U.S. \$	Adder U.S. \$	Adder U.S. \$
3/4 – 100							

Table 67. 208V Bypass Options

Catalog Number Suffix 	Bypass Test Switch for RA, RB	Bypass Pilot Lights for RA, RB Options	Dual Overloads for Bypass	Manual HOA Bypass Controller	Manual IOB Bypass Controller	Auto Transfer HOA Bypass Controller	Auto Transfer IOB Bypass Controller
	KF	L2	PN	RA	RB	RC	RD
hp	Adder U.S. \$	Adder U.S. \$	Adder U.S. \$	Adder U.S. \$	Adder U.S. \$	Adder U.S. \$	Adder U.S. \$
3/4 – 7-1/2							
10							
15							
20							
25							
30							
40							
50							
60							
75							
100							

June 2006

Enclosed Drives

Table 68. 208V Enclosure Options

Catalog Number Suffix →	Floor Stand 22" (558.8 mm)	Floor Stand 12" (304.8 mm)	10" (254 mm) Expansion	20" (508 mm) Expansion	Space Heater ^①
	S5	S6	S7	S8	S9
Enclosure Size	Adder U.S. \$	Adder U.S. \$	Adder U.S. \$	Adder U.S. \$	Adder U.S. \$
0					
1					
2					
3					
4					
5					

^① Requires customer supplied 115V AC supply.

Table 69. 208V Power Options

Catalog Number Suffix →	Input			Output				
	Input Disconnect (HMCP) 100 kAIC	Input Line Fuses 200 kAIC	Input Power Surge Protection	Output Contactor	Output Filter ^②	MotoRx (300– 600 Ft.) 1000 V/μS DV/DT Filter ^②	Single Overload Relay	Dual Overload Relays
	P1	P3	P7	PE	PF	PG	PH	PI
hp	Adder U.S. \$	Adder U.S. \$	Adder U.S. \$	Adder U.S. \$	Adder U.S. \$	Adder U.S. \$	Adder U.S. \$	Adder U.S. \$
3/4–5								
7-1/2								
10								
15								
20								
25								
30								
40								
50								
60								
75								
100								

^② Not required for 208V applications.

Discount Symbol..... **SS-3**

Enclosed Drives

230V Drives

Table 70. 230V AC Input Base Drive

Enclosure Size ①	hp	Current (A)	NEMA Type 1			NEMA Type 12		
			Frame Size	Base Catalog Number ②	Price U.S. \$ ②	Frame Size	Base Catalog Number ②	Price U.S. \$ ②
230V High Overload Drive and Enclosure								
0	3/4	3.7	4	SVXF0712EA		4	SVXF0722EA	
0	1	4.8	4	SVX00112EA		4	SVX00122EA	
0	1-1/2	6.6	4	SVXF1512EA		4	SVXF1522EA	
0	2	7.8	4	SVX00212EA		4	SVX00222EA	
0	3	11	4	SVX00312EA		4	SVX00322EA	
0	5	17.5	5	SVX00512EA		5	SVX00522EA	
0	7-1/2	25	5	SVX00712EA		5	SVX00722EA	
1	10	31	6	SVX01012EA		6	SVX01022EA	
1	15	48	6	SVX01512EA		6	SVX01522EA	
2	20	61	7	SVX02012DA		7	SVX02022DA	
2	25	75	7	SVX02512DA		7	SVX02522DA	
2	30	88	7	SVX03012DA		7	SVX03022DA	
3	40	114	8	SVX04012DA		8	SVX04022DA	
4	50	140	8	SVX05012DA		8	SVX05022DA	
5	60	170	8	SVX06012DA		8	SVX06022DA	
5	75	205	9	SVX07512DA		9	SVX07522DA	
5	100	261	9	SVX10012DA		9	SVX10022DA	
230V Low Overload Drive and Enclosure								
0	1	4.8	4	SVX00112BA		4	SVX00122BA	
0	1-1/2	6.6	4	SVXF1512BA		4	SVXF1522BA	
0	2	7.8	4	SVX00212BA		4	SVX00222BA	
0	3	11	4	SVX00312BA		4	SVX00322BA	
0	5	17.5	5	SVX00512BA		5	SVX00522BA	
0	7-1/2	25	5	SVX00712BA		5	SVX00722BA	
0	10	31	5	SVX01012BA		5	SVX01022BA	
1	15	48	6	SVX01512BA		6	SVX01522BA	
1	20	61	6	SVX02012BA		6	SVX02022BA	
2	25	75	7	SVX02512AA		7	SVX02522AA	
2	30	88	7	SVX03012AA		7	SVX03022AA	
2	40	114	7	SVX04012AA		7	SVX04022AA	
3	50	140	8	SVX05012AA		8	SVX05022AA	
4	60	170	8	SVX06012AA		8	SVX06022AA	
5	75	205	8	SVX07512AA		8	SVX07522AA	
5	③	261 ③	9	SVX10012AA		9	SVX10022AA	

230V Low Overload Drive and Enclosure

0	1	4.8	4	SVX00112BA		4	SVX00122BA	
0	1-1/2	6.6	4	SVXF1512BA		4	SVXF1522BA	
0	2	7.8	4	SVX00212BA		4	SVX00222BA	
0	3	11	4	SVX00312BA		4	SVX00322BA	
0	5	17.5	5	SVX00512BA		5	SVX00522BA	
0	7-1/2	25	5	SVX00712BA		5	SVX00722BA	
0	10	31	5	SVX01012BA		5	SVX01022BA	
1	15	48	6	SVX01512BA		6	SVX01522BA	
1	20	61	6	SVX02012BA		6	SVX02022BA	
2	25	75	7	SVX02512AA		7	SVX02522AA	
2	30	88	7	SVX03012AA		7	SVX03022AA	
2	40	114	7	SVX04012AA		7	SVX04022AA	
3	50	140	8	SVX05012AA		8	SVX05022AA	
4	60	170	8	SVX06012AA		8	SVX06022AA	
5	75	205	8	SVX07512AA		8	SVX07522AA	
5	③	261 ③	9	SVX10012AA		9	SVX10022AA	

① Enclosure dimensions listed on Pages 54 – 61.

② Includes drive, Local/Remote Keypad and enclosure.

③ This unit is current rated (100 I_L hp 261 Amps). It is not hp rated.

Table 71. 230V Brake Chopper Adder ④

I _H hp	Adder U.S. \$	I _L hp	Adder U.S. \$
	NEMA Type 1/12		NEMA Type 1/12
3/4		—	
1		1	
1-1/2		1-1/2	
2		2	
3		3	
5		5	
7-1/2		7-1/2	
10		10	
15		15	
20		20	
25		25	
30		30	
40		40	
50		50	
60		60	
75		75	
100		100	

④ External dynamic braking resistors not included. Consult factory.

June 2006

Enclosed Drives

Table 72. 230V Control Options

Catalog Number Suffix 	Door-Mounted Speed Potentiometer	Door-Mounted Speed Potentiometer with HOA Selector Switch	3 – 15 psig Follower	HAND/OFF/AUTO Switch (22 mm)	MANUAL/AUTO Ref Switch (22 mm)	START/STOP Pushbuttons (22 mm)	115 Volt Control Transformer 550 VA	Standard Elapsed Time Meter
	K1	K2	K3	K4	K5	K6	KB	KO
hp	Adder U.S. \$	Adder U.S. \$	Adder U.S. \$	Adder U.S. \$	Adder U.S. \$	Adder U.S. \$	Adder U.S. \$	Adder U.S. \$
3/4 – 100								

Table 73. 230V Light Options



Catalog Number Suffix 	Power On/Fault Pilot Lights (22 mm)	Green RUN Light (22 mm)	Green STOP Light (22 mm)	Red RUN Light (22 mm)	Red STOP Light (22 mm)	Power On Light (22 mm)	Misc Light (22 mm)
	L1	LA	LD	LE	LF	LJ	LU
hp	Adder U.S. \$	Adder U.S. \$	Adder U.S. \$	Adder U.S. \$	Adder U.S. \$	Adder U.S. \$	Adder U.S. \$
3/4 – 100							

Table 74. 230V Bypass Options ^①

Catalog Number Suffix 	Bypass Test Switch for RA, RB, RC, RD	Bypass Pilot Lights for RA, RB Options	Dual Overloads for Bypass	Manual HOA Bypass Controller	Manual IOB Bypass Controller	Auto Transfer HOA Bypass Controller	Auto Transfer IOB Bypass Controller
	KF	L2	PN	RA	RB	RC	RD
hp	Adder U.S. \$	Adder U.S. \$	Adder U.S. \$	Adder U.S. \$	Adder U.S. \$	Adder U.S. \$	Adder U.S. \$
3/4 – 10							
15							
20							
25							
30							
40							
50							
60							
75							
100							

^① See Pages 41 and 42 for details.

Enclosed Drives

Table 75. 230V Enclosure Options

Catalog Number Suffix 	Floor Stand 22" (558.8 mm)	Floor Stand 12" (304.8 mm)	10" (254 mm) Expansion	20" (508 mm) Expansion	Space Heater ^①
	S5	S6	S7	S8	S9
Enclosure Size	Adder U.S. \$	Adder U.S. \$	Adder U.S. \$	Adder U.S. \$	Adder U.S. \$
0					
1					
2					
3					
4					
5					

^① Requires customer supplied 115V AC supply.

Table 76. 230V Power Options

Catalog Number Suffix 	Input			Output				
	Input Disconnect (HMCP) 100 kAIC	Input Line Fuses 200 kAIC	Input Power Surge Protection	Output Contactor	Output Filter ^②	MotoRx (300 – 600 Ft.) 1000 V/μS DV/DT Filter	Single Overload Relay	Dual Overload Relays
	P1	P3	P7	PE	PF	PG	PH	PI
hp	Adder U.S. \$	Adder U.S. \$	Adder U.S. \$	Adder U.S. \$	Adder U.S. \$	Adder U.S. \$	Adder U.S. \$	Adder U.S. \$
3/4 – 5								
7-1/2								
10								
15								
20								
25								
30								
40								
50								
60								
75								
100								

^② Not required for 230V applications.

Discount Symbol..... SS-3

Enclosed Drives

480V Drives

Table 77. 480V AC Input Base Drive

Enclosure Size ①	hp	Current (A)	NEMA Type 1			NEMA Type 12		
			Frame Size	Base Catalog Number ②	Price U.S. \$ ②	Frame Size	Base Catalog Number ②	Price U.S. \$ ②
High Overload Drive and Enclosure								
0	1	2.2	4	SVX00114EA		4	SVX00124EA	
0	1-1/2	3.3	4	SVXF1514EA		4	SVXF1524EA	
0	2	4.3	4	SVX00214EA		4	SVX00224EA	
0	3	5.6	4	SVX00314EA		4	SVX00324EA	
0	5	7.6	4	SVX00514EA		4	SVX00524EA	
0	7-1/2	12	5	SVX00714EA		5	SVX00724EA	
0	10	16	5	SVX01014EA		5	SVX01024EA	
0	15	23	5	SVX01514EA		5	SVX01524EA	
1	20	31	6	SVX02014EA		6	SVX02024EA	
1	25	38	6	SVX02514EA		6	SVX02524EA	
1	30	46	6	SVX03014EA		6	SVX03024EA	
2	40	61	7	SVX04014DA		7	SVX04024DA	
2	50	72	7	SVX05014DA		7	SVX05024DA	
2	60	87	7	SVX06014DA		7	SVX06024DA	
3	75	105	8	SVX07514DA		8	SVX07524DA	
3	100	140	8	SVX10014DA		8	SVX10024DA	
4	125	170	8	SVX12514DA		8	SVX12524DA	
5	150	205	9	SVX15014DA		9	SVX15024DA	
5	200	245	9	SVX20014DA		9	SVX20024DA	
6, 8 ④⑥	250	300	10	SVX25014DA		10	SVX25064DA	
6, 8 ④⑥	300	385	10	SVX30014DA		10	SVX30064DA	
6, 8 ④⑥	350	460	10	SVX35014DA		10	SVX35064DA	
8, 9 ⑤⑥	400	520	11	SVX40014DA		11	SVX40064DA	
8, 9 ⑤⑥	500	590	11	SVX50014DA		11	SVX50064DA	
8, 9 ⑤⑥	550	650	11	SVX55014DA		11	SVX55064DA	
③	600	730	12	SVX60014DA		12	SVX60064DA	
③	650	820	12	SVX65014DA		12	SVX65064DA	
③	700	920	12	SVX70014DA		12	SVX70064DA	
Low Overload Drive and Enclosure								
0	1-1/2	3.3	4	SVXF1514BA		4	SVXF1524BA	
0	2	4.3	4	SVX00214BA		4	SVX00224BA	
0	3	5.6	4	SVX00314BA		4	SVX00324BA	
0	5	7.6	4	SVX00514BA		4	SVX00524BA	
0	7-1/2	12	4	SVX00714BA		4	SVX00724BA	
0	10	16	5	SVX01014BA		5	SVX01024BA	
0	15	23	5	SVX01514BA		5	SVX01524BA	
0	20	31	5	SVX02014BA		5	SVX02024BA	
1	25	38	6	SVX02514BA		6	SVX02524BA	
1	30	46	6	SVX03014BA		6	SVX03024BA	
1	40	61	6	SVX04014BA		6	SVX04024BA	
2	50	72	7	SVX05014AA		7	SVX05024AA	
2	60	87	7	SVX06014AA		7	SVX06024AA	
2	75	105	7	SVX07514AA		7	SVX07524AA	
3	100	140	8	SVX10014AA		8	SVX10024AA	
4	125	170	8	SVX12514AA		8	SVX12524AA	
4	150	205	8	SVX15014AA		8	SVX15024AA	
5	200	261	9	SVX20014AA		9	SVX20024AA	
5	250	300	9	SVX25014AA		9	SVX25024AA	
6, 8 ④⑥	300	385	10	SVX30014AA		10	SVX30064AA	
6, 8 ④⑥	350	460	10	SVX35014AA		10	SVX35064AA	
6, 8 ④⑥	400	520	10	SVX40014AA		10	SVX40064AA	
8, 9 ⑤⑥	500	590	11	SVX50014AA		11	SVX50064AA	
8, 9 ⑤⑥	550	650	11	SVX55014AA		11	SVX55064AA	
8, 9 ⑤⑥	600	730	11	SVX60014AA		11	SVX60064AA	
③	650	820	12	SVX65014AA		12	SVX65064AA	
③	700	920	12	SVX70014AA		12	SVX70064AA	
③	800	1030	12	SVX80014AA		12	SVX80064AA	

Table 78. 480V Brake Chopper Adder ⑦

I _H hp	Adder U.S. \$	I _L hp	Adder U.S. \$
1		—	
1-1/2		1-1/2	
2		2	
3		3	
5		5	
7-1/2		7-1/2	
10		10	
15		15	
20		20	
25		25	
30		30	
40		40	
50		50	
60		60	
75		75	
100		100	
125		125	
150		150	
200		200	
250		250	
300		300	
350		350	
400		400	
500		500	
550		550	
600		600	
650		650	
700		700	
		800	

⑦ External dynamic braking resistors not included. Consult factory.

- ① Enclosure dimensions listed on Pages 54 – 64.
- ② Includes drive, Local/Remote keypad and enclosure.
- ③ Consult Eaton.
- ④ The smaller Enclosure Size 6 accommodates only power options, Input Disconnect (P1) and Input Line Fuses (P3). Bypass and other options require Size 8. Adding any standard control option will not require the larger enclosure.
- ⑤ The smaller Enclosure Size 8 accommodates only power options, Input Disconnect (P1) and Input Line Fuses (P3). Bypass and other options require Size 9. Adding any standard control option will not require the larger enclosure.
- ⑥ For other options, consult factory.

Enclosed Drives

Table 79. 480V Light Options

Catalog Number Suffix ¹	Power On/Fault Pilot Lights (22 mm)	Green RUN Light (22 mm)	Green STOP Light (22 mm)	Red RUN Light (22 mm)	Red STOP Light (22 mm)	Power On Light (22 mm)	Misc Light (22 mm)
	L1	LA	LD	LE	LF	LJ	LU
hp	Adder U.S. \$	Adder U.S. \$	Adder U.S. \$	Adder U.S. \$	Adder U.S. \$	Adder U.S. \$	Adder U.S. \$
1 - 800							

Table 80. 480V Control Options

Catalog Number Suffix ¹	Door-Mounted Speed Potentiometer	Door-Mounted Speed Potentiometer with HOA Selector Switch	3 - 15 psig Follower	HAND/OFF/AUTO Switch (22 mm)	MANUAL/AUTO Ref Switch (22 mm)	START/STOP Pushbuttons (22 mm)	115 Volt Control Transformer 550 VA	Standard Elapsed Time Meter
	K1	K2	K3	K4	K5	K6	KB	KO
hp	Adder U.S. \$	Adder U.S. \$	Adder U.S. \$	Adder U.S. \$	Adder U.S. \$	Adder U.S. \$	Adder U.S. \$	Adder U.S. \$
1 - 800								

Table 81. 480V Bypass Options ¹

Catalog Number Suffix ¹	Bypass Test Switch for RA, RB, RC, RD	Bypass Pilot Lights for RA, RB Options	Dual Overloads for Bypass	Manual HOA Bypass Controller	Manual IOB Bypass Controller	Auto Transfer HOA Bypass Controller	Auto Transfer IOB Bypass Controller
	KF	L2	PN	RA	RB	RC	RD
hp	Adder U.S. \$	Adder U.S. \$	Adder U.S. \$	Adder U.S. \$	Adder U.S. \$	Adder U.S. \$	Adder U.S. \$
1 - 20							
25							
30							
40							
50							
60							
75							
100							
125							
150							
200							
250							
300							
350							
400							
500							
550							
600							
650							
700							
800							

¹ See Pages 41 and 42 for details.

Table 82. 480V Enclosure Options

Catalog Number Suffix ¹	Floor Stand 22" (558.8 mm)	Floor Stand 12" (304.8 mm)	10" (254 mm) Expansion ³	20" (508 mm) Expansion ⁴	Space Heater ²
	S5	S6	S7	S8	S9
Enclosure Size	Adder U.S. \$	Adder U.S. \$	Adder U.S. \$	Adder U.S. \$	Adder U.S. \$
0					
1					
2					
3					
4					
5					
6					
8					
9					

² Requires customer supplied 115V AC supply.

³ See Enclosure 5-1P on Page 60 for dimensions.

⁴ See Enclosure 5-2P on Page 61 for dimensions.

Discount Symbol SS-3

June 2006

Enclosed Drives

Table 83. 480V Power Options

Catalog Number Suffix	Input			Output				
	Input Disconnect (HMCP) 100 kAIC	Input Line Fuses 200 kAIC	Input Power Surge Protection	Output Contactor	Output Filter ^①	MotoRx (300 – 600 Ft.) 1000 V/μS DV/DT Filter ^①	Single Overload Relay ^②	Dual Overload Relays ^②
	P1	P3	P7	PE	PF	PG	PH	PI
hp	Adder U.S. \$	Adder U.S. \$	Adder U.S. \$	Adder U.S. \$	Adder U.S. \$	Adder U.S. \$	Adder U.S. \$	Adder U.S. \$
1 – 2								
3 – 5								
7-1/2 10 15 20 25								
30 40 50 60 75								
100 125 150 200 250								
300 350 400 500 550								
600 650 700 800								

^① Output filter may be required whenever the distance from the drive to the motor exceeds 100 feet (30m). Refer to Application Notes for further details.

^② Heater packs not included.

Table 84. Input Options

Catalog Number Suffix	Load Switch
hp	Adder U.S. \$
250 300 350	
400 500 550	

^③ Applicable with FR10 and FR11 Freestanding designs only.

Enclosed Drives

Dimensions

Enclosure Size 0

Table 85. Approximate Dimensions and Shipping Weight — Enclosed Products

Enclosure Size	Dimensions in Inches (mm)												
	Wide A	High B	Deep C	Mounting							H	Min. Air Space	
				D	D1	E	E1	F	G	G1		J	K
0	19.9 (504)	29.0 (737)	16.4 (416)	18.3 (465)	—	—	—	27.4 (695)	—	—	25.4 (644)	4.0 (102)	3.0 (76)

Table 85. Approximate Dimensions and Shipping Weight — Enclosed Products (Continued)

Enclosure Size	Dimensions in Inches (mm)											Max. Approx. Ship. Wt. lbs. (kg)
	Cable Entry					Door Clearance S	T	U	V	W		
	L	M	N	P	R							
0	5.0 (127)	—	—	6.0 (152)	9.6 (245)	26.4 (669)	1.5 (38)	6.3 (160)	4.3 (108)	5.3 (134)	200 (91)	

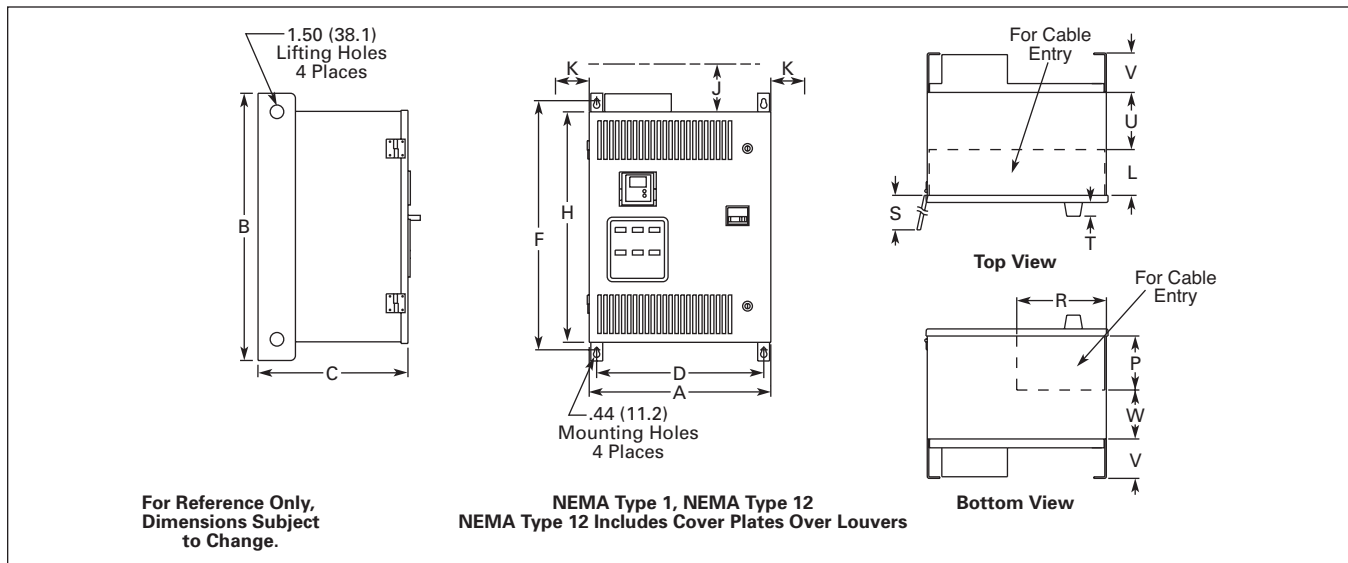

Figure 22. Approximate Dimensions

Enclosed Drives

Enclosure Size 2

Table 87. Approximate Dimensions and Shipping Weight — Enclosed Products

Enclosure Size	Dimensions in Inches (mm)											Min. Air Space	
	Wide A	High B	Deep C	Mounting							H	J	K
				D	D1	E	E1	F	G	G1			
2	26.4 (669)	59.0 (1499)	19.4 (492)	24.8 (630)	—	—	—	57.0 (1448)	—	—	55.4 (1406)	4.0 (102)	3.0 (76)

Table 87. Approximate Dimensions and Shipping Weight — Enclosed Products (Continued)

Enclosure Size	Dimensions in Inches (mm)															
	Cable Entry					Door Clearance S	T	U	V	W	Floor Stand					
	L	M	N	P	R						X	Y	Z	AA	BB	CC
2	5.9 (149)	—	—	12.4 (315)	9.5 (241)	26.4 (669)	1.5 (38)	4.8 (121)	5.9 (151)	—	69.0 (1753)	4.8 (121)	13.6 (344)	1.8 (46)	.8 (19)	68.2 (1732)

Table 87. Approximate Dimensions and Shipping Weight — Enclosed Products (Continued)

Enclosure Size	Dimensions in Inches (mm)															Max. Approx. Ship. Wt. lbs. (kg)	
	Floor Stand											RR	SS	TT	UU		VV
	DD	EE	FF	GG	HH	JJ	KK	LL	MM	NN	PP						
2	26.0 (660)	4.8 (121)	6.8 (172)	3.0 (76)	6.0 (152)	2.0 (51)	5.0 (127)	1.1 (28)	11.3 (288)	79.0 (2007)	78.2 (1986)	—	—	—	—	—	380 (173)

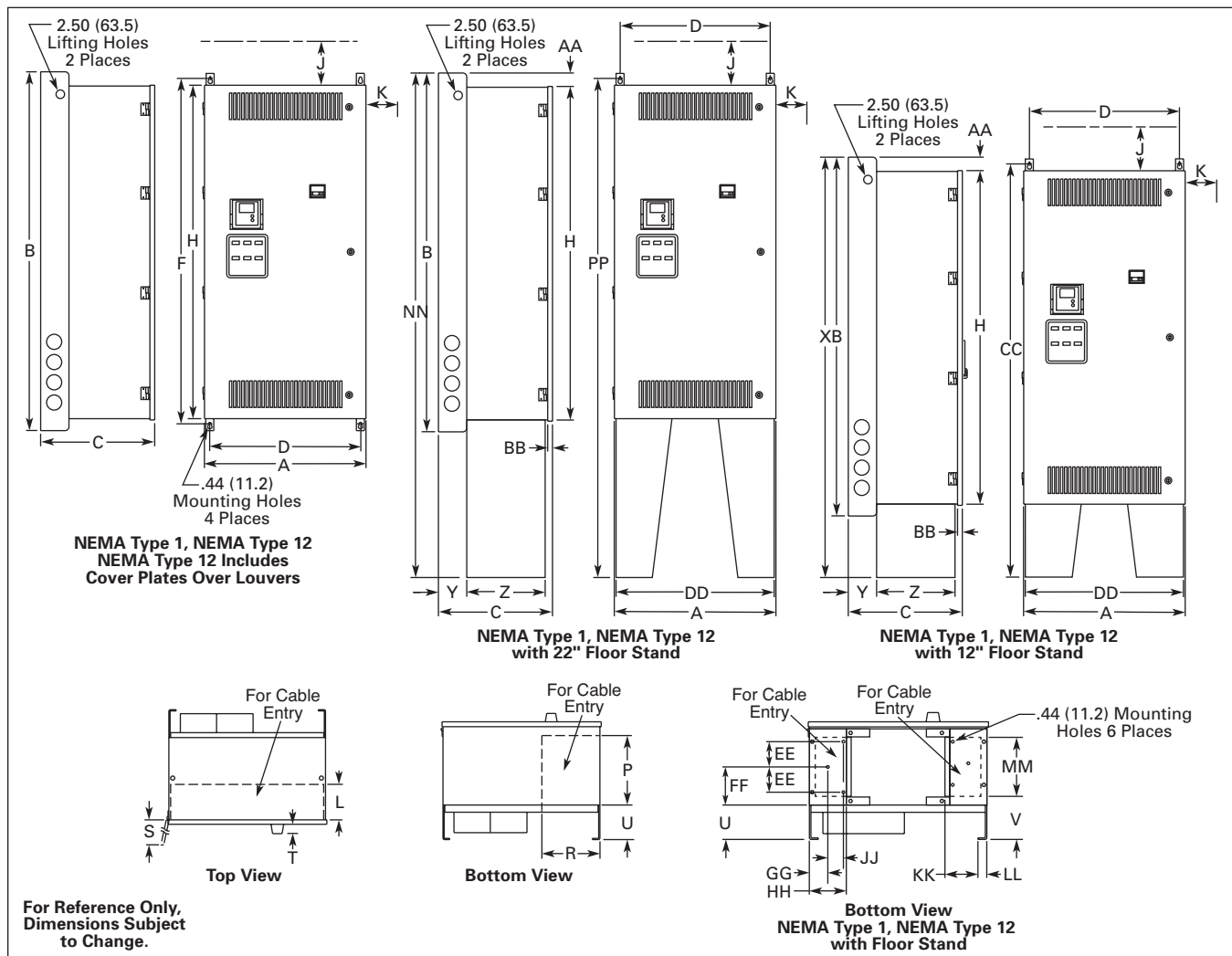

Figure 24. Approximate Dimensions

June 2006

Enclosed Drives

Enclosure Size 3

Table 88. Approximate Dimensions and Shipping Weight — Enclosed Products

Enclosure Size	Dimensions in Inches (mm)			Mounting							H	Min. Air Space	
	Wide A	High B	Deep C	D	D1	E	E1	F	G	G1		J	K
3	26.4 (671)	77.0 (1956)	19.4 (493)	19.5 (495)	3.3 (83)	23.0 (584)	1.5 (38)	11.7 (298)	5.5 (140.)	.9 (24)	76.4 (1939)	4.0 (102)	3.0 (76)

Table 88. Approximate Dimensions and Shipping Weight — Enclosed Products (Continued)

Enclosure Size	Dimensions in Inches (mm)														Max. Approx. Ship. Wt. lbs. (kg)	
	Cable Entry					Door Clearance S	T	U	V	W	RR	SS	TT	UU		VV
L	M	N	P	R												
3	5.3 (133)	23.4 (594)	10.0 (254)	1.3 (32)	12.9 (328)	26.4 (669)	1.5 (38)	8.0 (203)	4.8 (121)	6.8 (173)	79.5 (2018)	13.4 (340)	.8 (19)	1.3 (32)	26.0 (660)	690 (313)

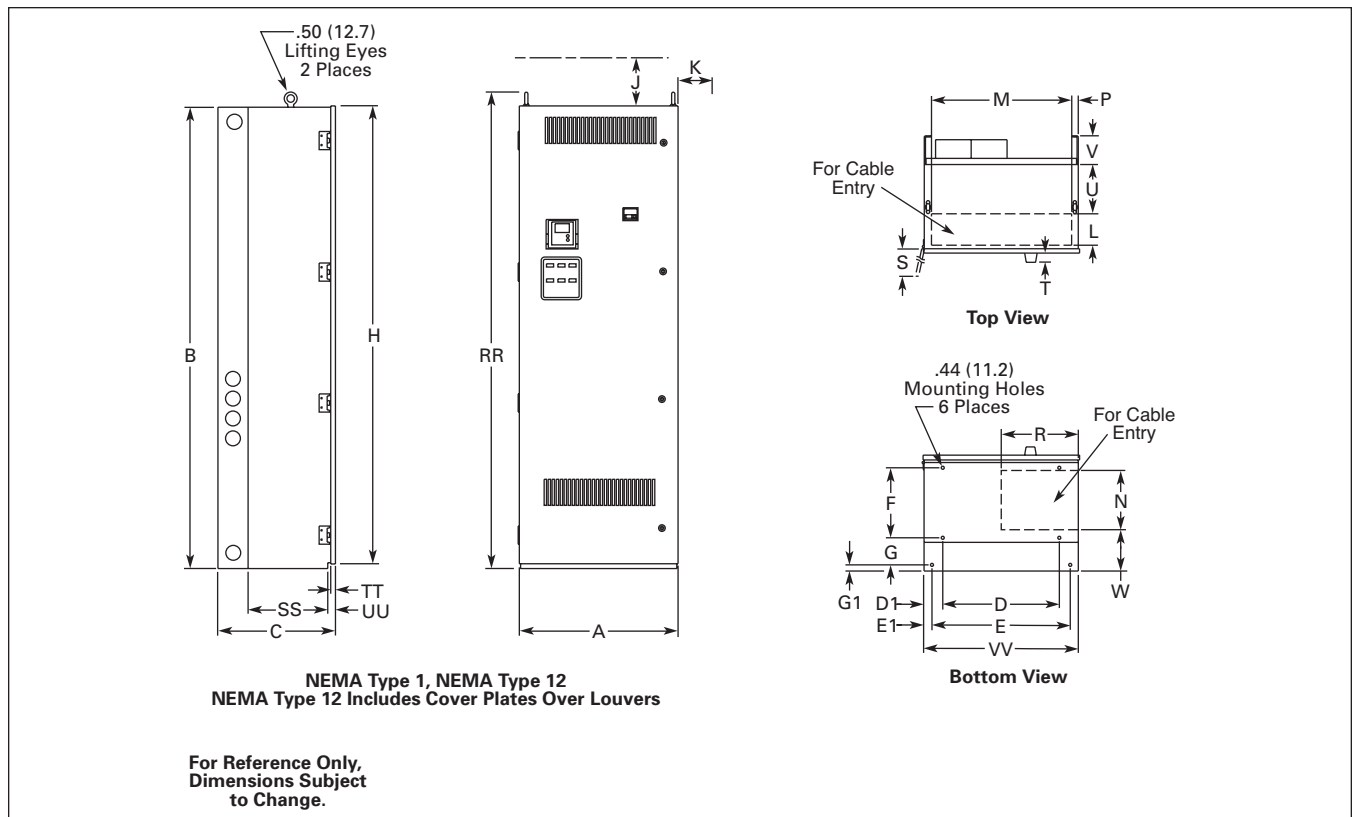

Figure 25. Approximate Dimensions

Enclosed Drives

Enclosure Size 4

Table 89. Approximate Dimensions and Shipping Weight — Enclosed Products

Enclosure Size	Dimensions in Inches (mm)												
	Wide A	High B	Deep C	Mounting							H	Min. Air Space	
				D	D1	E	E1	F	G	G1		J	K
4	26.4 (671)	90.0 (2286)	19.4 (493)	19.5 (495)	3.3 (83)	23.0 (584)	1.5 (38)	11.7 (298)	5.5 (140)	.9 (24)	89.4 (2270)	4.0 (102)	3.0 (76)

Table 89. Approximate Dimensions and Shipping Weight — Enclosed Products (Continued)

Enclosure Size	Dimensions in Inches (mm)														Max. Approx. Ship. Wt. lbs. (kg)	
	Cable Entry					Door Clearance S	T	U	V	W	RR	SS	TT	UU		VV
	L	M	N	P	R											
4	5.3 (133)	23.4 (594)	13.8 (351)	1.0 (25)	11.2 (286)	26.4 (669)	1.5 (38)	8.0 (204)	4.8 (121)	—	92.5 (2349)	.8 (19)	1.3 (32)	—	—	825 (375)

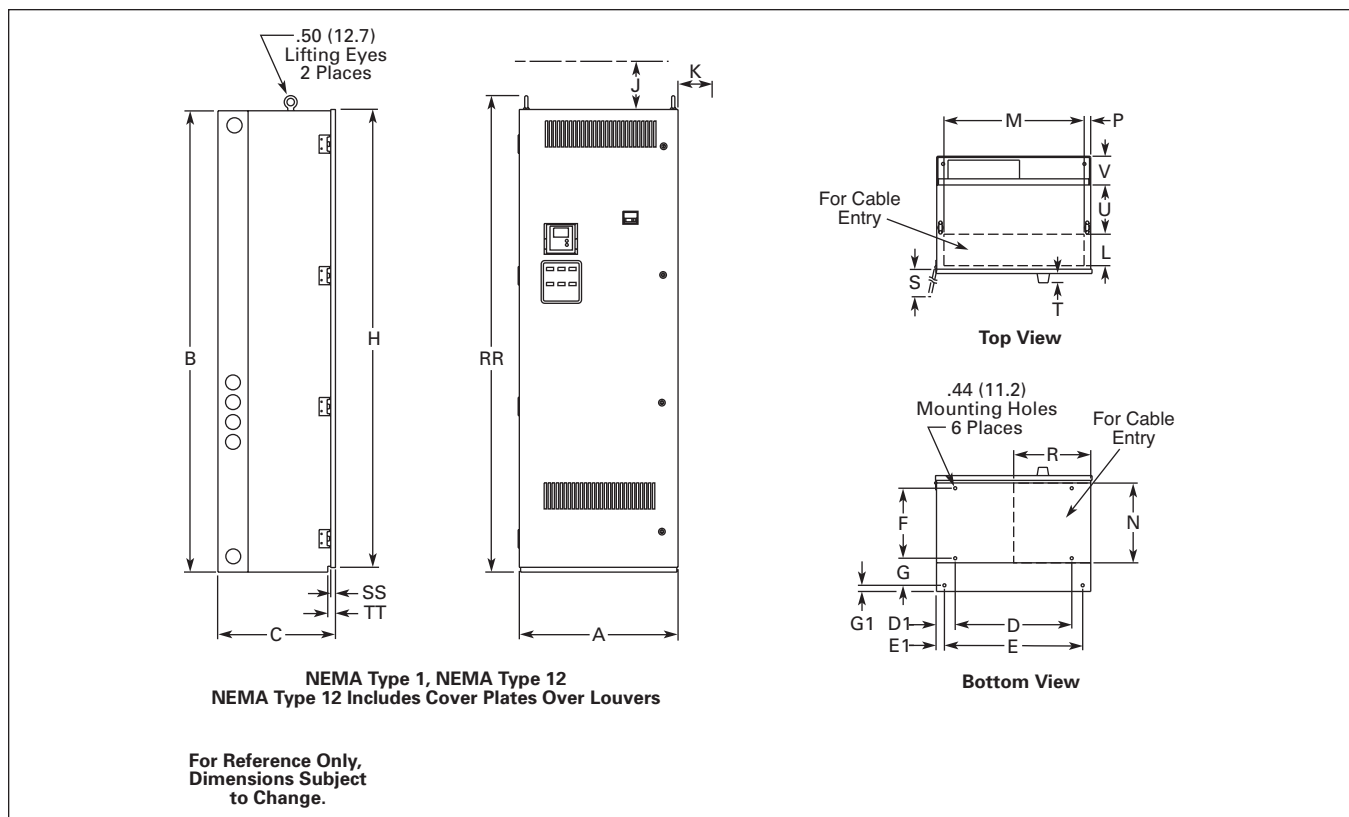

Figure 26. Approximate Dimensions

June 2006

Enclosed Drives

Enclosure Size 5

Table 90. Approximate Dimensions and Shipping Weight — Enclosed Products

Enclosure Size	Dimensions in Inches (mm)											Min. Air Space	
	Wide A	High B	Deep C	Mounting							H	J	K
				D	D1	E	E1	F	G	G1			
5	40.0 (1016)	90.0 (2286)	21.3 (541)	36.0 (914)	2.0 (51)	—	—	8.0 (203)	10.8 (273)	—	84.4 (2143)	4.0 (102)	—

Table 90. Approximate Dimensions and Shipping Weight — Enclosed Products (Continued)

Enclosure Size	Dimensions in Inches (mm)													Max. Approx. Ship. Wt. lbs. (kg)		
	Cable Entry					Door Clearance S	T	U	V	W	RR	SS	TT		UU	VV
	L	M	N	P	R											
5	15.0 (381)	10.0 (254)	4.8 (122)	2.0 (51)	—	36.3 (921)	20.0 (508)	—	—	—	94.0 (2387)	15.5 (394)	—	—	—	1275 (579)

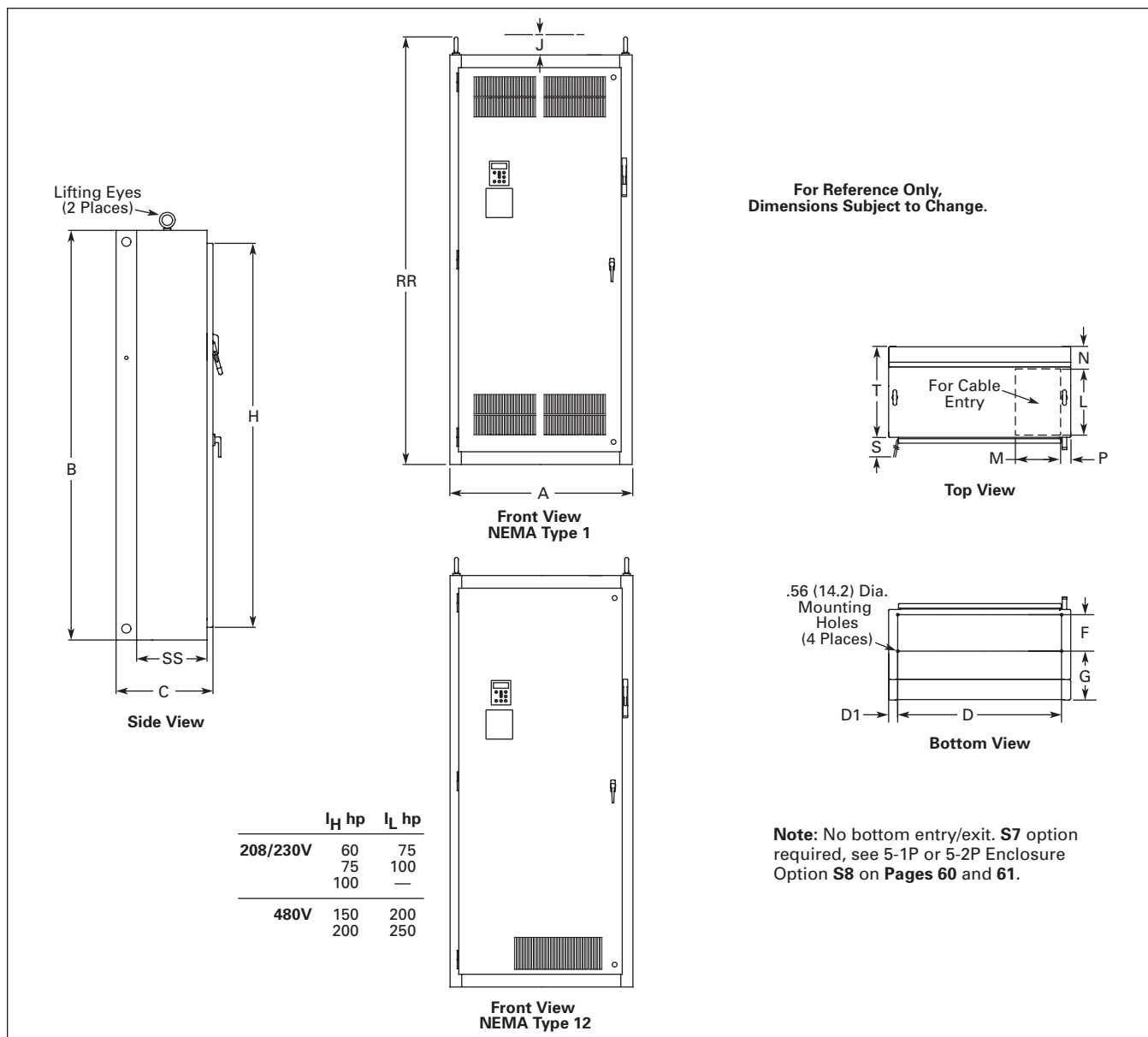

Figure 27. Approximate Dimensions

	I _H hp	I _L hp
208/230V	60	75
	75	100
	100	—
480V	150	200
	200	250

Enclosed Drives

Enclosure Size 5-1P

Table 91. Approximate Dimensions and Shipping Weight — Enclosed Products

Enclosure Size	Dimensions in Inches (mm)												Min. Air Space	
	Wide A	High B	Deep C	Mounting							H	J	K	
				D	D1	E	E1	F	G	G1				
5-1P	50.0 (1270)	90.0 (2286)	21.3 (541)	36.0 (914)	2.0 (51)	—	—	8.0 (203)	10.8 (273)	—	84.4 (2143)	4.0 (102)	—	

Table 91. Approximate Dimensions and Shipping Weight — Enclosed Products (Continued)

Enclosure Size	Dimensions in Inches (mm)														Max. Approx. Ship. Wt. lbs. (kg)	
	Cable Entry					Door Clearance S	T	U	V	W	RR	SS	TT	UU		VV
	L	M	N	P	R											
5-1P	17.1 (435)	8.0 (203)	1.3 (33)	1.0 (25)	—	36.3 (921)	20.0 (508)	18.4 (466)	1.3 (32)	—	94.0 (2387)	15.5 (394)	—	—	—	1375 (624)

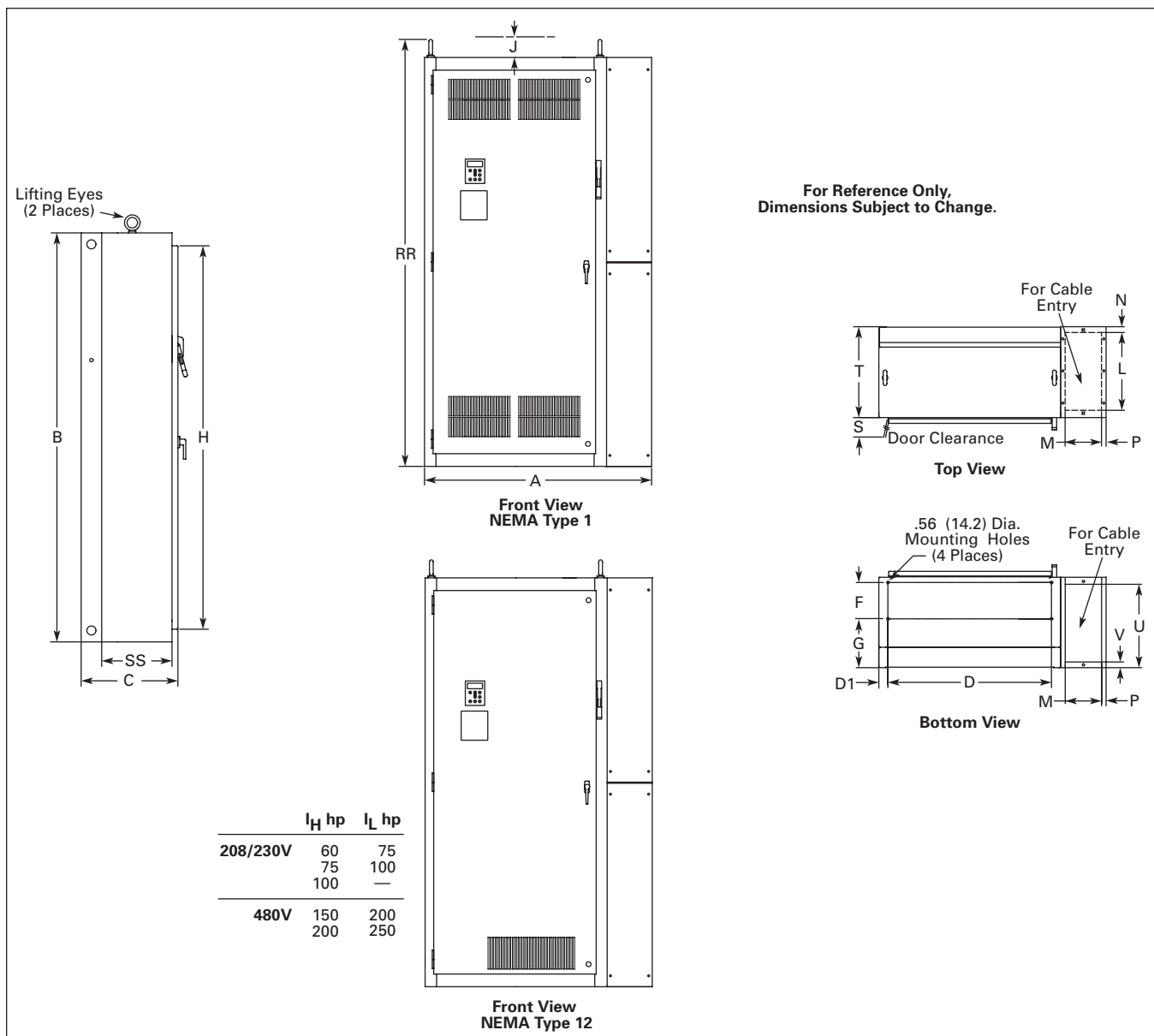

Figure 28. Approximate Dimensions

June 2006

Enclosed Drives

Enclosure Size 5-2P

Table 92. Approximate Dimensions and Shipping Weight — Enclosed Products

Enclosure Size	Dimensions in Inches (mm)											Min. Air Space	
	Wide A	High B	Deep C	Mounting							H	J	K
				D	D1	E	E1	F	G	G1			
5-2P	60.0 (1524)	90.0 (2286)	21.3 (541)	36.0 (914)	2.0 (51)	—	—	8.0 (203)	10.8 (273)	—	84.4 (2143)	4.0 (102)	—

Table 92. Approximate Dimensions and Shipping Weight — Enclosed Products (Continued)

Enclosure Size	Dimensions in Inches (mm)														Max. Approx. Ship. Wt. lbs. (kg)	
	Cable Entry					Door Clearance S	T	U	V	W	RR	SS	TT	UU		VV
	L	M	N	P	R											
5-2P	17.0 (432)	18.0 (457)	1.5 (38)	1.0 (25)	.9 (23)	36.3 (921)	20.0 (508)	18.4 (466)	1.3 (32)	—	94.0 (2387)	15.5 (394)	—	—	—	1585 (720)

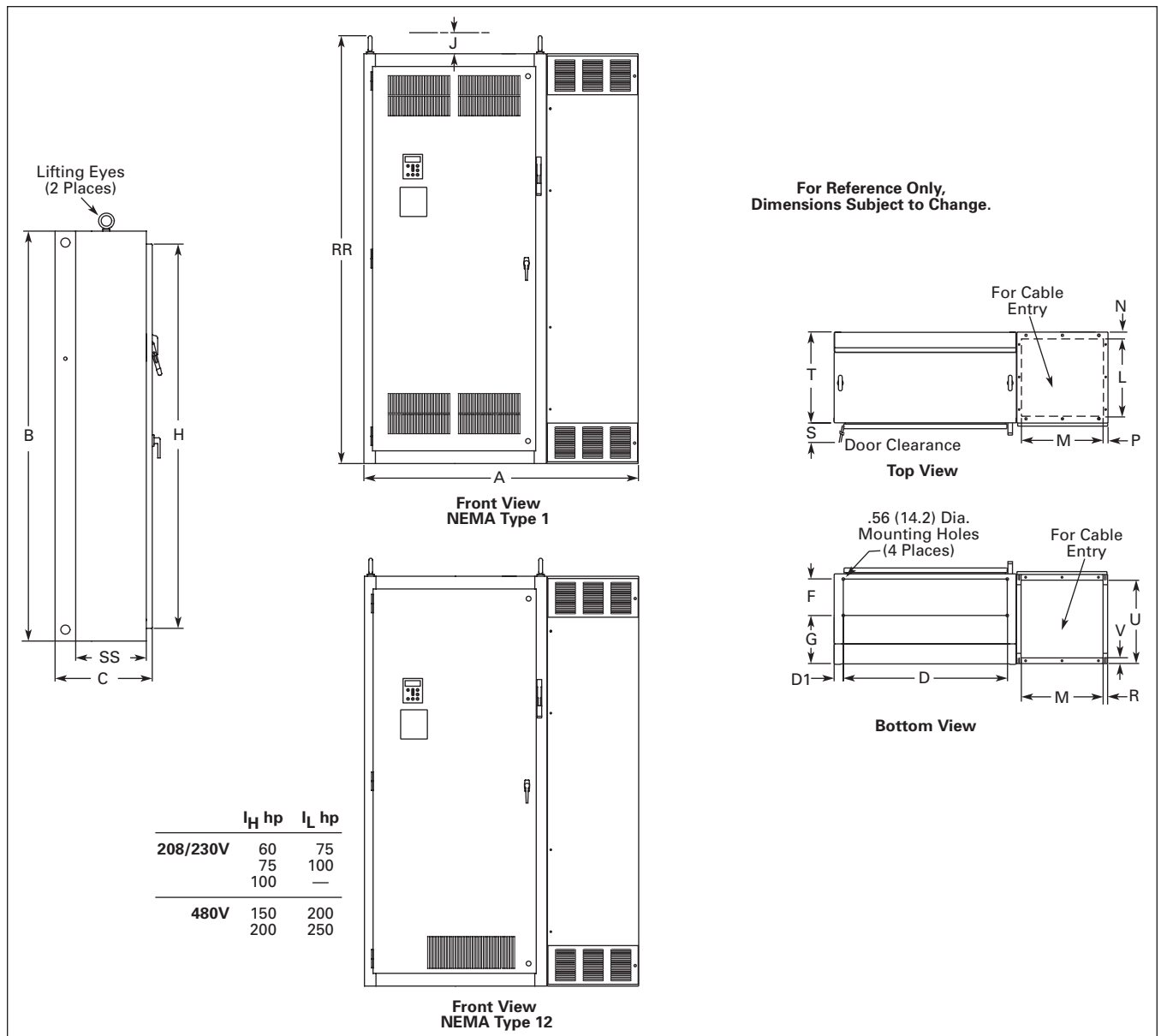

Figure 29. Approximate Dimensions

Enclosed Drives

Enclosure Size 6

Table 93. Approximate Dimensions and Shipping Weight — Enclosed Products

Enclosure Size	Dimensions in Inches (mm)			Mounting							H	Min. Air Space	
	Wide A	High B	Deep C	D	D1	D2	E	F	G	G1		J	K
6	30.0 (762)	90.0 (2286)	26.0 (660)	26.5 (673)	1.8 (46)	—	—	17.3 (438)	5.5 (140)	—	84.4 (2143)	4.0 (102)	—

Table 93. Approximate Dimensions and Shipping Weight — Enclosed Products (Continued)

Enclosure Size	Dimensions in Inches (mm)											Max. Approx. Ship. Wt. lbs. (kg)				
	Cable Entry					Door Clearance S	T	U	V	W	RR		SS	TT	UU	VV
L	M	N	P	R												
6	23.5 (597)	3.3 (84)	4.5 (114)	19.3 (490)	—	26.2 (667)	24.8 (629)	—	—	—	93.9 (2386)	—	—	—	—	1500 (681)

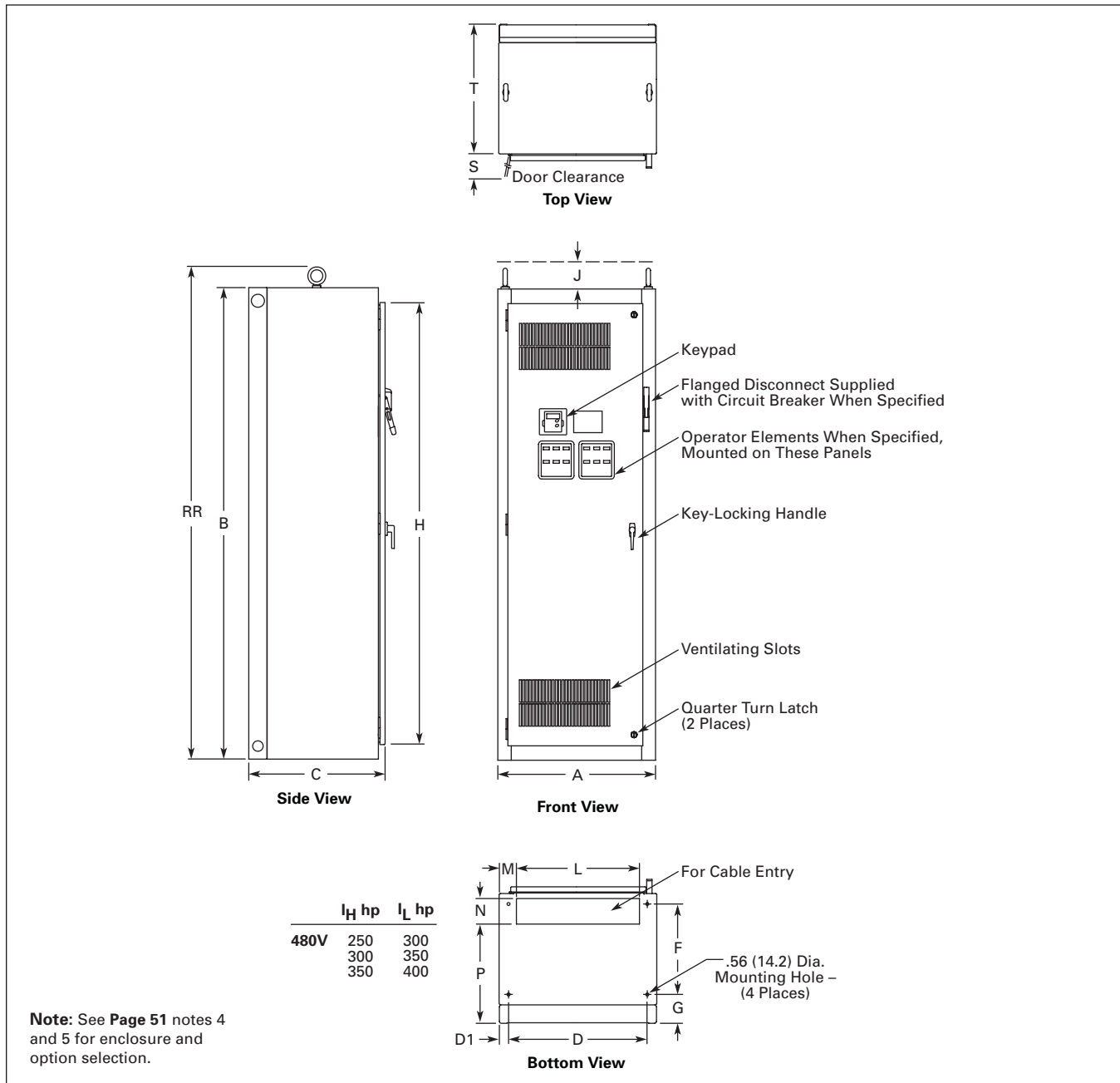

Figure 30. Approximate Dimensions

June 2006

Enclosed Drives

Enclosure Size 8

Table 94. Approximate Dimensions and Shipping Weight — Enclosed Products

Enclosure Size	Dimensions in Inches (mm)										Min. Air Space		
	Wide A	High B	Deep C	Mounting						H	J	K	
				D	D1	D2	E	F	G	G1			
8	48.0 (1219)	90.0 (2286)	24.0 (610)	42.2 (1072)	3.0 (77)	—	—	—	5.5 (139)	—	84.4 (2143)	4.0 (102)	—

Table 94. Approximate Dimensions and Shipping Weight — Enclosed Products (Continued)

Enclosure Size	Dimensions in Inches (mm)													Max. Approx. Ship. Wt. lbs. (kg)		
	Cable Entry							U	V	W	RR	SS	TT		UU	VV
	L	M	N	P	R	S	T									
8	9.5 (241)	37.5 (952)	12.5 (318)	7.7 (196)	8.3 (210)	1.3 (32)	31.0 (787)	21.5 (545)	21.3 (541)	—	93.5 (2375)	—	—	—	—	2000 (908)

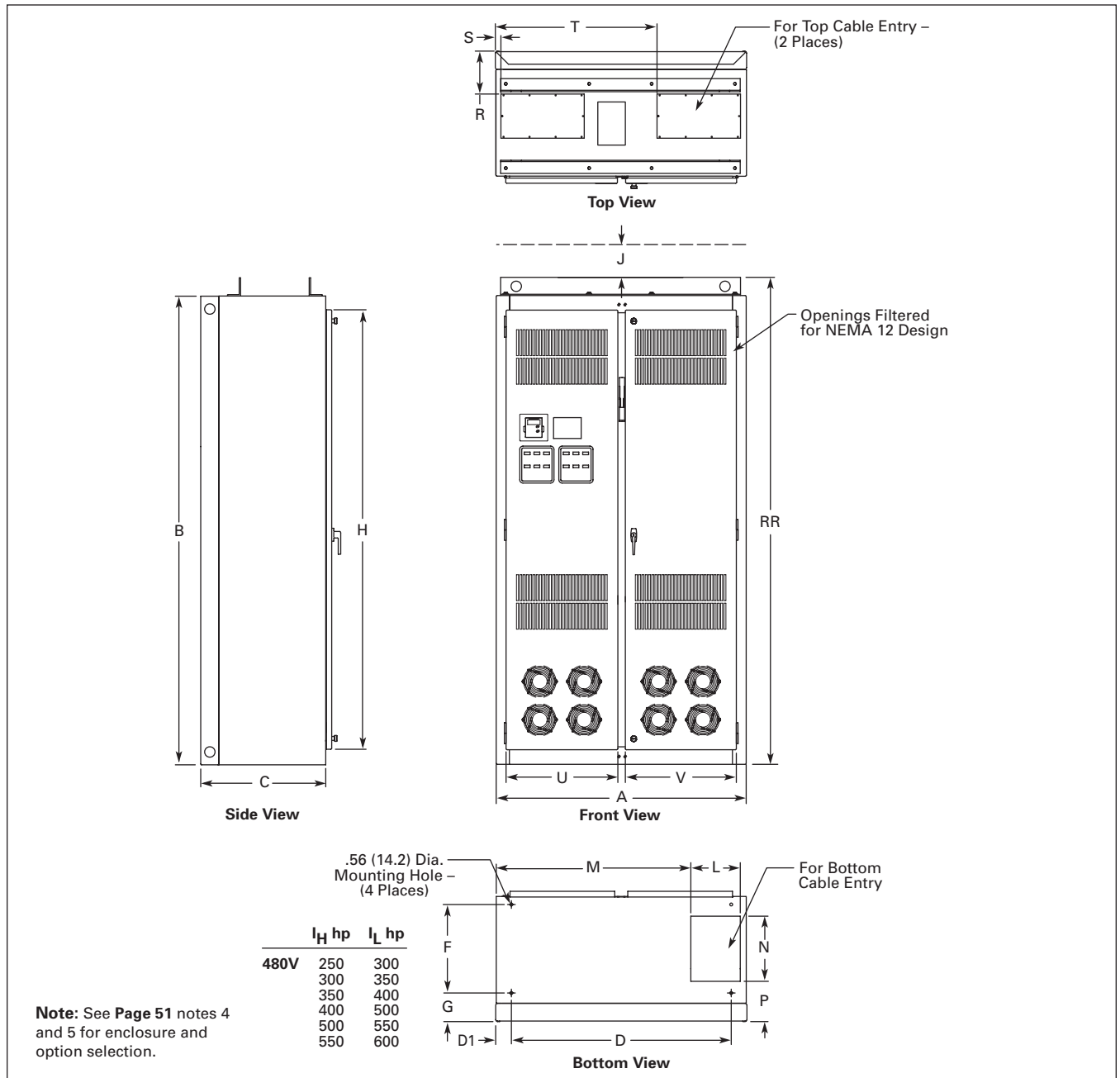

Figure 31. Approximate Dimensions

Enclosed Drives

Enclosure Size 9

Table 95. Approximate Dimensions and Shipping Weight — Enclosed Products

Enclosure Size	Dimensions in Inches (mm)										H	Min. Air Space	
	Wide A	High B	Deep C	Mounting								J	K
				D	D1	D2	E	F	G	G1			
9	60.0 (1524)	90.0 (2286)	26.1 (664)	22.9 (582)	2.0 (51)	30.0 (762)	44.3 (1125)	10.6 (270)	10.6 (270)	8.2 (208)	—	4.0 (102)	—

Table 95. Approximate Dimensions and Shipping Weight — Enclosed Products (Continued)

Enclosure Size	Dimensions in Inches (mm)														Max. Approx. Ship. Wt. lbs. (kg)	
	Cable Entry										W	RR	SS	TT		UU
	L	M	N	P	R	S	T	U	V							
9	8.5 (216)	32.7 (831)	12.0 (305)	11.9 (303)	9.8 (249)	1.5 (38)	43.5 (1105)	15.0 (381)	7.5 (191)	25.0 (635)	93.5 (2375)	27.4 (696)	29.1 (738)	27.1 (687)	—	2500 (1135)

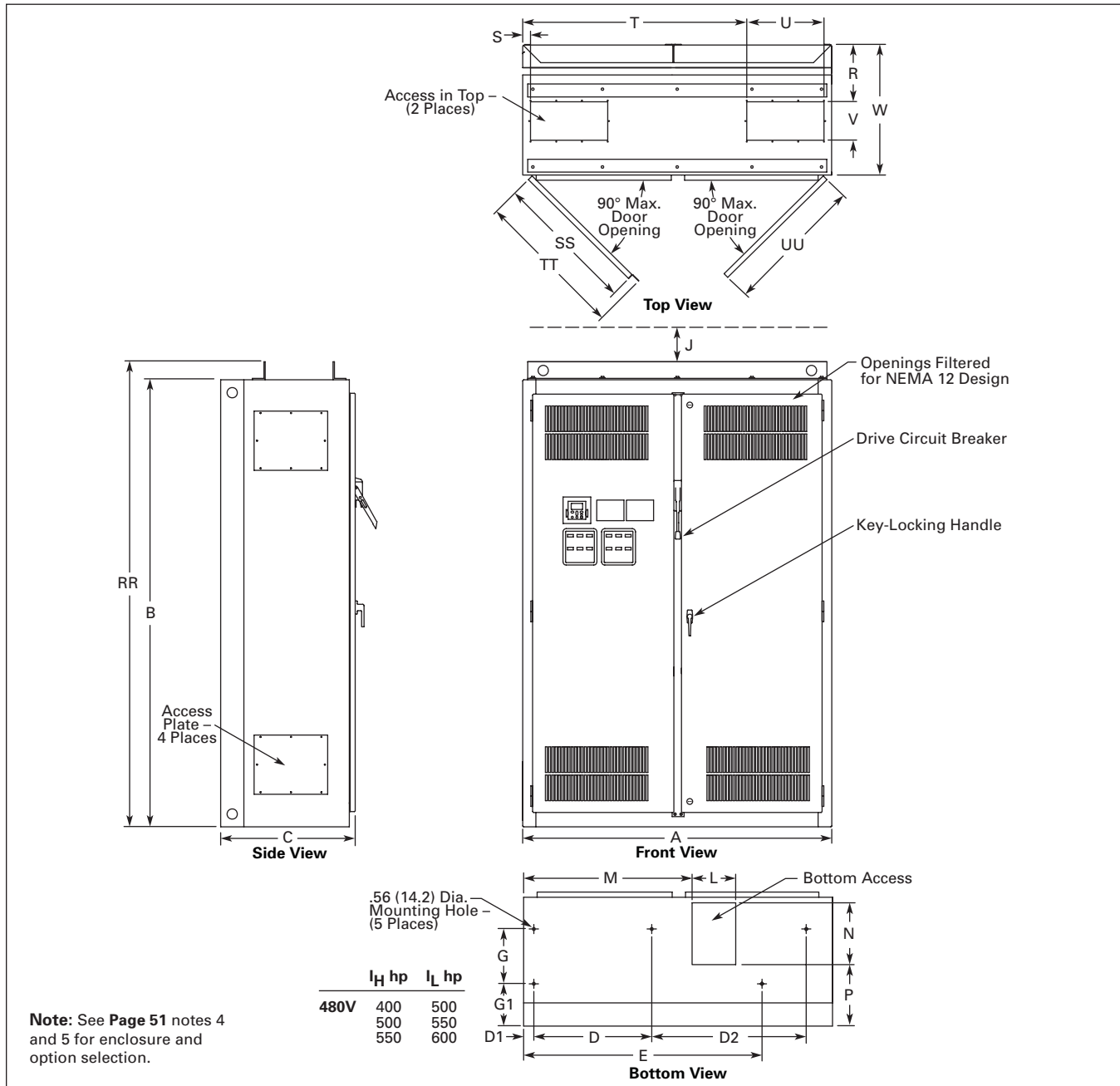
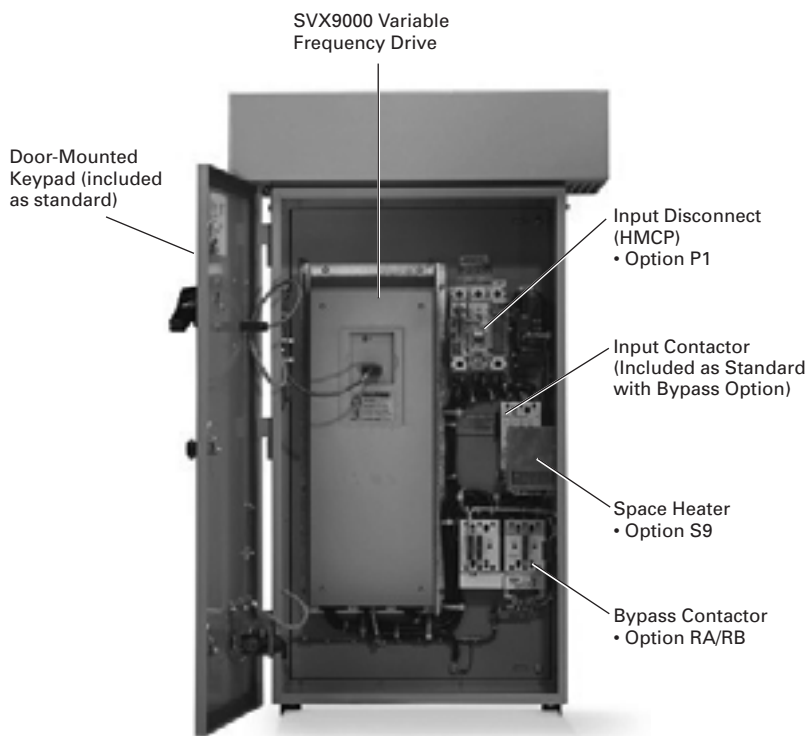

Figure 32. Approximate Dimensions

SVX9000 Pump Application



NEMA 3R Enclosed 9000X Series Drive

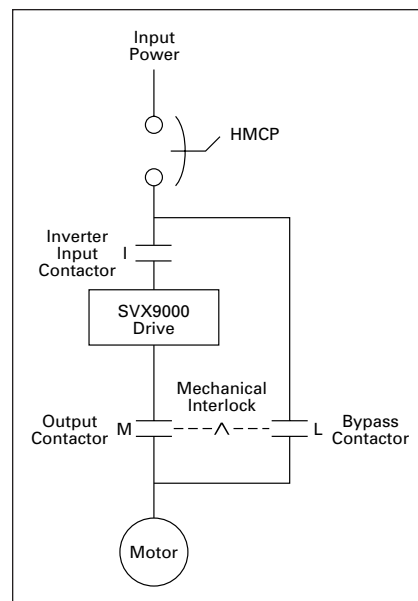

Figure 33. Power Diagram for Bypass Option RA

Product Description

- **Standard Enclosed** — covers a wide range of the most commonly ordered options. Pre-engineering eliminates the lead time normally associated with customer specific options.
- **Modified Standard Enclosed** — applies to specific customer requirements that vary from the Standard Enclosed offering, such as the need for an additional indicating light or minor modifications to drawings. *Consult your Eaton representative for assistance in pricing and lead time.*
- **Custom Engineered** — for those applications with more unique or complex requirements, these are individually engineered to the customer's needs. *Consult your Eaton representative for assistance in pricing and lead time.*

Features

- NEMA Type 12 or Type 3R enclosures
- Input Voltage: 208V, 230V, 480V and 575V (Consult Factory)
- Complete range of control, network and power options
- Horsepower range:
 - 208V — 3/4 to 100 hp I_H; 1 to 100 hp I_L
 - 230V — 3/4 to 100 hp I_H; 1 to 100 hp I_L
 - 480V — 1 to 350 hp I_H; 1-1/2 to 400 hp I_L
- HMCP padlockable
- Single Phase input available — Consult factory

Standards and Certifications

- UL Listed
- cUL Listed

VFD Pump Panels

Technical Data and Specifications

Table 96. Specifications

Feature Description	9000X Enclosed Products — NEMA Type 12 or NEMA Type 3R
Primary Design Features	
45 – 66 Hz Input Frequency	Standard
Output: AC Volts Maximum	Input Voltage Base
Output Frequency Range: Hz	0 – 320
Initial Output Current (I _H)	250% for 2 seconds
Overload: 1 Minute (I _H /I _L)	150%/110%
Enclosure Space Heater	Optional
Oversize Enclosure	Standard
Output Contactor	Optional
Bypass Motor Starter	Optional
Listings	UL, cUL
Protection Features	
Incoming Line Fuses	Optional
AC Input Circuit Disconnect	Optional
Line Reactors	Standard
Phase Rotation Insensitive	Standard
EMI Filter	Standard — Thru Frame 9
Input Phase Loss Protection	Standard
Input Overvoltage Protection	Standard
Line Surge Protection	Standard
Output Short Circuit Protection	Standard
Output Ground Fault Protection	Standard
Output Phase Protection	Standard
Overtemperature Protection	Standard
DC Overvoltage Protection	Standard
Drive Overload Protection	Standard
Motor Overload Protection	Standard
Programmer Software	Optional
Local/Remote Keypad	Standard
Keypad Lockout	Standard
Fault Alarm Output	Standard
Built-In Diagnostics	Standard
Input/Output Interface Features	
Setup Adjustment Provisions: Remote Keypad/Display Personal Computer	Standard Standard
Operator Control Provisions: Drive Mounted Keypad/Display Remote Keypad/Display Conventional Control Elements Serial Communications 115V AC Control Circuit	Standard Standard Standard Optional Optional
Speed Setting Inputs: Keypad 0 – 10V DC Potentiometer/ Voltage Signal 4 – 20 mA Isolated 4 – 20 mA Differential	Standard Standard Configurable Configurable
Analog Outputs: Speed/Frequency Torque/Load/Current Motor Voltage Kilowatts 0 – 10V DC Signals 4 – 20 mA DC Signals Isolated Signals	Standard Programmable Programmable Programmable Configurable w/Jumpers Standard Optional

Feature Description	9000X Enclosed Products — NEMA Type 12 or NEMA Type 3R
---------------------	---

Input/Output Interface Features (Continued)

Discrete Outputs: Fault Alarm Drive Running Drive at Set Speed Optional Parameters Dry Contacts Open Collector Outputs Additional Discrete Outputs	Standard Standard Programmable 14 1 (2 Relays Form C) 1 Optional
Communications: RS-232 RS-422/485 DeviceNet™ Modbus RTU CanOpen (Slave) Profibus-DP Lonworks® Johnson Controls Metasys™ N2	Standard Optional Optional Optional Optional Optional Optional Optional

Performance Features

Sensorless Vector Control	Standard
Volts/Hertz Control	Standard
IR and Slip Compensation	Standard
Electronic Reversing	Standard
Dynamic Braking	Optional ①
DC Braking	Standard
PID Setpoint Controller	Programmable
Critical Speed Lockout	Standard
Current (Torque) Limit	Standard
Adjustable Acceleration/Deceleration	Standard
Linear or S Curve Accel/Decel	Standard
Jog at Preset Speed	Standard
Thread/Preset Speeds	7
Automatic Restart	Selectable
Coasting Motor Start	Standard
Coast or Ramp Stop Selection	Standard
Elapsed Time Meter	Optional
Carrier Frequency Adjustment	1 – 16 kHz

Standard Conditions for Application and Service

Operating Ambient Temperature	0 – 40°C
Storage Temperature	-40 – 60°C
Humidity (Maximum), Non-condensing	95%
Altitude (Maximum without Derate)	3300 ft. (1000m)
Line Voltage Variation	+10/-15%
Line Frequency Variation	45 – 66 Hz
Efficiency	>96%
Power Factor (Displacement)	.96

① Some horsepower units include dynamic braking chopper as standard — refer to individual drive sections.

Table 97. Standard I/O Specifications

Description	Specification
6 – Digital Input Programmable	24V: "0" ≤ 10V, "1" ≥ 18V, R _i > 5 kΩ
2 – Analog Input Configurable w/Jumpers	Voltage: 0 – ±10V, R _i > 200 kΩ Current: 0 (4) – 20 mA, R _i = 250 kΩ
2 – Digital Output Programmable	Form C Relays 250V AC 2 Amp or 30V DC 2 Amp resistive
1 – Digital Output Programmable	Open collector 48V DC 50 mA
1 – Analog Output Programmable Configurable w/Jumper	0 – 20 mA, impedance 500 ohms, resolution 106 ±3%

Catalog Number Selection

Table 98. SVX9000 Enclosed NEMA Type 12/3R Drive Catalog Numbering System

SVX 010 2 4 E P

Product Family

SVX = Enclosed Drives

Horsepower Rating

F07 = 3/4 hp	010 = 10 hp	060 = 60 hp
001 = 1 hp	015 = 15 hp	075 = 75 hp
F15 = 1-1/2 hp	020 = 20 hp	100 = 100 hp
002 = 2 hp	025 = 25 hp	125 = 125 hp
003 = 3 hp	030 = 30 hp	150 = 150 hp
005 = 5 hp	040 = 40 hp	200 = 200 hp
007 = 7-1/2 hp	050 = 50 hp	

Consult Factory^①

250 = 250 hp	350 = 350 hp
300 = 300 hp	400 = 400 hp

Enclosure Rating

2 = NEMA Type 12
3 = NEMA Type 3R

Voltage Rating

Three-Phase	Single-Phase
1 = 208V	J = 230V
2 = 230V	K = 480V
4 = 480V	

Application — Torque/Braking^③

A = I_L/No Brake Chopper
 B = I_L/Internal Brake Chopper
 D = I_H/No Brake Chopper
 E = I_H/Internal Brake Chopper

Enclosed Style

P = Pumping Application

Build Alphabetically and Numerically

Enclosed Options ^{②⑤⑥}		Type
K1	Door-Mounted Speed Potentiometer ^④	Control
K2	Door-Mounted Speed Potentiometer with HOA Selector Switch ^④	Control
K5	Manual/Auto Reference Switch (22 mm)	Control
K6	Start & Stop Pushbuttons (22 mm)	Control
K9	(2) Factory Installed Auxiliary Contacts	Power
L1	Power On and Fault Pilot Lights	Light
L2	Bypass Pilot Lights for RA Bypass Option ^⑥	Light
LD	Green Stop Light	Addl. Bypass
LE	Red Run Light	Light
LU	Light (22 mm)	Light
LW	PTT Light (22 mm)	Light
LY	Adder for LED Each	Light
P1	Input Disconnect (HMCP) 100 kAIC	Input
P3	Input Line Fuses (200 kAIC)	Input
P7	Input Power Surge Protection	Input
P8	TVSS Transient Voltage Surge Suppressor	Input
PE	Output Contactor	Output
RA	Manual HOA Bypass Controller ^⑥	Bypass
S5	Floor Stand 22"	Enclosure
S9	Space Heater w/out CPT	Enclosure
SA	Space Heater w/CPT	Enclosure
SB	Socket Type Control Relay	Enclosure
SE	On-Delay Timer	Enclosure
SF	Off-Delay Timer	Enclosure

Communication Options^⑦

C2 = Modbus
 C3 = Profibus DP
 C4 = LonWorks
 C5 = Profibus DP (D9 Connector)
 C6 = CanOpen (Slave)
 C7 = DeviceNet
 C8 = Modbus (D9 Type Connector)
 CA = Johnson Controls N2
 CI = Modbus TCP
 CJ = BACnet
 CK = Ethernet IP
 D3 = RS-232 with D9 Connection

Control Options

B1 = 6 DI, 1 ext +24V DC/EXT +24V DC
 B2 = 1 RO (NC/NO), 1 RO (NO), 1 Therm
 B4 = 1 AI (mA isolated), 2 AO (mA isolated), 1 ext +24V DC/EXT +24V DC
 B5 = 3 RO (NO)
 B8 = 1 ext +24V DC/EXT +24V DC, 3 Pt100
 B9 = 1 RO (NO), 5 DI 42 – 240V AC Input

① Consult factory.
 ② Local/Remote keypad is included as the standard Control Panel.
 ③ Brake Chopper is a factory installed option only, see drive option tables on **Pages 71 – 76**. **Note:** External dynamic braking resistors not included. Consult factory.
 ④ Includes local/remote speed reference switch.
 ⑤ Some options are voltage and/or horsepower specific. Consult your Eaton representative for details.
 ⑥ See **Page 68** for descriptions.
 ⑦ See **Pages 69 and 70** for complete descriptions.
 ⑧ Bypass options applicable only in the Pump Panel three-phase design.

VFD Pump Panels

Control/Communication Option Descriptions

Table 99. Available Control/Communications Options

Option	Description	Option Type
K1	Door-Mounted Speed Potentiometer — Provides the SVX9000 with the ability to adjust the frequency reference using a door-mounted potentiometer. This option uses the 10V DC reference to generate a 0 – 10V signal at the analog voltage input signal terminal. When the HOA bypass option is added, the speed is controlled when the HOA switch is in the hand position. Without the HOA bypass option, a 2-position switch (labeled local/remote) is provided on the keypad to select speed reference from the Speed Potentiometer or a remote speed signal.	Control
K2	Door-Mounted Speed Potentiometer with HOA Selector Switch — Provides the SVX9000 with the ability to start/stop and adjust the speed reference from door-mounted control devices or remotely from customer supplied inputs. In HAND position, the drive will start and the speed is controlled by the door-mounted speed potentiometer. The drive will be disabled in the OFF position. When AUTO is selected, the drive run and speed control commands are via user-supplied dry contact and 4 – 20 mA signal.	Control
K5	Manual/Auto Speed Reference Switch — Provides a door-mounted selector switch for Manual/Auto speed reference.	Control
K6	Start & Stop Pushbuttons (22 mm) — Start (green) and Stop (red). Provides door-mounted Start and Stop pushbuttons for either bypass or non-bypass configurations.	Control
K9	(2) Factory Installed Auxiliary Contacts — Provides two NO/NC auxiliary contacts.	Power
L1	Power On and Fault Pilot Lights — Provides a white power on light that indicates power to the enclosed cabinet and a red fault light indicates a drive fault has occurred.	Light
L2	Bypass Pilot Lights for RB, RA Bypass Options — A green light indicates when the motor is running in inverter mode and an amber light indicates when the motor is running in bypass mode. The lights are mounted on the enclosure door, above the switches.	Addl. Bypass
LD	Green Stop Light (22 mm) — Provides a green light that indicates the drive is stopped.	Light
LE	Run Pilot Light (22 mm) — Provides a red run light that indicates the drive is running.	Light
LU	Misc. Light (22 mm) — Provides misc. “user defined” pilot light. User to define light function and color.	Light
LW	PTT (Push-To-Test) Light (22 mm) — Provides misc. “user defined” PTT pilot light. User to define light function and color.	Light
LY	Adder for LED Each — Changes light packages from standard incandescent bulb to LED style bulb.	Light
P1	Input Disconnect Assembly Rated to 100 kAIC — High Interrupting Motor Circuit Protector (HMCP) that provides a means of short circuit protection for the power cables between it and the SVX9000, and protection from high-level ground faults on the power cable. Allows a convenient means of disconnecting the SVX9000 from the line and the operating mechanism can be padlocked in the OFF position. This is factory mounted in the enclosure.	Input
P3	Input Line Fuses Rated to 200 kAIC — Provides high-level fault protection of the SVX9000 input power circuit from the load side of the fuses to the input side of the power transistors. This option consists of three 200 kA fuses, which are factory mounted in the enclosure.	Input
P7	MOV Surge Suppressor — Provides a Metal Oxide Varistor (MOV) connected to the line side terminals and is designed to clip line side transients.	Input
P8	TVSS Transient Voltage Surge Suppressor — Provides transient voltage surge suppression of the unit. Consult factory for ratings.	Input
PE	Output Contactor — Provides a means for positive disconnection of the drive output from the motor terminals. The contactor coil is controlled by the drive’s run or permissive logic. NC and NO auxiliary contacts rated at 10A, 600V AC are provided for customer use. Bypass Option RA includes an Output Contactor as standard. This option includes a low VA 115V AC fused Control Power Transformer and is factory mounted in the enclosure.	Output
RA	Manual HOA Bypass Controller — The Manual HAND/OFF/AUTO (HOA) — 3-contactor — bypass option provides a means of bypassing the SVX9000, allowing the AC motor to be operated at full speed directly from the AC supply line. This option consists of an input disconnect, a fused control power transformer, and a full voltage bypass starter with a door mounted HOA selector switch and an INVERTER/BYPASS switch. The HOA switch provides the ability to start and stop the drive in the inverter mode. For applications up to 100 hp, a Freedom Series IEC input contactor, a Freedom Series IEC output contactor, and a Freedom Series IEC starter with a bimetallic overload relay is included. For applications above 100 hp, an Advantage input contactor, an Advantage output contactor and an Advantage starter with electronic overload protection is included. The contactors are mechanically and electrically interlocked (see power diagram on Page 65).	Bypass
S5	Floor Stand 22" — Converts a Size A or B, normally wall mounted enclosure to a floor standing enclosure with a height of 22" (558.8 mm).	Enclosure
S9	Space Heater without CPT — Prevents condensation from forming in the enclosure when the drive is inactive or in storage. Includes a thermostat for variable temperature control. A 200W heater is installed in enclosures A and B, and 400W heater is installed in enclosures C – D. Requires a customer supplied 115V remote supply source.	Enclosure
SA	Space Heater with CPT — Prevents condensation from forming in the enclosure when the drive is inactive or in storage. Includes a thermostat for variable temperature control. A 200W heater is installed in enclosures A and B, and 400W heater is installed in enclosures C – D. Provided with CPT connected to load side of input disconnect.	Enclosure
SB	Ice Cube Style Control Relay — Provides misc. “user defined” 4PDT control relay. Requires user to define functionality.	Enclosure
SE	On-Delay Timer (Delay on Make) — Provides misc. “user defined” time delay relay. Requires user to define functionality and time setting requirement.	Enclosure
SF	Off-Delay Timer (Delay on Break) — Provides misc. “user defined” time delay relay. Requires user to define functionality and time setting requirement.	Enclosure

Note: For availability, see Product Selection for base drive voltage required.

June 2006

VFD Pump Panels

9000X Series Option Board Kits

The 9000X Series drives can accommodate a wide selection of expander and adapter option boards to customize the drive for your application needs. The drive's control unit is designed to accept a total of five option boards (see Figure 34).

The 9000X Series factory installed standard board configuration includes an A9 I/O board and an A2 relay output board, which are installed in slots A and B.

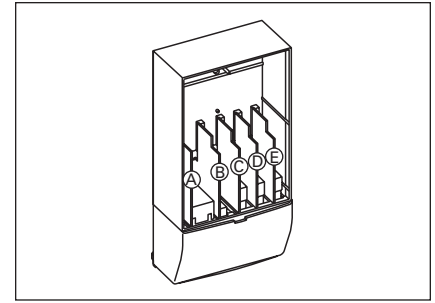

Figure 34. 9000X Series Option Boards

Table 100. Option Board Kits

Option Kit Description ②	Allowed Slot Locations ①	Field Installed		Factory Installed		SVX Ready Programs						
		Catalog Number	Price U.S. \$	Option Designator	Adder U.S. \$	Basic	Local/Remote	Standard	MSS	PID	Multi-P.	PFC
Standard I/O Cards (See Figure 34)												
2 RO (NC/NO)	B	OPTA2		—		X	X	X	X	X	X	X
6 DI, 1 DO, 2 AI, 1AO, 1 +10V DC ref, 2 ext +24V DC/ EXT +24V DC	A	OPTA9		—		X	X	X	X	X	X	X
Extended I/O Card Options												
6 DI, 1 ext +24V DC/EXT +24V DC	B, C, D, E	OPTB1		B1		—	—	—	—	—	X	X
1 RO (NC/NO), 1 RO (NO), 1 Therm	B, C, D, E	OPTB2		B2		—	—	—	—	—	X	X
1 AI (mA isolated), 2 AO (mA isolated), 1 ext +24V DC/EXT +24V DC	B, C, D, E	OPTB4		B4		X	X	X	X	X	X	X
3 RO (NO)	B, C, D, E	OPTB5		B5		—	—	—	—	—	X	X
1 ext +24V DC/EXT +24V DC, 3 Pt100	B, C, D, E	OPTB8		B8		—	—	—	—	—	—	—
1 RO (NO), 5 DI 42 – 240V AC Input	B, C, D, E	OPTB9		B9		—	—	—	—	—	X	X
Communication Cards ③												
Modbus	D, E	OPTC2		C2		X	X	X	X	X	X	X
Modbus TCP	D, E	OPTCI		CI		X	X	X	X	X	X	X
BACnet	D, E	OPTCJ		CJ		X	X	X	X	X	X	X
Ethernet IP	D, E	OPTCK		CK		X	X	X	X	X	X	X
Johnson Controls N2	D, E	OPTC2		CA		—	—	—	—	—	—	—
Profibus DP	D, E	OPTC3		C3		X	X	X	X	X	X	X
LonWorks	D, E	OPTC4		C4		X	X	X	X	X	X	X
Profibus DP (D9 Connector)	D, E	OPTC5		C5		X	X	X	X	X	X	X
CanOpen (Slave)	D, E	OPTC6		C6		X	X	X	X	X	X	X
DeviceNet	D, E	OPTC7		C7		X	X	X	X	X	X	X
Modbus (D9 Type Connector)	D, E	OPTC8		C8		X	X	X	X	X	X	X
RS-232 with D9 Connection	D, E	OPTD3		D3		X	X	X	X	X	X	X
Keypad												
9000X Series Local Remote Keypad	—	KEYPAD-LOC/REM		—		—	—	—	—	—	—	—
9000X Series Remote Mount Keypad Kit (Keypad not included)	—	OPTRMT-KIT-9000X		—		—	—	—	—	—	—	—
9000X Series RS-232 Cable, 13 ft.	—	PP00104		—		—	—	—	—	—	—	—

① Option card must be installed in one of the slots listed for that card. Slot indicated in Bold is the preferred location.

② AI = Analog Input; AO = Analog Output, DI = Digital Input, DO = Digital Output, RO = Relay Output

③ OPTC2 is a multi-protocol option card.

VFD Pump Panels

Modbus RTU Network Communications

The Modbus Network Card OPTC2 is used for connecting the 9000X Drive as a slave on a Modbus network. The interface is connected by a 9-pin DSUB connector (female) and the baud rate ranges from 300 to 19200 baud. Other communication parameters include an address range from 1 to 247; a parity of None, Odd or Even; and the stop bit is 1.

Profibus Network Communications

The Profibus Network Card OPTC3 is used for connecting the 9000X Drive as a slave on a Profibus-DP network. The interface is connected by a 9-pin DSUB connector (female). The baud rates range from 9.6K baud to 12M baud, and the addresses range from 1 to 127.

LonWorks Network Communications

The LonWorks Network Card OPTC4 is used for connecting the 9000X Drive on a LonWorks network. This interface uses Standard Network Variable Types (SNVT) as data types. The channel connection is achieved using a FTT-10A Free Topology transceiver via a single twisted transfer cable. The communication speed with LonWorks is 78 kBits/s.

CanOpen (Slave) Communications

The CanOpen (Slave) Network Card OPTC6 is used for connecting the 9000X Drive to a host system. According to ISO11898 standard cables to be chosen for CAN bus should have a nominal impedance of 120Ω, and specific line delay of nominal 5 nS/m. 120Ω line termination resistors required for installation.

DeviceNet Network Communications

The DeviceNet Network Card OPTC7 is used for connecting the 9000X Drive on a DeviceNet Network. It includes a 5.08 mm pluggable connector. Transfer method is via CAN using a 2-wire twisted shielded cable with 2-wire bus power cable and drain. The baud rates used for communication include 125K baud, 250K baud and 500K baud.

Johnson Controls Metasys™ N2 Network Communications

The OPTC2 fieldbus board provides communication between the 9000X Drive and a Johnson Controls Metasys™ N2 network. With this connection, the drive can be controlled, monitored and programmed from the Metasys system. The N2 fieldbus is available as a factory installed option and as a field installable kit.

Modbus/TCP Network Communications

The Modbus/TCP Network Card OPTC1 is used for connecting the 9000X Drive to Ethernet networks utilizing Modbus protocol. It includes an RJ-45 pluggable connector. This interface provides a selection of standard and custom register values to communicate drive parameters. The board supports 10 Mbps and 100 Mbps communication speeds. The IP address of the board is configurable over Ethernet using a supplied software tool.

BACnet Network Communications

The BACnet Network Card OPTCJ is used for connecting the 9000X Drive to BACnet networks. It includes a 5.08 mm pluggable connector. Data transfer is Master-Slave/Token Passing (MS/TP) RS-485. This interface uses a collection of 30 Binary Value

Objects (BVOs) and 35 Analog Value Objects (AVOs) to communicate drive parameters. The card supports 9.6, 19.2 and 38.4 Kbaud communication speeds and supports network addresses 1 – 127.

Ethernet/IP Network Communications

The Ethernet/IP Network Card OPTCK is used for connecting the 9000X Drive to Ethernet/Industrial Protocol networks. It includes an RJ-45 pluggable connector. The interface uses CIP objects to communicate drive parameters (CIP is “Common Industrial Protocol”, the same protocol used by DeviceNet). The board supports 10 Mbps and 100 Mbps communication speeds. The IP address of the board is configurable by Static, BOOTP and DHCP methods.

Table 101. I/O Specifications for the Control/Communication Options

Description	Specifications
Analog voltage, input	0 – ±10V, R _i ≥ 200 kΩ
Analog current, input	0 (4) – 20 mA, R _i = 250 Ω
Digital Input	24V: “0” ≤ 10V, “1” ≥ 18V, R _i > 5 kΩ
Aux. voltage	24V (±20%), max. 50 mA
Reference voltage	10V ±3%, max. 10 mA
Analog current, output	0 (4) – 20 mA, R _L = 500 kΩ, resolution 10 bit, accuracy ≤ ±2%
Analog voltage, output	0 (2) – 10V, R _L ≥ 1 kΩ, resolution 10 bit, accuracy ≤ ±2%
Relay output	300V DC, 250V AC
Max. switching voltage	8A/24V DC, .4A/300V DC, 2 kVA/250V AC
Max. switching load	
Max. continuous load	2A rms
Thermistor input	R _{trip} = 4.7 kΩ

Product Selection

When Ordering

- Select a Base Catalog Number that meets the application requirements — nominal horsepower, voltage and enclosure rating (the enclosed drive's continuous output amp rating should be equal to or greater than the motor's full load amp rating). The base enclosed package includes a standard drive, door mounted Local/Remote Keypad and enclosure.
- If Dynamic Brake Chopper or Control/Communication option is desired, change the appropriate code in the Base Catalog Number.
- Select Enclosed Options. Add the codes as suffixes to the Base Catalog Number in alphabetical and numeric order.
- **Read all Footnotes.**

208V Drives

Table 102. 208V Pump Panel Style (Three-Phase)

Enclosure Size ①	hp	NEMA Type 12			NEMA Type 3R		
		Frame Size	Base Catalog Number ②	Price U.S. \$ ②	Frame Size	Base Catalog Number ②	Price U.S. \$ ②
208V High Overload Drive and Enclosure							
A	3/4	4	SVXF0721EP		4	SVXF0731EP	
A	1		SVX00121EP			SVX00131EP	
A	1-1/2		SVXF1521EP			SVXF1531EP	
A	2		SVX00221EP			SVX00231EP	
A	3	5	SVX00321EP		5	SVX00331EP	
A	5		SVX00521EP			SVX00531EP	
A	7-1/2		SVX00721EP			SVX00731EP	
A	10	6	SVX01021EP		6	SVX01031EP	
B	15		SVX01521EP			SVX01531EP	
B	20	7	SVX02021DP		7	SVX02031DP	
B	25		SVX02521DP			SVX02531DP	
C	30		SVX03021DP			SVX03031DP	
C	40	8	SVX04021DP		8	SVX04031DP	
C	50		SVX05021DP			SVX05031DP	
D	60		SVX06021DP			SVX06031DP	
D	75	9	SVX07521DP		9	SVX07531DP	
D	100		SVX10021DP			SVX10031DP	

208V Low Overload Drive and Enclosure

A	1	4	SVX00121BP		4	SVX00131BP	
A	1-1/2		SVXF1521BP			SVXF1531BP	
A	2		SVX00221BP			SVX00231BP	
A	3		SVX00321BP			SVX00331BP	
A	5	5	SVX00521BP		5	SVX00531BP	
A	7-1/2		SVX00721BP			SVX00731BP	
A	10		SVX01021BP			SVX01031BP	
A	15	6	SVX01521BP		6	SVX01531BP	
B	20		SVX02021BP			SVX02031BP	
B	25	7	SVX02521AP		7	SVX02531AP	
B	30		SVX03021AP			SVX03031AP	
C	40		SVX04021AP			SVX04031AP	
C	50	8	SVX05021AP		8	SVX05031AP	
C	60		SVX06021AP			SVX06031AP	
D	75		SVX07521AP			SVX07531AP	
D	100	9	SVX10021AP		9	SVX10031AP	

① Enclosure dimensions listed on **Pages 77 – 82.**

② Includes drive, Local/Remote Keypad and enclosure.

Table 103. 208V Brake Chopper Adder ③

I _H hp	Adder U.S. \$	I _L hp	Adder U.S. \$
	NEMA Type 12/3R		NEMA Type 12/3R
3/4		—	
1		1	
1-1/2		1-1/2	
2		2	
3		3	
5		5	
7-1/2		7-1/2	
10		10	
15		15	
20		20	
25		25	
30		30	
40		40	
50		50	
60		60	
75		75	
100		100	

③ External dynamic braking resistors not included. Consult factory.

VFD Pump Panels

Table 104. 208V Control Options

Catalog Number Suffix	Door-Mounted Speed Potentiometer	Door-Mounted Speed Potentiometer with HOA Selector Switch	Manual/Auto Reference Switch (22 mm)	Start & Stop Pushbuttons (22 mm)
hp	Adder U.S. \$	Adder U.S. \$	Adder U.S. \$	Adder U.S. \$
3/4 – 100				

Table 105. 208V Light Options

Catalog Number Suffix	Power On/Fault Pilot Lights (22 mm)	Green Stop Light (22 mm)	Red Run Light (22 mm)	Misc. Light (22 mm)	PTT Light (22 mm)	Adder for LED Each
hp	Adder U.S. \$	Adder U.S. \$	Adder U.S. \$	Adder U.S. \$	Adder U.S. \$	Adder U.S. \$
3/4 – 100						

Table 106. 208V Enclosure Options

Catalog Number Suffix	Floor Stand 22" (558.8 mm)	Space Heater w/out CPT	Space Heater w/CPT	Socket Type Control Relay	On-Delay Timer	Off-Delay Timer
hp	Adder U.S. \$	Adder U.S. \$	Adder U.S. \$	Adder U.S. \$	Adder U.S. \$	Adder U.S. \$
A						
B						
C						
D						

Table 107. 208V Power Options

Catalog Number Suffix	Input					Output
	Two Auxiliary Contacts Installed	Input Disconnect (HMCP) 100 kAIC	Input Line Fuses 200 kAIC	Input Power Surge Protection	TVSS Transient Voltage Surge Suppressor	Output Contactor
hp	Adder U.S. \$	Adder U.S. \$	Adder U.S. \$	Adder U.S. \$	Adder U.S. \$	Adder U.S. \$
3/4 – 5						
7-1/2						
10						
15						
20						
25 – 30						
40						
50 – 60						
75						
100						

Table 108. 208V Bypass Options

Catalog Number Suffix	Bypass Pilot Lights for RA Option	Manual HOA Bypass Controller
hp	Adder U.S. \$	Adder U.S. \$
3/4 – 7-1/2		
10		
15 – 20		
25 – 30		
40		
50 – 60		
75		
100		

Discount Symbol..... SS-2

230V Drives

Table 109. 230V Pump Panel Style (Three-Phase)

Enclosure Size ①	hp	NEMA Type 12			NEMA Type 3R		
		Frame Size	Base Catalog Number ②	Price U.S. \$ ②	Frame Size	Base Catalog Number ②	Price U.S. \$ ②
A	3/4	4	SVXF0722EP		4	SVXF0732EP	
A	1		SVX00122EP			SVX00132EP	
A	1-1/2		SVXF1522EP			SVXF1532EP	
A	2		SVX00222EP			SVX00232EP	
A	3	5	SVX00322EP		5	SVX00332EP	
A	5		SVX00522EP			SVX00532EP	
A	7-1/2		SVX00722EP			SVX00732EP	
A	10	6	SVX01022EP		6	SVX01032EP	
B	15		SVX01522EP			SVX01532EP	
B	20	7	SVX02022DP		7	SVX02032DP	
B	25		SVX02522DP			SVX02532DP	
C	30		SVX03022DP			SVX03032DP	
C	40	8	SVX04022DP		8	SVX04032DP	
C	50		SVX05022DP			SVX05032DP	
D	60		SVX06022DP			SVX06032DP	
D	75	9	SVX07522DP		9	SVX07532DP	
D	100		SVX10022DP			SVX10032DP	

230V High Overload Drive and Enclosure

A	1	4	SVX00122BP		4	SVX00132BP	
A	1-1/2		SVXF1522BP			SVXF1532BP	
A	2		SVX00222BP			SVX00232BP	
A	3		SVX00322BP			SVX00332BP	
A	5	5	SVX00522BP		5	SVX00532BP	
A	7-1/2		SVX00722BP			SVX00732BP	
A	10		SVX01022BP			SVX01032BP	
A	15	6	SVX01522BP		6	SVX01532BP	
B	20		SVX02022BP			SVX02032BP	
B	25	7	SVX02522AP		7	SVX02532AP	
B	30		SVX03022AP			SVX03032AP	
C	40		SVX04022AP			SVX04032AP	
C	50	8	SVX05022AP		8	SVX05032AP	
C	60		SVX06022AP			SVX06032AP	
D	75		SVX07522AP			SVX07532AP	
D	100	9	SVX10022AP		9	SVX10032AP	

① Enclosure dimensions listed on Pages 77 – 82.

② Includes drive, Local/Remote Keypad and enclosure.

Table 110. 230V Pump Panel Style (Single-Phase)

Enclosure Size ③	hp	NEMA Type 12			NEMA Type 3R		
		Frame Size	Base Catalog Number ④	Price U.S. \$ ④	Frame Size	Base Catalog Number ④	Price U.S. \$ ④
A	3/4	4	SVXF072JBP		4	SVXF073JBP	
A	1		SVX0012JBP			SVX0013JBP	
A	2	5	SVX0022JBP		5	SVX0023JBP	
A	3		SVX0032JBP			SVX0033JBP	
A	5		SVX0052JBP			SVX0053JBP	
A	7-1/2	6	SVX0072JBP		6	SVX0073JBP	
A	10		SVX0102JBP			SVX0103JBP	
B	15	7	SVX0152JBP		7	SVX0153JBP	
B	20		SVX0202JAP			SVX0203JAP	
C	25	8	SVX0252JAP		8	SVX0253JAP	
C	30		SVX0302JAP			SVX0303JAP	
C	40		SVX0402JAP			SVX0403JAP	

③ Enclosure dimensions listed on Pages 77 – 82.

④ Includes drive, Local/Remote Keypad and enclosure.

Table 111. 230V Brake Chopper Adder ⑤

I _H hp	Adder U.S. \$	I _L hp	Adder U.S. \$
	NEMA Type 12/3R		NEMA Type 12/3R
3/4		—	
1		1	
1-1/2		1-1/2	
2		2	
3		3	
5		5	
7-1/2		7-1/2	
10		10	
15		15	
20		20	
25		25	
30		30	
40		40	
50		50	
60		60	
75		75	
100		100	

⑤ External dynamic braking resistors not included. Consult factory.

VFD Pump Panels

Table 112. 230V Control Options

Catalog Number Suffix 	Door-Mounted Speed Potentiometer	Door-Mounted Speed Potentiometer with HOA Selector Switch	Manual/Auto Reference Switch (22 mm)	Start & Stop Pushbuttons (22 mm)
K1		K2	K5	K6
hp	Adder U.S. \$	Adder U.S. \$	Adder U.S. \$	Adder U.S. \$
3/4 – 100				

Table 113. 230V Light Options

Catalog Number Suffix 	Power On/Fault Pilot Lights (22 mm)	Green Stop Light (22 mm)	Red Run Light (22 mm)	Misc. Light (22 mm)	PTT Light (22 mm)	Adder for LED Each
L1		LD	LE	LU	LW	LY
hp	Adder U.S. \$	Adder U.S. \$	Adder U.S. \$	Adder U.S. \$	Adder U.S. \$	Adder U.S. \$
3/4 – 100						

Table 114. 230V Enclosure Options

Catalog Number Suffix 	Floor Stand 22" (558.8 mm)	Space Heater w/out CPT	Space Heater w/CPT	Socket Type Control Relay	On-Delay Timer	Off-Delay Timer
S5		S9	SA	SB	SE	SF
Enclosure Size	Adder U.S. \$	Adder U.S. \$	Adder U.S. \$	Adder U.S. \$	Adder U.S. \$	Adder U.S. \$
A						
B						
C						
D						

Table 115. 230V Power Options



Catalog Number Suffix 	Input					Output
	Two Auxiliary Contacts Installed	Input Disconnect (HMCP) 100 kAIC	Input Line Fuses 200 kAIC	Input Power Surge Protection	TVSS Transient Voltage Surge Suppressor	Output Contactor
	K9	P1	P3	P7	P8	PE
hp	Adder U.S. \$	Adder U.S. \$	Adder U.S. \$	Adder U.S. \$	Adder U.S. \$	Adder U.S. \$
3/4 – 5						
7-1/2 – 10						
15						
20 – 25						
30 – 40						
50						
60 – 75						
100						

Table 116. 230V Bypass Options ^①

Catalog Number Suffix 	Bypass Pilot Lights for RA Option	Manual HOA Bypass Controller
L2 ^②		RA ^②
hp	Adder U.S. \$	Adder U.S. \$
3/4 – 10		
15		
20 – 25		
30 – 40		
50		
60 – 75		
100		

^① See Page 68 for details.

^② Bypass options applicable only in the Pump Panel three-phase design.

480V Drives

Table 117. 480V Pump Panel Style (Three-Phase)

Enclosure Size ①	hp	NEMA Type 12			NEMA Type 3R		
		Frame Size	Base Catalog Number ②	Price U.S. \$ ②	Frame Size	Base Catalog Number ②	Price U.S. \$ ②
480V High Overload Drive and Enclosure							
A	1	4	SVX00124EP		4	SVX00134EP	
A	1-1/2		SVXF1524EP			SVXF1534EP	
A	2		SVX00224EP			SVX00234EP	
A	3		SVX00324EP			SVX00334EP	
A	5		SVX00524EP			SVX00534EP	
A	7-1/2	5	SVX00724EP		5	SVX00734EP	
A	10		SVX01024EP			SVX01034EP	
A	15		SVX01524EP			SVX01534EP	
A	20	6	SVX02024EP		6	SVX02034EP	
A	25		SVX02524EP			SVX02534EP	
B	30		SVX03024EP			SVX03034EP	
B	40	7	SVX04024DP		7	SVX04034DP	
B	50		SVX05024DP			SVX05034DP	
B	60		SVX06024DP			SVX06034DP	
C	75	8	SVX07524DP		8	SVX07534DP	
C	100		SVX10024DP			SVX10034DP	
C	125		SVX12524DP			SVX12534DP	
D	150	9	SVX15024DP		9	SVX15034DP	
D	200		SVX20024DP			SVX20034DP	
TBD	250	10	SVX25024DP		10	SVX25034DP	
TBD	300		SVX30024DP			SVX30034DP	
TBD	350		SVX35024DP			SVX35034DP	

480V Low Overload Drive and Enclosure

A	1-1/2	4	SVXF1524BP		4	SVXF1534BP	
A	2		SVX00224BP			SVX00234BP	
A	3		SVX00324BP			SVX00334BP	
A	5		SVX00524BP			SVX00534BP	
A	7-1/2		SVX00724BP			SVX00734BP	
A	10	5	SVX01024BP		5	SVX01034BP	
A	15		SVX01524BP			SVX01534BP	
A	20		SVX02024BP			SVX02034BP	
A	25	6	SVX02524BP		6	SVX02534BP	
A	30		SVX03024BP			SVX03034BP	
B	40		SVX04024BP			SVX04034BP	
B	50	7	SVX05024AP		7	SVX05034AP	
B	60		SVX06024AP			SVX06034AP	
B	75		SVX07524AP			SVX07534AP	
C	100	8	SVX10024AP		8	SVX10034AP	
C	125		SVX12524AP			SVX12534AP	
C	150		SVX15024AP			SVX15034AP	
D	200	9	SVX20024AP		9	SVX20034AP	
D	250		SVX25024AP			SVX25034AP	
TBD	300	10	SVX30024AP		10	SVX30034AP	
TBD	400		SVX40024AP			SVX40034AP	

① Enclosure dimensions listed on Pages 77 – 82.

② Includes drive, Local/Remote keypad and enclosure.

Table 118. 480V Pump Panel Style (Single-Phase)

Enclosure Size ③	hp	NEMA Type 12			NEMA Type 3R		
		Frame Size	Base Catalog Number ④	Price U.S. \$ ④	Frame Size	Base Catalog Number ④	Price U.S. \$ ④
480V Low Overload Drive and Enclosure							
A	3/4	4	SVXF072KBP		4	SVXF073KBP	
A	1		SVX0012KBP			SVX0013KBP	
A	2		SVX0022KBP			SVX0023KBP	
A	3		SVX0032KBP			SVX0033KBP	
A	5	5	SVX0052KBP		5	SVX0053KBP	
A	7-1/2		SVX0072KBP			SVX0073KBP	
A	10		SVX0102KBP			SVX0103KBP	
A	15	6	SVX0152KBP		6	SVX0153KBP	
A	20		SVX0202KBP			SVX0203KBP	
B	25	7	SVX0252KAP		7	SVX0253KAP	
B	30		SVX0302KAP			SVX0303KAP	
C	40	8	SVX0402KAP		8	SVX0403KAP	
C	50		SVX0502KAP			SVX0503KAP	
C	60		SVX0602KAP			SVX0603KAP	

③ Enclosure dimensions listed on Pages 77 – 82.

④ Includes drive, Local/Remote keypad and enclosure.

Table 119. 480V Brake Chopper Adder ⑤

I _H hp	Adder U.S. \$	I _L hp	Adder U.S. \$
	NEMA Type 12/3R		NEMA Type 12/3R
1		—	
1-1/2		1-1/2	
2		2	
3		3	
5		5	
7-1/2		7-1/2	
10		10	
15		15	
20		20	
25		25	
30		30	
40		40	
50		50	
60		60	
75		75	
100		100	
125		125	
150		150	
200		200	
250		250	
300		300	
350		350	
400		400	

⑤ External dynamic braking resistors not included. Consult factory.

VFD Pump Panels

Table 120. 480V Control Options

Catalog Number Suffix	Door-Mounted Speed Potentiometer	Door-Mounted Speed Potentiometer with HOA Selector Switch	Manual/Auto Reference Switch (22 mm)	Start & Stop Pushbuttons (22 mm)
K1		K2	K5	K6
hp	Adder U.S. \$	Adder U.S. \$	Adder U.S. \$	Adder U.S. \$
3/4 - 100				

Table 121. 480V Light Options

Catalog Number Suffix	Power On/Fault Pilot Lights (22 mm)	Green Stop Light (22 mm)	Red Run Light (22 mm)	Misc. Light (22 mm)	PTT Light (22 mm)	Adder for LED Each
L1		LD	LE	LU	LW	LY
hp	Adder U.S. \$	Adder U.S. \$	Adder U.S. \$	Adder U.S. \$	Adder U.S. \$	Adder U.S. \$
3/4 - 100						

Table 122. 480V Enclosure Options

Catalog Number Suffix	Floor Stand 22" (558.8 mm)	Space Heater w/out CPT	Space Heater w/CPT	Socket Type Control Relay	On-Delay Timer	Off-Delay Timer
S5		S9	SA	SB	SE	SF
Enclosure Size	Adder U.S. \$	Adder U.S. \$	Adder U.S. \$	Adder U.S. \$	Adder U.S. \$	Adder U.S. \$
A						
B						
C						
D						

Table 123. 480V Power Options

Catalog Number Suffix	Input					Output
	Two Auxiliary Contacts Installed	Input Disconnect (HMCP) 100 kAIC	Input Line Fuses 200 kAIC	Input Power Surge Protection	TVSS Transient Voltage Surge Suppressor	Output Contactor
K9		P1	P3	P7	P8	PE
hp	Adder U.S. \$	Adder U.S. \$	Adder U.S. \$	Adder U.S. \$	Adder U.S. \$	Adder U.S. \$
1 - 10						
15 - 20						
25 - 30						
40 - 50						
60 - 75						
100						
125 - 150						
200						
250						
300 - 350						
400						

Table 124. 480V Bypass Options

Catalog Number Suffix	Bypass Pilot Lights for RA Option	Manual HOA Bypass Controller
L2		RA
hp	Adder U.S. \$	Adder U.S. \$
1 - 20		
25		
30		
40 - 50		
60 - 75		
100		
125 - 150		
200		
250 - 350		
400		

① See Page 68 for details.

② Bypass options applicable only in the Pump Panel three-phase design.

June 2006

VFD Pump Panels

Dimensions

Enclosure Box A NEMA Type 12

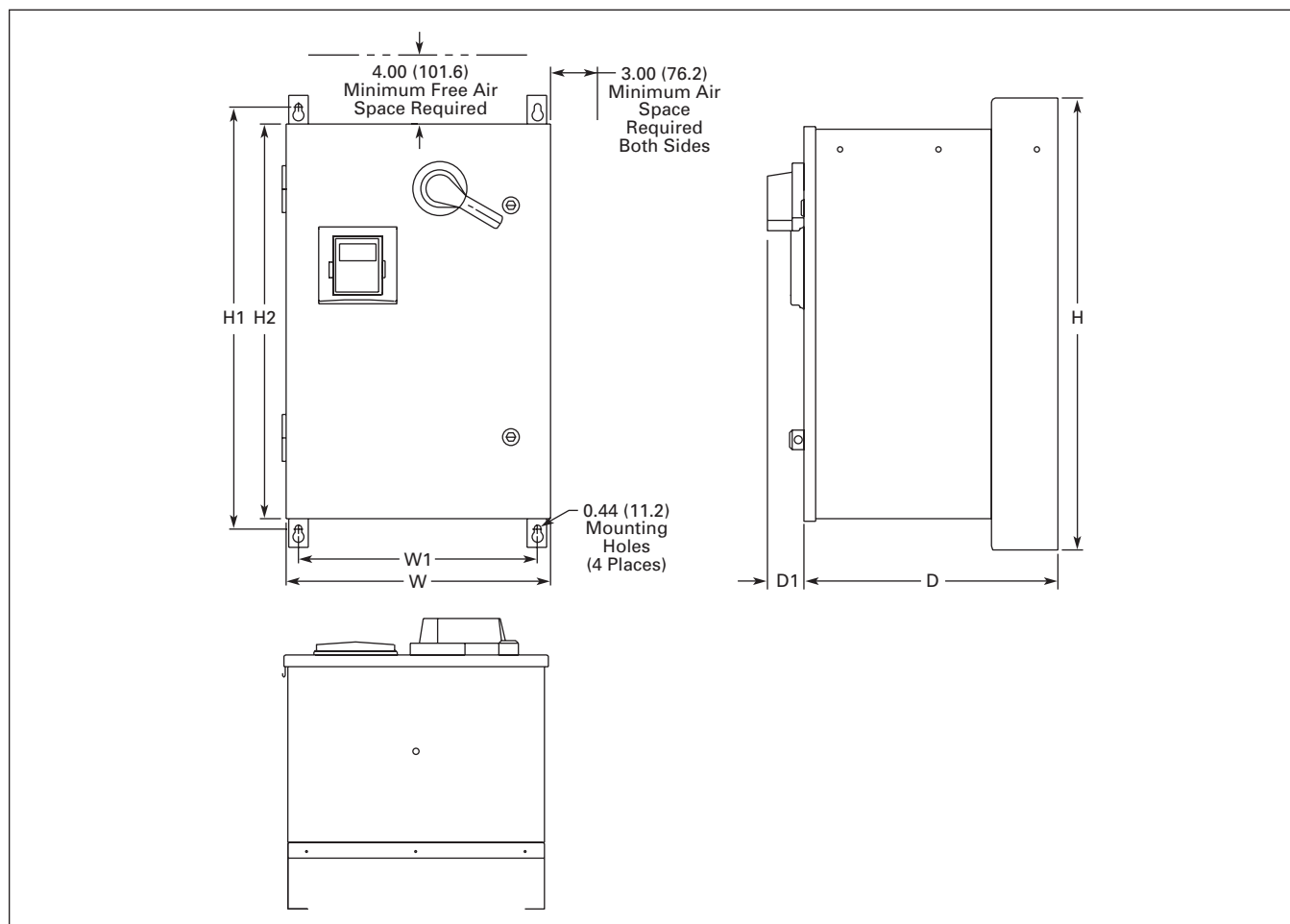

Figure 35. NEMA Type 12 SVX9000 Pump Application Drive Dimensions

Table 125. NEMA Type 12 SVX9000 Pump Application Drive Dimensions

Voltage AC	hp (I _H)	hp (I _L)	Approximate Dimensions in Inches (mm)							Approx. Weight Lbs. (kg)	Approx. Ship Weight Lbs. (kg)
			H	H1	H2	W	W1	D	D1		
Three-Phase											
208V	3/4 – 10	1 – 15	29.00 (736.6)	27.00 (685.8)	25.35 (643.9)	16.92 (429.8)	15.30 (388.6)	16.26 (413.0)	2.34 (59.4)	120 (54)	160 (73)
230V	3/4 – 10	1 – 15									
480V	1 – 25	1 – 30									
Single-Phase											
230V	—	3/4 – 10	29.00 (736.6)	27.00 (685.8)	25.35 (643.9)	16.92 (429.8)	15.30 (388.6)	16.26 (413.0)	2.34 (59.4)	120 (54)	160 (73)
480V	—	3/4 – 20									

VFD Pump Panels

Enclosure Box B NEMA Type 12

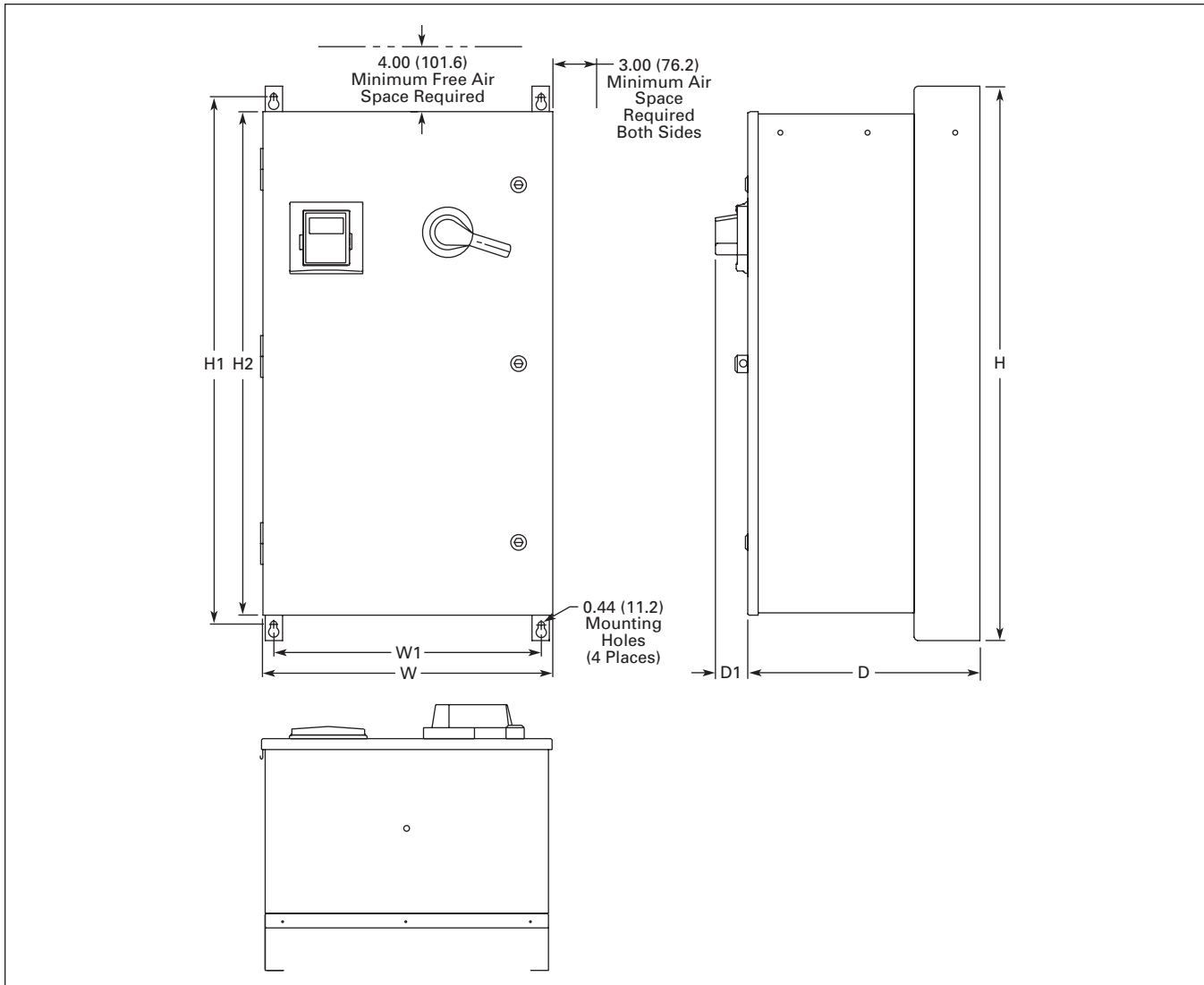

Figure 36. NEMA Type 12 SVX9000 Pump Application Drive Dimensions

Table 126. NEMA Type 12 SVX9000 Pump Application Drive Dimensions

Voltage AC	hp (I _H)	hp (I _L)	Approximate Dimensions in Inches (mm)							Approx. Weight Lbs. (kg)	Approx. Ship Weight Lbs. (kg)
			H	H1	H2	W	W1	D	D1		
Three-Phase											
208V	15 – 25	20 – 30	40.00	38.00	36.35	20.92	19.30	16.76	2.34	185	229
230V	15 – 25	20 – 30	(1016.0)	(965.2)	(923.3)	(531.4)	(490.2)	(425.7)	(59.4)	(84)	(104)
480V	30 – 60	40 – 75									
Single-Phase											
230V	—	15 – 20	40.00	38.00	36.35	20.92	19.30	16.76	2.34	185	229
480V	—	25 – 30	(1016.0)	(965.2)	(923.3)	(531.4)	(490.2)	(425.7)	(59.4)	(84)	(104)

June 2006

VFD Pump Panels

Enclosure Box C NEMA Type 12

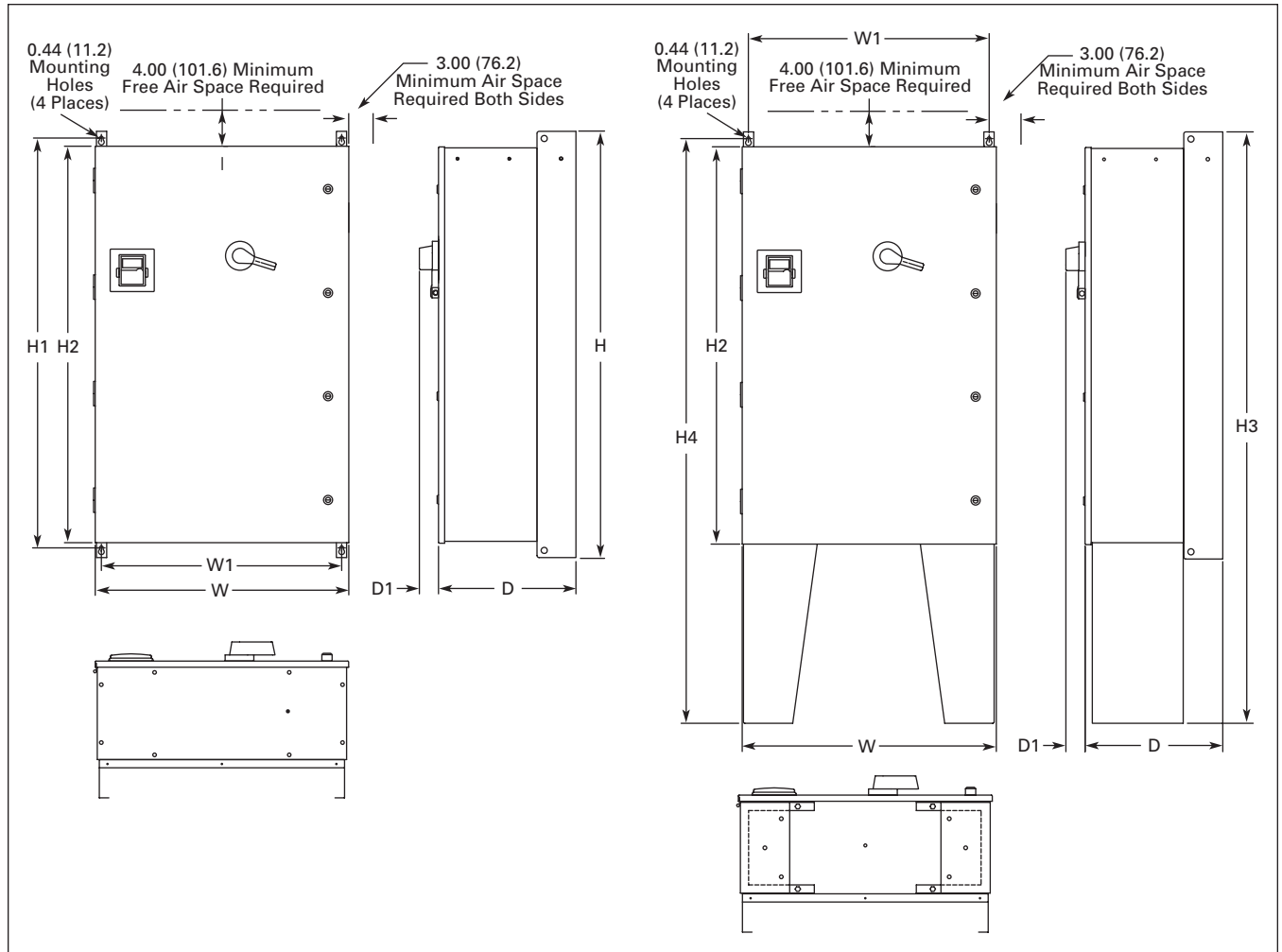

Figure 37. NEMA Type 12 SVX9000 Pump Application Drive Dimensions

Table 127. NEMA Type 12 SVX9000 Pump Application Drive Dimensions

Voltage AC	hp (I _H)	hp (I _L)	Approximate Dimensions in Inches (mm)									Approx. Ship Weight Lbs. (kg)
			H	H1	H2	H3	H4	W	W1	D	D1	
Three-Phase												
208V	30 – 50	40 – 60	52.00	50.00	48.35	72.00	71.19	30.92	29.30	16.78	2.34	①
230V	30 – 50	40 – 60	(1320.8)	(1270.0)	(1228.1)	(1828.8)	(1808.2)	(785.4)	(744.2)	(426.2)	(59.4)	
480V	75 – 125	100 – 150										
Single-Phase												
230V	—	25 – 40	52.00	50.00	48.35	72.00	71.19	30.92	29.30	16.78	2.34	①
480V	—	40 – 60	(1320.8)	(1270.0)	(1228.1)	(1828.8)	(1808.2)	(785.4)	(744.2)	(426.2)	(59.4)	

① Consult factory.

VFD Pump Panels

Enclosure Box A NEMA Type 3R

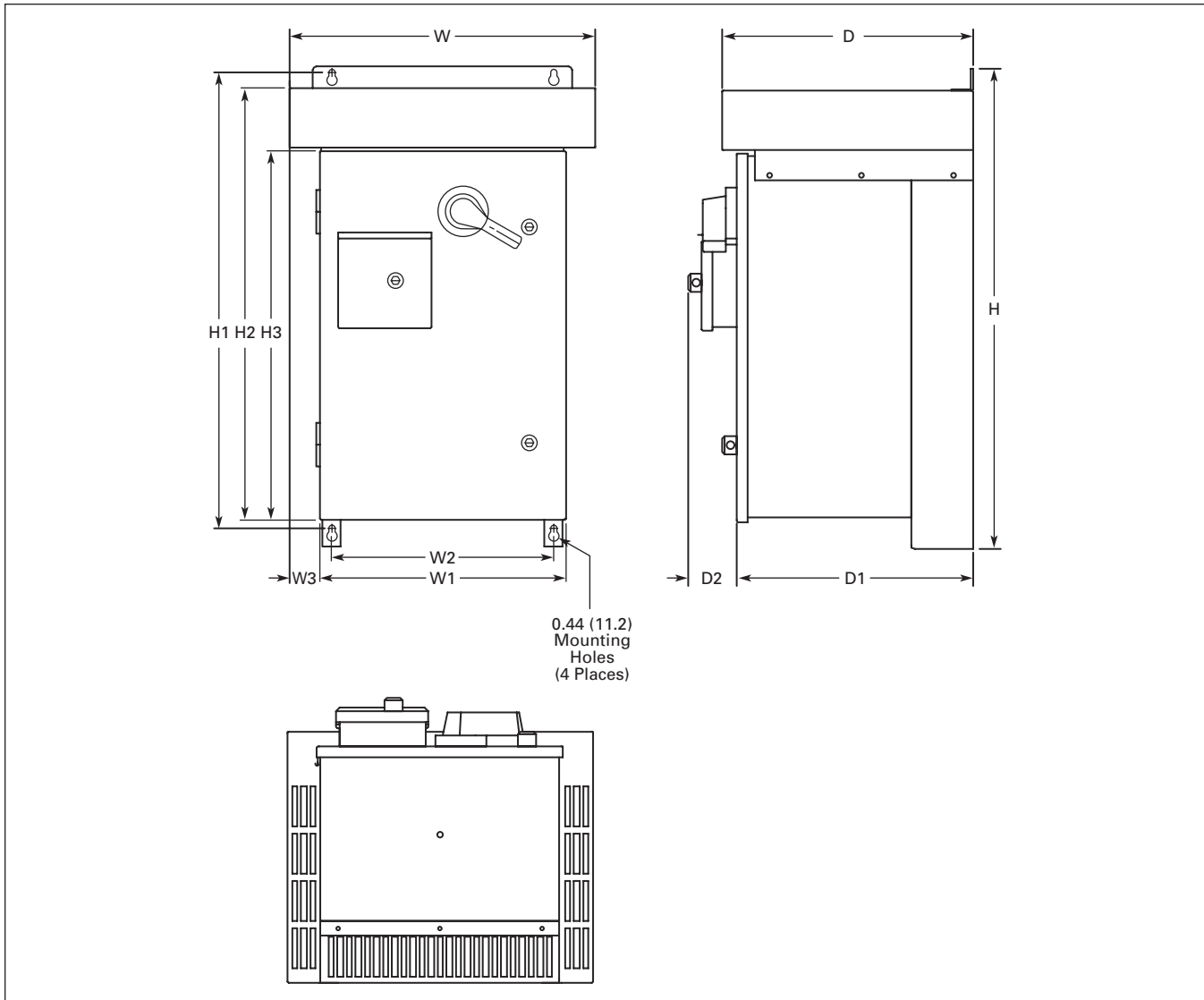

Figure 38. NEMA Type 3R SVX9000 Pump Application Drive Dimensions

Table 128. NEMA Type 3R SVX9000 Pump Application Drive Dimensions

Voltage AC	hp (I _H)	hp (I _L)	Approximate Dimensions in Inches (mm)											Approx. Weight Lbs. (kg)	Approx. Ship Weight Lbs. (kg)	
			H	H1	H2	H3	W	W1	W2	W3	D	D1	D2			
Three-Phase																
208V	3/4 – 10	1 – 15	33.00	31.36	29.67	25.35	21.05	16.92	15.30	2.07	17.24	16.26	3.31	170	215	
230V	3/4 – 10	1 – 15	(838.2)	(796.5)	(753.6)	(643.9)	(534.7)	(429.8)	(388.6)	(52.6)	(437.9)	(413.0)	(84.1)	(77)	(98)	
480V	1 – 25	1 – 30														
Single-Phase																
230V	—	3/4 – 10	33.00	31.36	29.67	25.35	21.05	16.92	15.30	2.07	17.24	16.26	3.31	170	215	
480V	—	3/4 – 20	(838.2)	(796.5)	(753.6)	(643.9)	(534.7)	(429.8)	(388.6)	(52.6)	(437.9)	(413.0)	(84.1)	(77)	(98)	

June 2006

VFD Pump Panels

Enclosure Box B NEMA Type 3R

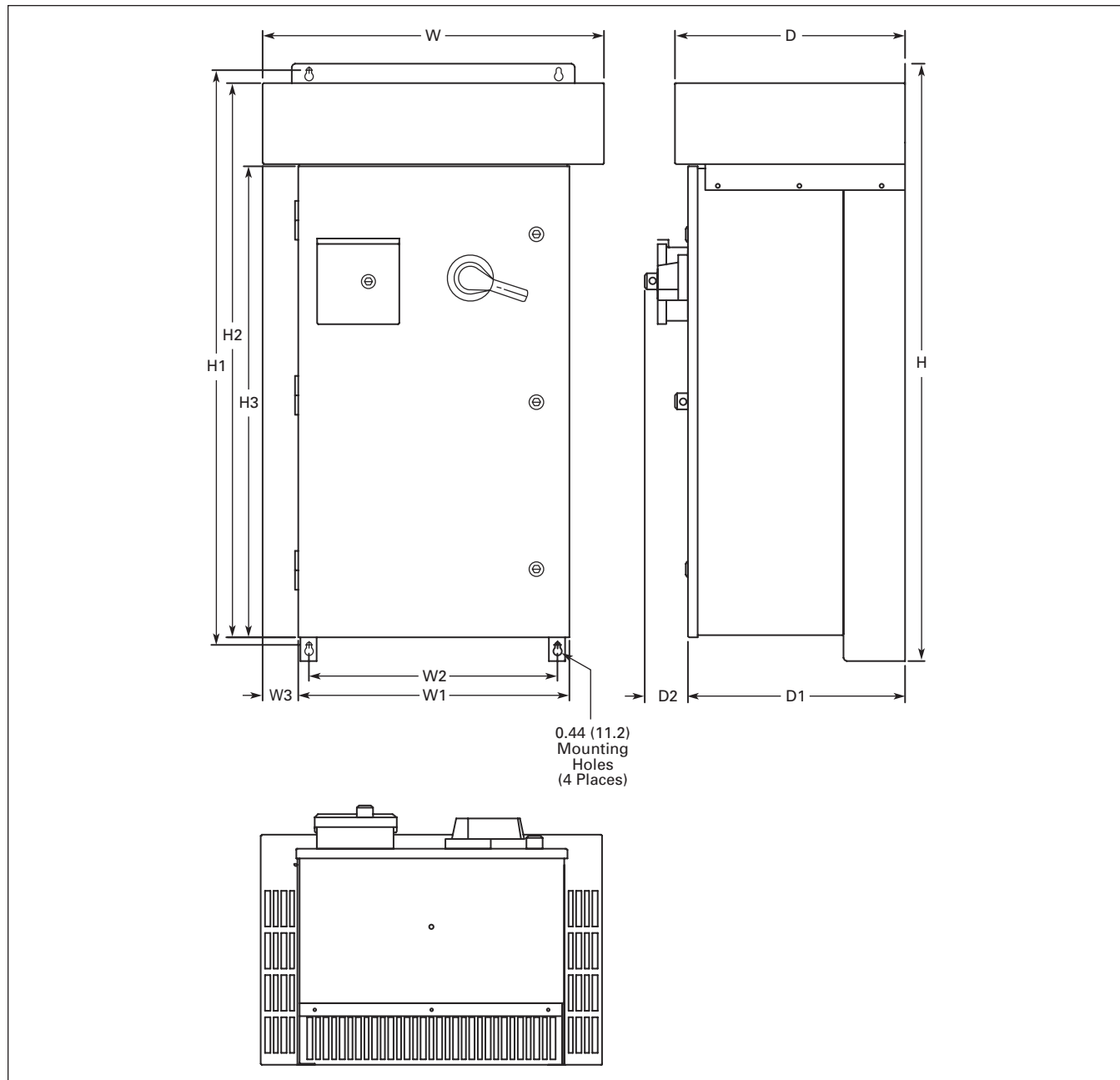

Figure 39. NEMA Type 3R SVX9000 Pump Application Drive Dimensions

Table 129. NEMA Type 3R SVX9000 Pump Application Drive Dimensions

Voltage AC	hp (I _H)	hp (I _L)	Approximate Dimensions in Inches (mm)											Approx. Weight Lbs. (kg)	Approx. Ship Weight Lbs. (kg)
			H	H1	H2	H3	W	W1	W2	W3	D	D1	D2		
Three-Phase															
208V	15 – 25	20 – 30	46.09 (1170.7)	44.45 (1129.0)	42.77 (1086.4)	36.35 (923.3)	26.31 (668.3)	20.92 (531.4)	19.30 (490.2)	2.69 (68.3)	17.74 (450.6)	16.76 (425.7)	3.31 (84.1)	235 (107)	290 (132)
230V	15 – 25	20 – 30													
480V	30 – 60	40 – 75													
Single-Phase															
230V	—	15 – 20	46.09 (1170.7)	44.45 (1129.0)	42.77 (1086.4)	36.35 (923.3)	26.31 (668.3)	20.92 (531.4)	19.30 (490.2)	2.69 (68.3)	17.74 (450.6)	16.76 (425.7)	3.31 (84.1)	235 (107)	290 (132)
480V	—	25 – 30													

VFD Pump Panels

Enclosure Type C NEMA Type 3R

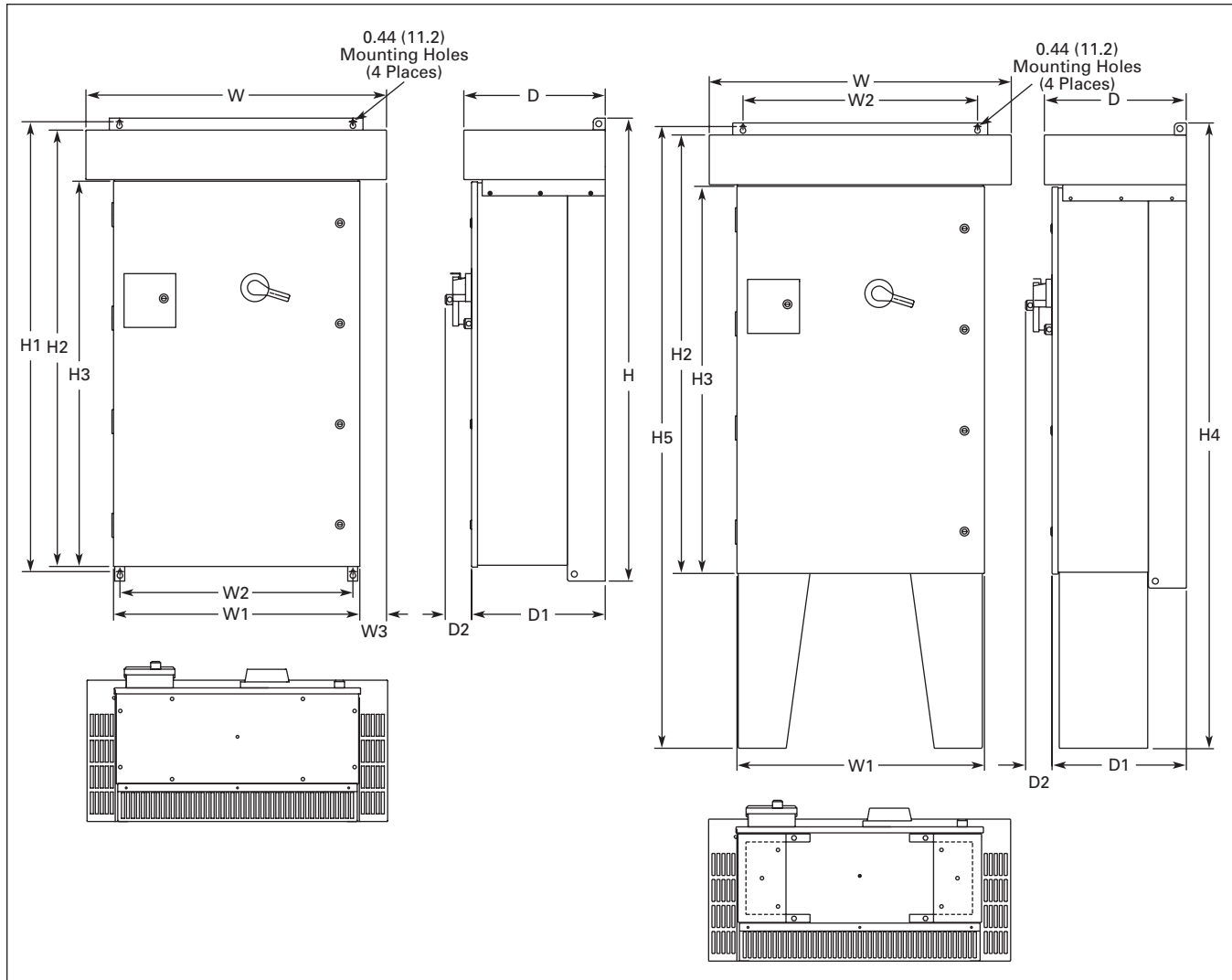

Figure 40. NEMA Type 3R SVX9000 Pump Application Drive Dimensions

Table 130. NEMA Type 3R SVX9000 Pump Application Drive Dimensions

Voltage AC	hp (I _H)	hp (I _L)	Approximate Dimensions in Inches (mm)												Approx. Weight Lbs. (kg)	
			H	H1	H2	H3	H4	H5	W	W1	W2	W3	D	D1		D2
Three-Phase																
208	30 – 50	40 – 60	58.09	56.45	54.77	48.35	78.09	77.64	37.73	30.92	29.30	3.34	17.74	16.77	3.31	①
230	30 – 50	40 – 60	(1475.5)	(1433.8)	(1391.2)	(1228.1)	(1983.5)	(1972.1)	(958.3)	(785.4)	(744.2)	(84.8)	(450.6)	(426.0)	(84.1)	
480	75 – 125	100 – 150														
Single-Phase																
230V	—	25 – 40	58.09	56.45	54.77	48.35	78.09	77.64	37.73	30.92	29.30	3.34	17.74	16.77	3.31	①
480V	—	40 – 60	(1475.5)	(1433.8)	(1391.2)	(1228.1)	(1983.5)	(1972.1)	(958.3)	(785.4)	(744.2)	(84.8)	(450.6)	(426.0)	(84.1)	

① Consult factory.

Wiring Diagrams

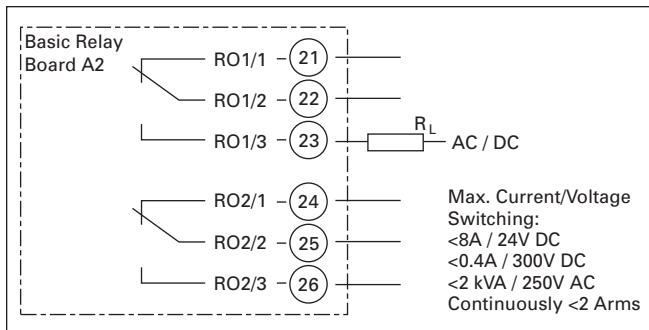

Figure 41. A2 Board Control Wiring

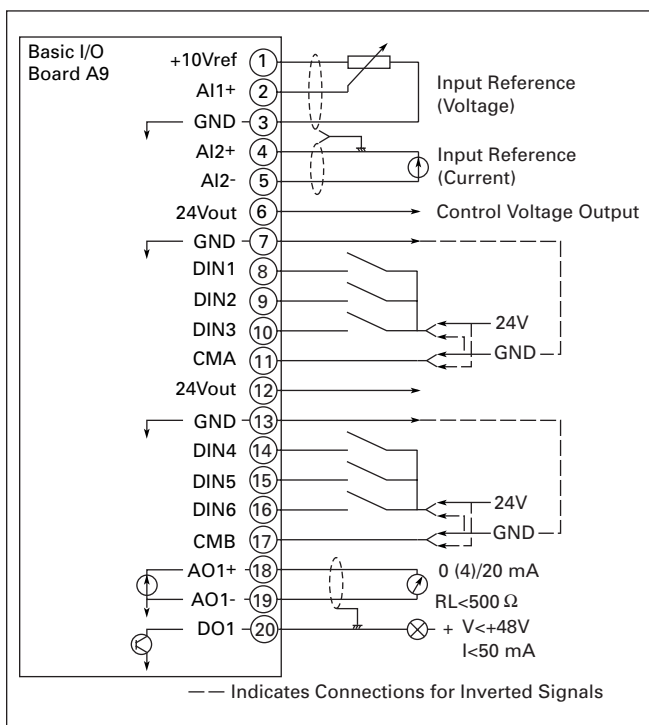

Figure 42. A9 Board Control Wiring

VFD Pump Panels

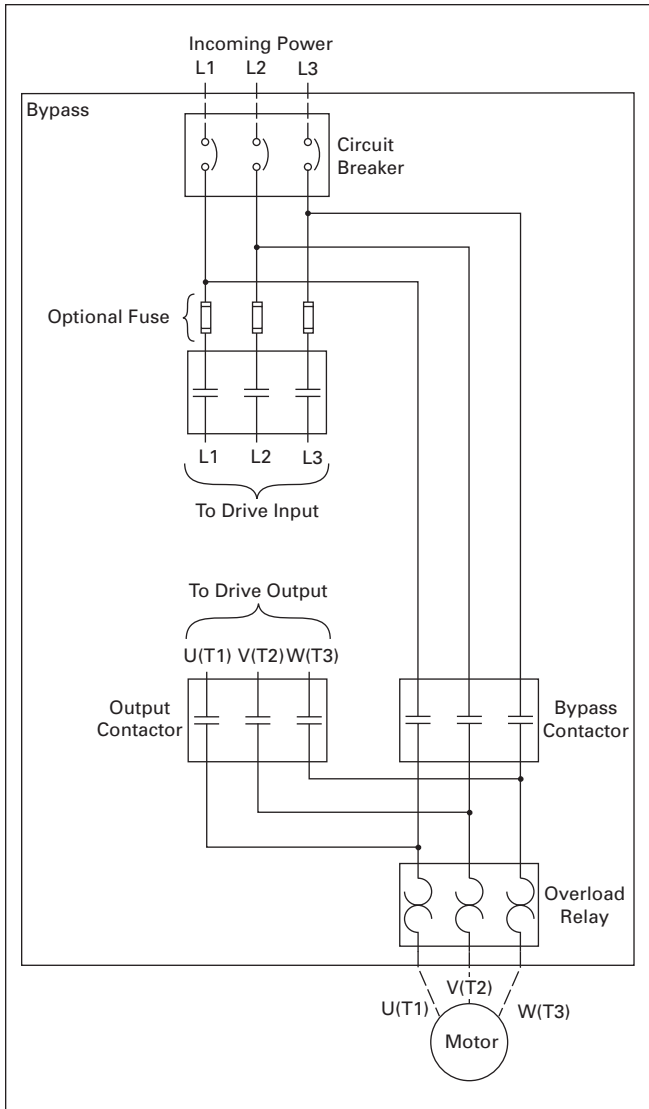

Figure 43. SVX9000 Pump Panel Bypass Power Wiring

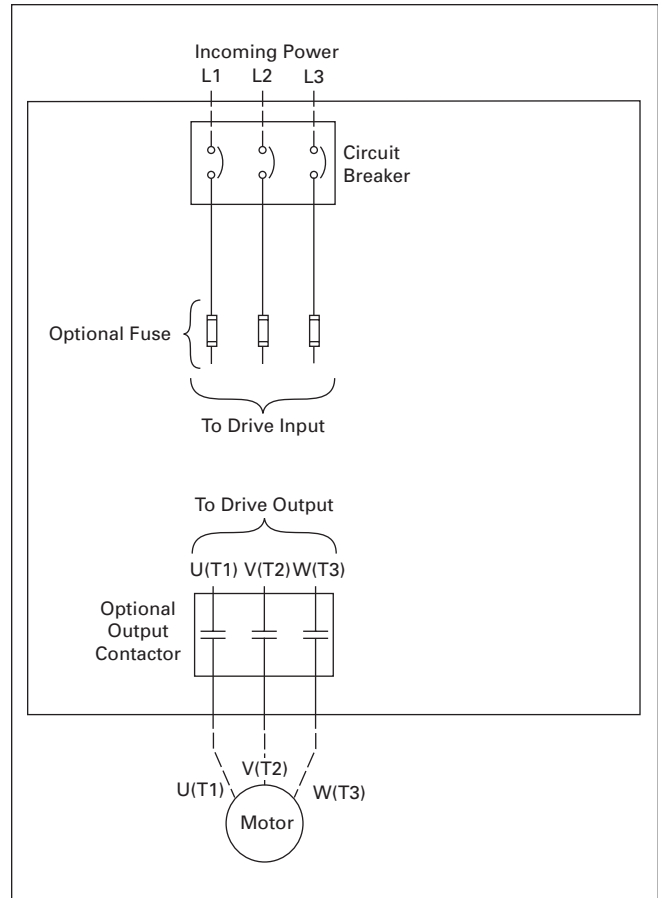

Figure 44. SVX9000 Pump Panel Disconnect Power Wiring

Eaton Electrical Inc.
 1000 Cherrington Parkway
 Moon Township, PA 15108-4312
 USA
 tel: 1-800-525-2000
 www.EatonElectrical.com

© 2006 Eaton Corporation
 All Rights Reserved
 Printed in USA
 Publication No. TB04003002E/CPG
 June 2006