

Product Catalogue | 2006/2007

SASY 60i

valid from Oktober 2006



SASY 60i the consistent, UL-certified solution for power distribution and for switching, controlling and protecting your equipment.

A space-saving design ideal for mechanical and systems engineering.

Metering boards

Compact
Distribution Boxes

Flat Distribution
Boards

Installation
Distribution Boards

Add-on Distribution
Boards

Accessories



MOELLER 

We keep power under control.

Moeller - Customer-focused and Innovative

SASY 60i - now a UL-certified Component

Moeller has accepted the challenge



To stay successful together with our customers in the future as well, it is natural for us to adapt our products to changing realities on the North American market. A lean and yet varied range of products, a high level of flexibility and of course absolute safety - all these attributes are synonyms for Moeller's new SASY 60i busbar system.



New requirements of the UL 508A Standard for Industrial Control Panels result in limitations with regard to the IEC stipulations for current load on busbars: In North America, the current carrying capacity of copper busbars has been fixed at $1.55 \text{ A} / \text{mm}^2$.



For a cross-section area of 300 mm^2 (busbar of $30 \times 10 \text{ mm}$) this means a maximum permissible current of 465 A, while IEC allows a maximum current of 630 A.

With Moeller's new double T-profile bars it is possible to achieve a maximum permissible current of 1116A in accordance with UL stipulations.

Busbar systems are now more frequently designed without fusible cut-outs. So adapters directly and comfortably contact motor protective and power switches up to 630 A on the busbars without drilling.

SASY 60i - The Innovative Busbar System - now UL-508A listed

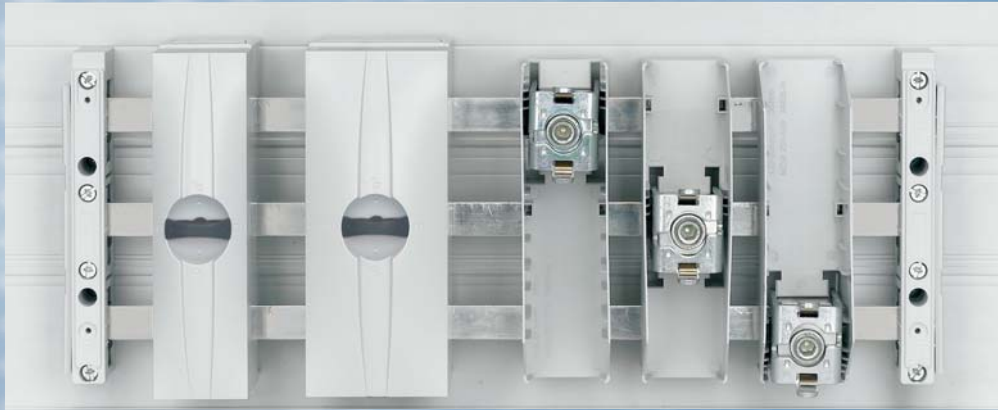

SASY 60i - the Busbar System for the Global Market

Consistent, customer-focused and innovative - this is how Moeller now provides a solution for using busbar systems complying with UL 508A requirements for the North American type of industrial control panels. This kind of space-saving design has established itself especially in the mechanical engineering and systems business.

A crucial aspect of the success we share with our customers was to adapt the 60 mm system to the larger air gaps and longer creepage distances required in North America. And we have successfully managed this technical challenge.

With SASY 60i - in combination with the new generation of motor protection and circuit breakers - Moeller is one of the first suppliers to offer a consistent, UL-certified solution allowing to distribute power and to switch, control and protect equipment at the same time.

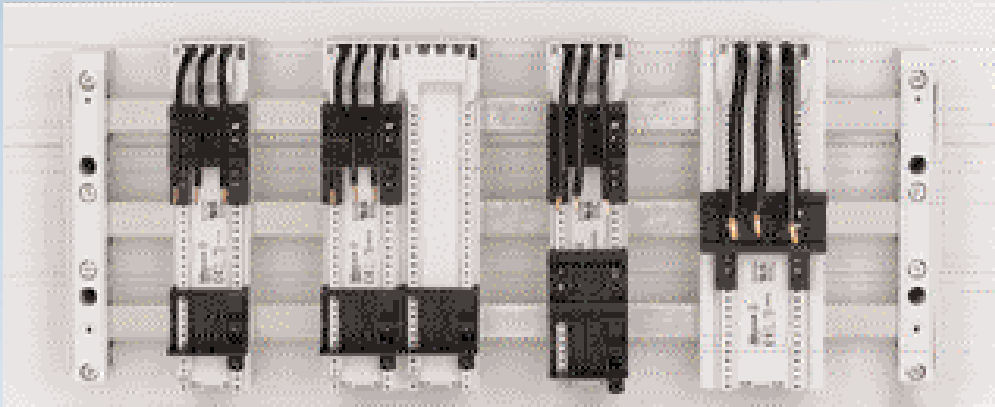

Challenge: Use in compliance with the UL 508A Standard.

Requirements for the North American market are defined in the National Electrical Code (NEC), and Underwriters Laboratories (UL) develops the corresponding standards. Companies can ask Underwriters Laboratories to test and approve their products.

The UL 508A Standard covers the use of components for industrial control equipment. According to this Standard, any equipment for the control of systems and for monitoring and protecting motors belongs to the category of "Industrial Control Panels".

Therefore there are new requirements applicable for voltage gaps in UL 508A tested products. The following criteria need to be considered:

- the air gap must be 1 inch (corresponding to 25.4 mm) and
- the creepage distance must be 2 inches (corresponding to 50.8 mm).

In case any grounded, non-insulated metal parts are used - such as mounting plates - the air gap and the creepage distance must be 1 inch. These distances are much larger than those required in the IEC standard.

For the type of busbar systems commonly used in Europe and frequently exported to North America, especially within the mechanical engineering business, these requirements imply changes in the detail.

End cover for busbar support



Double T-Profile Busbar

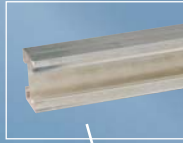

Compartment Section Double-T

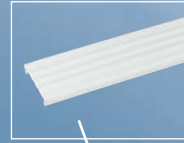

Busbar support Double-T-profile 3-pole



Busbar support Double-T-profile 1-pole



Support for Reserve Section cover



Reserve Section cover



Conductor terminal



Brace terminal



End cover for bus-bar support



IEC busbar support



Terminal plate



Connecting set

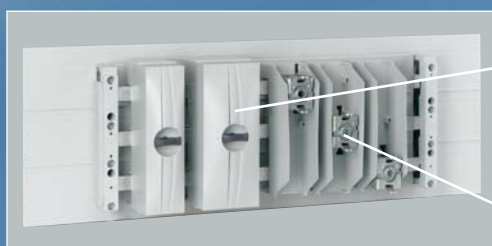

Busbar adaptor
PKZM0

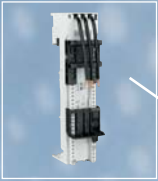

Universal adaptor



Busbar adaptor
PKZM4

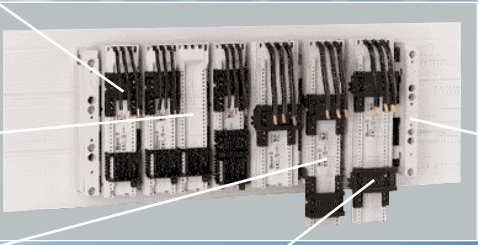

Busbar adaptor
PKZ2



UL busbar support



Busbar adaptor
NZM 1



Busbar adaptor
NZM 2



Busbar adaptor
NZM 3

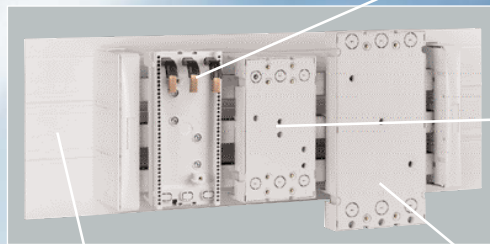

UL base plate

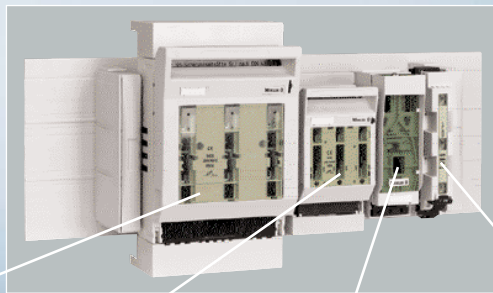

Fuse switch dis-
connector NH1-3



Fuse switch dis-
connector NH00



Fuse switch dis-
connector NH000



Switch disconnector
D02



SASY 60i Busbar System

Table of Contents SASY 60i Busbar System

System up to 630 A for flat busbars	Page 8
System up to 1250, 1600 A for profile busbars	Page 10
Covers for 630, 1250 and 1600 A systems	Page 11
Feeder circuit adapters for 630, 1250 and 1600 A systems	Page 12
Terminals for 630, 1250 and 1600 A systems	Page 13
Lengthwise busbar connections for 630, 1250 and 1600 A systems	Page 16
Busbar adaptors	Page 17
Slide fuse equipment, 3-pole	Page 20
Multi-layer copper band, insulated	Page 23

SASY 60i Busbar System

SASY 60i Busbar System

- Components now also conforming to UL-standards for control systems
- 60 mm spacing between busbars
- 630, 1250 and 1600 A of rated current
- Adapter technology for NZM1 to 3
- Adapter technology for xStart
- Slide fuse equipment

Technical data as of page xx.

VT20106



VT20406

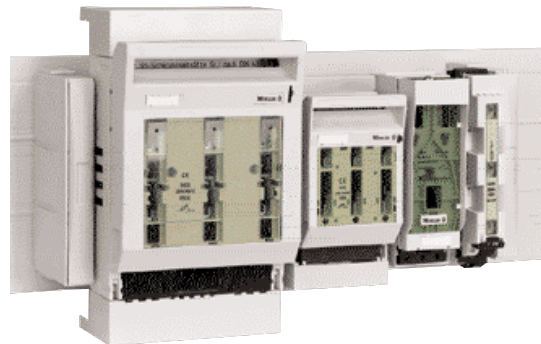







VT20706



VT20806









Systems up to 630 A for Flat Busbars							
Poles Number	Max. Rated-Operating Current Ie (A)	Special Features	Utilisation	Designation	Notes Article No.	Units per Package	
IEC Busbar Support							
 VT12706	3	630	With snap-in slide for adapting to the respective size of the bar	12 x 5/10 15 x 5/10 20 x 5/10 25 x 5/10 30 x 5/10	BBS-3/FL 107066	With pre-drilled holes inside for screw-fixing	10 units
UL Busbar Support							
 VT12806	3	630	With snap-in slide for adapting to the respective size of the bar	12 x 5/10 20 x 5/10 30 x 5/10	BBS-3/FL-NA 107067	With pre-drilled holes inside for screw-fixing	10 units
If used in feeder circuits according to UL 508A up to 600 V, it is necessary use the BBC-BT-NA base plate in addition.							
End Cover							
 VT14006	–	–	–	To cover the busbar ends for BBS-3/FL and BBS-3/FL-NA	ES-BBS-3/FL 107068		10 units
UL Base Plate							
 VT19806	–	–	To be used when the air gap between fully equipped busbar systems and mounting plate is insufficient	Necessary for UL support BBS-3/FL-NA	BBC-BT-NA 107172	1100 mm long	2 units
PE/N Earth/Neutral Busbar Support							
 VT13006	2	630	With snap-in slide for adapting to the respective size of the bar	12 x 5/10 15 x 5/10 20 x 5/10 25 x 5/10 30 x 5/10	BBS-2/FL 107069	can be mounted individually	10 units
 VT17106	1	630	With snap-in slide for adapting to the respective size of the bar	12 x 5/10 15 x 5/10 20 x 5/10 25 x 5/10 30 x 5/10	BBS-1/FL 107161	can be mounted individually	10 units







SASY 60i Busbar System



















	Poles Number	Max. Rated Operating Current Ie (A)	Special Features	Utilisation	Designation Article No.	Notes	Units per Package
Busbar Covers							
VT19706	-	-	-	12 x 5 15 x 5 20 x 5 25 x 5 30 x 5	BBC-FL5 107173	12-30x5 1000 mm long	10 units
VT19406	-	-	-	12 x 10 15 x 10 20 x 10 25 x 10 30 x 10	BBC-FL10 107174	12-30x10 1000 mm long	10 units







Systems up to 1250, 1600 A for Profile Bars							
	Poles Number	Max. Rated Operating Current I _e (A)	Special Features	Utilisation	Designation Article No.	Notes	Units per Package
	3	1600	Suitable as lateral and central support	Double-T-Profile	BBS-3/PR 107162	With pre-drilled holes inside for screw-fixing	3 units
	1	1600	Suitable for setting up a PE or N bar	Double-T-Profile	BBS-1/PR 107165	With pre-drilled holes inside for screw-fixing	10 units
	–	–	–	For the BBS-3/PR support	ES-BBS-3/PR 107164	–	4 units
	–	–	To be used when the air gap between fully equipped busbar systems and mounting plate is insufficient	For UL508A-systems use AKP ... profile terminals	BBC-BT-NA 107172	1100 mm long	2 units
	–	1250 ¹⁾	Tin-plated Cross-section 500 mm ²	For BBS-3/PR and BBS-1/PR supports	CU-BAR-500/T 107166	2400 mm long	1 unit
	–	1600 ¹⁾	Tin-plated Cross-section 720 mm ²	For BBS-3/PR and BBS-1/PR supports	CU-BAR-720/T 107167	2400 mm long	1 unit
	–	–	–	For double-T-profile	BBC-CU-BAR/PR 107175	1000 mm long	5 units

¹⁾ At a busbar temperature of 87.5°C and an ambient temperature of 35°C, please refer to the current load diagram on technic part for further values.





Covers for 630, 1250 and 1600 A Systems				
Utilisation	Designation Article No.	Notes	Units per Package	
	Reserve Section Cover - Modular			
	To cover the front of the 60 mm system	BBC-RCOV1 107178	1100 mm long. To be used with BBC-MRCOV1 support only	2 units
	Support for Reserve Section Cover			
	Suits any thickness of bars	BBC-MRCOV1 107179	To be used with reserve section cover BBC-RCOV1 only	10 units
System Cover - Modular				
	Cover Profile - Front			
	For 3-pole systems	BBC-CS2-F 107180	1100 mm long	1 unit
	Cover Profile - Top/Bottom			
12x5/10 20x5/10 25x5/10 30x5/10	BBC-CS2-T/B 107181	1100 mm long	2 units	
	Support Set for Cover Profile			
	For 3-pole systems	BBC-MCS2 107182	1 set includes a right and left side support	1 unit
	Compartment Section Double-T			
	For 3-pole systems with BBS-3/PR	BBC-CS48/PR 107176	48 mm high 2400 mm long To be fixed at the (profile) bar support	1 unit
	For 3-pole systems with BBS-3/PR	BBC-CS76/PR 107177	76 mm high 2400 mm long To be fixed at the (profile) bar support	1 unit

Feeder Circuit Adapters for 630, 1250 and 1600 A Systems





	Poles Number	Max. Rated Operating Current Ie (A)	Type of Conductor ¹⁾	Utilisation	Designation Article No.	Notes	Units per Package
	3	300	6 - 50 mm ² AWG 10 - AWG 2/0.	12x5/10 15x5/10 20x5/10 25x5/10 30x5/10	BBA-TP3/50 107183	54 mm wide. Terminals can be removed for connecting non-cut conductors. Looping them through is possible.	1 unit
			    6X9X0.8 Double-T-Profile	Double-T-Profile			
	3	440	35 - 120 mm ² AWG 2 - MCM 250.	12x5/10 15x5/10 20x5/10 25x5/10 30x5/10	BBA-TP3/120 107184	81 mm wide. Terminals can be removed for connecting non-cut conductors. Looping them through is possible.	1 unit
	3 x 1	560	120 - 300 mm ² MCM300 - MCM600.	20x5/10 25x5/10 30x5/10	BBA-TP3/300 107185	180 - 240 mm wide. Clearance between poles can be adjusted as required. To be fixed directly on top of the busbar terminal. Incl. cover cap in flexible width. 1 set includes 3 pole elements. Looping through is possible.	1 unit
			    	Double-T-Profile			
	3 x 1	800	Up to  10X32X1	20x5/10 25x5/10 30x5/10	BBA-TP3/CU-BAND 107186	180 - 240 mm wide. Clearance between poles can be adjusted as required. To be fixed directly on top of the busbar terminal. Incl. cover cap in flexible width. 1 set includes 3 pole elements. Looping through is possible.	1 unit
			 Double-T-Profile	Double-T-Profile			

¹⁾  Round conductor, single-wired
 Round conductor, fine-wired with expertly pressed wire end ferrule
 Round conductor, multi-wired
 Sector conductor, single-wired
 Sector conductor, multi-wired
 Cu-Band
 Cu-Bar





Terminals for 630, 1250 and 1600 A Systems

	Max. Rated Operating Current I _e (A)	Type of ¹⁾	Special Features Conductor	Utilisation	Designation	Notes Article No.	Units per Package
Brace Terminals							
	500	95 - 185mm ² , AWG3/0 - MCM350. ⊗ directly terminated, ⊙ ◊	Connection method to busbars without drilling	20x5/10 25x5/10 30x5/10 Double-T-Profile	AKS185 107195	Contacting of wire and busbar via a cable bed	6 units
	600	150 - 300mm ² , MCM300 - MCM600. ⊗ directly terminated, ⊙ ◊	Connection method to busbars without drilling	20x5/10 25x5/10 30x5/10 Double-T-Profile	AKS300 107196	Contacting of wire and busbar via a cable bed	3 units
	800	⊞ 3x20x1 bis 2x(10x32x1)	Connection method to busbars without drilling	20x5/10 25x5/10 30x5/10 Double-T-Profile	AKS-CU-BAND 107197	Contacting of wire and busbar via a contacting block	3 units
Profile Terminals ²⁾							
	1600	800 mm ² , Termination space 41 x 20-42 ■ ⊞	Connection method to busbars without drilling	Double-T- Profile	AKP800 107198	In case of parallel connection of multi-layer copper bars, please place spacers in between	3 units
	1600	1000 mm ² , Termination space 51 x 20-42 ■ ⊞	Connection method to busbars without drilling	Double-T- Profile	AKP1000 107199	In case of parallel connection of two multi-layer copper bars, please place spacers in between	3 units
¹⁾ <ul style="list-style-type: none"> ○ Round conductor, single-wired ⊗ Round conductor, fine-wired with expertly pressed wire end ferrule ⊙ Round conductor, multi-wired ◊ Sector conductor, single-wired ◊ Sector conductor, multi-wired ⊞ Cu-Band ■ Cu-bar 							
²⁾ For a UL508A system with profile terminals you need to use the UL base plate BBC-BT-NA and the busbar cover BBC-CU-BAR/PR.							





Terminals for 630, 1250 and 1600 A Systems

	Max. Rated Operating Current I _e (A)	Type of Conductor ¹⁾	Special Features	Utilisation	Designation Article No.	Units per Package
Universal Conductor Terminal 5 mm						
	180	1.5 - 16mm ² , AWG 14 - AWG 6. ⊙ directly terminated, ○ ⊕ ≡ 8x6x0.5	With integrated retaining spring, impossible to lose the terminal screw	All flat busbars of a thickness of 5 mm	AKU16/5 107187	100 units
	270	4 - 35mm ² , AWG 10 - AWG 2. ⊕ directly terminated, ○ ⊕ ≡ 3x9x0.8 or 6x9x0.8	With integrated retaining spring, impossible to lose the terminal screw	All flat busbars of a thickness of 5 mm	AKU35/5 107188	50 units
	400	16 - 70mm ² , AWG 4 - AWG 2/0. ⊕ directly terminated, ⊕ ≡ 2x(3x9x0.8) or 6x9x0.8	With integrated retaining spring, impossible to lose the terminal screw	All flat busbars of a thickness of 5 mm	AKU70/5 107189	25 units
	440	16 - 120mm ² , AWG 4 - MCM 250. ⊕ directly terminated, ⊕ ≡ 4x16x0.8 or 6x16x0.8 or 10x16x0.8	With integrated retaining spring, impossible to lose the terminal screw	All flat busbars of a thickness of 5 mm	AKU120/5 107190	25 units
¹⁾ <ul style="list-style-type: none"> ○ Round conductor, single-wired ⊕ Round conductor, fine-wired with expertly pressed wire end ferrule ⊕ Round conductor, multi-wired ◇ Sector conductor, single-wired ◇ Sector conductor, multi-wired ≡ Cu-Band ■ Cu-Bar 						





Terminals for 630, 1250 and 1600 A Systems

	Max. Rated Operating Current I _e (A)	Type of Conductor ¹⁾	Special Features	Utilisation	Designation Article No.	Units per Package
	180	1.5 - 16mm ² , AWG 14 - AWG 6. ⊙ directly terminated, ○ ⊕ ≡ 8x6x0.5	With integrated retaining spring, impossible to lose the terminal screw	All flat busbars of a thickness of 10 mm	AKU16/10 107191	100 units
	270	4 - 35mm ² , AWG 10 - AWG 2. ⊙ directly terminated, ○ ⊕ ≡ 3x9x0.8 or 6x9x0.8	With integrated retaining spring, impossible to lose the terminal screw	All flat busbars of a thickness of 10 mm	AKU35/10 107192	50 units
	400	16 - 70mm ² , AWG 4 - AWG 2/0. ⊙ directly terminated, ⊕ ≡ 2x(3x9x0.8) or 6x9x0.8	With integrated retaining spring, impossible to lose the terminal screw	All flat busbars of a thickness of 10 mm, double-T-profile	AKU70/10 107193	25 units
	440	16 - 120mm ² , AWG 4 - MCM 250. ⊙ directly terminated, ⊕ ≡ 4x16x0.8 or 6x16x0.8 or 10x16x0.8	With integrated retaining spring, impossible to lose the terminal screw	All flat busbars of a thickness of 10 mm, double-T-profile	AKU120/10 107194	25 units
¹⁾ ○ Round conductor, single-wired ⊙ Round conductor, fine-wired with expertly pressed wire end ferrule ⊕ Round conductor, multi-wired ◊ Sector conductor, single-wired ⊖ Sector conductor, multi-wired ≡ Cu-Band ■ Cu-Bar						

Lengthwise Bar Connections for 630, 1250 and 1600 A Systems

	Max. Rated Operating Current I _e (A)	Length (mm)	Special Features	Utilisation	Designation Article No.	Notes	Units per Package
Busbar Connecting Terminals							
	630	150	For identically shaped, flat copper bars	12 x 5/10 15 x 5/10 20 x 5/10	BBT-CU12-20X5/10-150 107200	Spacing between systems up to 110 mm	3 units
	630	95	For identically shaped, flat copper bars	20 x 5/10 25 x 5/10 30 x 5/10	BBT-CU20-30X5/10-95 107201	Spacing between systems 50 - 60 mm. Max. permissible mis-alignment of bars is 5 mm	3 units
	630	150	For identically shaped, flat copper bars	20 x 5/10 25 x 5/10 30 x 5/10	BBT-CU20-30X5/10-150 107202	Spacing between systems 100 - 110 mm. Max. permissible mis-alignment of bars is 5 mm	3 units
	1600	50	For different and identical types of double-T-profile bars	Double-T-profile	BBT-CU-BAR500/720-50 107203	Spacing between systems 9 - 20 mm. Max. permissible mis-alignment of bars is 2 mm	6 units
	1600	150	For different and identical types of double-T-profile bars	Double-T-profile	BBT-CU-BAR500/720-150 107204	Spacing between systems 100 - 110 mm. Max. permissible mis-alignment of bars is 5 mm	3 units

NZM Busbar Adapter, 3-pole ¹⁾, for Copper Bars 12 - 30 x 5/10, Double-T-Profile

	Max. Rated Oper. Current I _e (A)	Rated Operating Voltage U _e (V)	Adapter Width (mm)	Adapter Length (mm)	Special Features	Utili- sation	Designation Article No.	Notes	Units per Package
 <p>VT16206</p>	160	690	90	200	For connecting to the system at the top through fixed connection bars included in the scope of delivery ²⁾	NZM1 PN1 N1 NS1	NZM1-XAD160 104554	For switches with standard connection frame-type terminals. To be snapped onto the busbar by means of a combi-base.	1 unit
 <p>VT17706</p>	250	690	106	190	For connecting to the system at the top/bottom through a tube-type of connection at the rear. Tube included in the scope of delivery.	NZM2 PN2 N2 NS2	NZM2-XAD250 104555	Use only in combination with the auxiliary type (+)NZM2-XKR4. To be screwed onto the busbar by means of a claw-type of clamp.	1 unit
 <p>VT17606</p>	550	690	140	270	For connecting to the system at the top through a tube-type connection at the rear. Tube included in the scope of delivery.	NZM3 PN3 N3	NZM3-XAD550 104556	Use only in combination with the auxiliary type (+)NZM3-XKR13. To be screwed onto the busbar by means of a claw-type of clamp.	1 unit
 <p>VT18806</p>	250	690	-	-	To cover the connection to the system at the top/bottom	NZM2 PN2 N2 NS2	NZM2-XKR4 281666	For device combination NZM2 use with the auxiliary type +NZM2-XKR40 or +NZM2-XKR4U	1 unit
 <p>VT18706</p>	550	690	-	-	To cover the connection to the system at the top	NZM3 PN3 N3	NZM3-XKR13 281668	For device combination NZM3 use with the auxiliary type NZM3-XKR130	1 unit

¹⁾ To be snapped onto the voltage-free busbar.

²⁾ Thanks to the combi-base it can be adjusted to a bar width of both 5 and 10 mm, cross-section of conductor 6 x 9 x 0.8.

xStart Busbar System, 3-pole ¹⁾									
Max. Rated Operating Current Ie (A)	Rated Operating Voltage Ue (V)	Wire Cross Section	Adapter Width (mm)	Adapter Length (mm)	Support Rails	Utilisation	Designation Article No.	Notes	Units per Package
xStart Busbar Adaptor									
25	690	AWG12	45	200	1	PKZM0+ Contactor DIL M 7 Contactor DIL M 9 Contactor DIL M 12 Contactor DIL M 15 MSC-D-0.25-M7... to MSC-D-16-M15...	BBA0-25 101451	Direct starter set PKZM0-XDM12	4 units
Also available as fully fitted and tested combination with MSC-D... -> HPL0211-2007/2008 Chapter 09									
25	690	AWG12	90	200	1	PKZM0+ 2x Contactor DIL M 7-01 2x Contactor DIL M 9-01 2x Contactor DIL M 12-01 MSC-R-0.25-M7... to MSC-R-12-M12...	BBA0R-25 101453	Reversing starter set PKZM0-XRM12	2 units
Also available as fully fitted and tested combination with MSC-R... -> HPL0211-2007/2008 Chapter 09									
32	690	AWG10	45	200	2	PKZM0+ Contactor DIL M 17 Contactor DIL M 25 Contactor DIL M 32 MSC-D-16-M17... to MSC-D-32-M32...	BBA0-32 101452	Electrical contact module PKZM0-XM32 DE	4 units
Also available as fully fitted and tested combination with MSC-D... -> HPL0211-2007/2008 Chapter 09									
32	690	AWG10	90	200	3	PKZM0+ 2x Contactor DIL M 17-01 2x Contactor DIL M 25-01 2x Contactor DIL M 32-01 MSC-R-16-M17... to MSC-R-32-M32...	BBA0R-32 101454	Electrical contact module PKZM0-XM32 DE Reverse wiring set DILM32-XRL	2 units
Also available as fully fitted and tested combination with MSC-R... -> HPL0211-2007/2008 Chapter 09									
63	690	AWG8	72	260	2	PKZ2+ Contactor DIL M 7 Contactor DIL M 9 Contactor DIL M 12 Contactor DIL M 17 Contactor DIL M 25 Contactor DIL M 32 Contactor DIL M 40	BBA2L-63 101480	Electrical connector for PKZ2 + DILM7...12: MVS-LB0-00M-G PKZ2+DILM17...32: MVS-LB0-0M-G	2 units
63	690	AWG8	72	200	1	PKZ2	BBA2-63 101458		4 units
63	690	AWG8	55	260	2	PKZM4+ Contactor DIL M 17 Contactor DIL M 25 Contactor DIL M 32 Contactor DIL M 40 Contactor DIL M 50 Contactor DIL M 60	BBA4L-63 101459	Electrical connector for PKZM4+DILM17...32: MVS-LB0-0M-G PKZM4+DILM40...65: PKZM4-XM65 DE	4 units
63	690	AWG8	55	200	1	PKZM4	BBA4-63 101457		4 units
Side Module									
-	-	-	9	200	-		BBA-XSM 101484	Can be placed on both sides of BBA, to increase the add-on width	10 units
¹⁾ Can be used with all busbars in a 60 mm system. Thanks to the combi-base it is suitable for both 5 mm and 10 mm thickness of the bar as well as for double-T-profile bars. To be snapped onto the voltage-free busbar.									

VT15906



VT14306



VT15706



VT14906



VT16406



VT16606



VT16906



xStart Busbar Adaptor, 3-pole ¹⁾

Max. Rated Operating Current Ie (A)	Rated Operating Voltage Ue (V)	Wire Cross Section	Adapter Width (mm)	Adapter Length (mm)	Support Rails	Utilisation	Designation Article No.	Notes	Units per Package
-------------------------------------	--------------------------------	--------------------	--------------------	---------------------	---------------	-------------	-------------------------	-------	-------------------

xStart Busbar Adaptor, for Spring-type Terminal

16	690	AWG14	45	200	2	PKZM0...C+ Contactor DIL M 7 Contactor DIL M 9 Contactor DIL M 12 Contactor DIL M 15	BBA0C-16 101455	For PKZM0C... with spring-type terminal technology	4 units
----	-----	-------	----	-----	---	--	---------------------------	--	---------

VT15506



VT14506



16	690	AWG14	90	200	3	PKZM0...C+ 2x Contactor DIL M 7-01 2x Contactor DIL M 9-01 2x Contactor DIL M 12-01	BBA0RC-16 101456	For PKZM0C... with spring-type terminal technology	2 units
----	-----	-------	----	-----	---	--	----------------------------	--	---------

xStart Busbar Adaptor, Universal Type

25	690	AWG12	45	200	2	Support rail adjustable on the 1.25 mm grid	BBA0-25/2TS 101481		4 units
----	-----	-------	----	-----	---	---	------------------------------	--	---------

VT15306



VT16106



–	–	–	45	200	2	Support rail adjustable on the 1.25 mm grid	BBA0/2TS-L 101482	Without electrical contacting, auxiliary to BBA... for the setup of reversing starters, for example	4 units
---	---	---	----	-----	---	---	-----------------------------	---	---------





VT16806







–	–	–	54	260	2	Support rail adjustable on the 1.25 mm grid	BBA4/2TS-L 101483	Without electrical contacting, auxiliary to BBA... for the setup of reversing starters, for example	4 units
---	---	---	----	-----	---	---	-----------------------------	---	---------

¹⁾ Can be used with all busbars in a 60 mm system. Thanks to the combi-base it is suitable for both 5 mm and 10 mm thickness of the bar as well as for double-T-profile bars. To be snapped onto the voltage-free busbar.

Slide Fuse Equipment, 3-pole

	Max. Rated Operating Current I _e (A)	Max. Fuse Link 500V (A)	Max. Fuse Link 690V (A)	Component Size	Utilisation	Designation Article No.	Notes	Units per Package
HRC-Fuse Switch Disconnecter								
	100	100	–	NH000	20 x 5/10 30 x 5/10	LTS-100/C00/3-R 284690	Width 63 mm. Connection at the bottom.	1 unit
	160	160	100	NH00	20 x 5/10 25 x 5/10 30 x 5/10 Double-T	GST00-160-40-60-AOU 224550	Connection at the top or bottom. No shock hazard protection.	1 unit
Ordering information on shock hazard protection see next page.								
	250	250	200	NH1	20 x 5/10 25 x 5/10 30 x 5/10 Double-T	GST1-AO 107250	Connection at the top. Including shock hazard protection at top and bottom.	1 unit
	250	250	200	NH1	20 x 5/10 25 x 5/10 30 x 5/10 Double-T	GST1-AU 107251	Connection at the bottom. Including shock hazard protection at top and bottom.	1 unit
	400	400	315	NH2	20 x 5/10 25 x 5/10 30 x 5/10 Double-T	GST2-AO 107252	Connection at the top. Including shock hazard protection at top and bottom.	1 unit
	400	400	315	NH2	20 x 5/10 25 x 5/10 30 x 5/10 Double-T	GST2-AU 107253	Connection at the bottom. Including shock hazard protection at top and bottom.	1 unit

Slide Fuse Equipment, 3-pole								
	Max. Rated Operating Current I _e (A)	Max. Fuse link 500V (A)	Max. Fuse link 690V (A)	Component Size	Utilisation	Designation Article No.	Notes	Units per Package
	HRC-Slide Fuse Equipment							
	630	630	500	NH3	20 x 5/10 25 x 5/10 30 x 5/10 Double-T	GST3-AO 107254	Connection at the top. Incl. shock hazard protection at top and bottom.	1 unit
	630	630	500	NH3	20 x 5/10 25 x 5/10 30 x 5/10 Double-T	GST3-AU 107255	Connection at the bottom. Incl. shock hazard protection at top and bottom.	1 unit
	Shock Hazard Protection Set GST00							
–	–	–	–	–	GST00...	BS-SET-GST00 107955	1 set includes shock hazard protection at the top and bottom.	1 unit
	Set of Prism Terminals							
	–	–	–	–	GST1...	PSK1 038734	One set includes 3 prism terminals	1 unit
	–	–	–	–	GST2...	PSK2 043480	One set includes 3 prism terminals	1 unit
	–	–	–	–	GST3...	PSK3 048226	One set includes 3 prism terminals	1 unit
	Set of Double-Prism Terminals							
	–	–	–	–	GST1...	PSK12 041107	One set includes 3 double-prism terminals	1 unit
	–	–	–	–	GST2...	PSK22 045853	One set includes 3 double-prism terminals	1 unit
	–	–	–	–	GST3...	PSK32 050599	One set includes 3 double-prism terminals	1 unit
	Clamp-Type of Terminal							
	–	–	–	–	GST1...	SK1-GS 107960		3 units
	–	–	–	–	GST2...	SK2-GS 107961		3 units
	–	–	–	–	GST3...	SK3-GS 107962		3 units

Slide Fuse Equipment, 3-pole

Max. Rated Operating Current I _e (A)	Rated Voltage U _e (V AC)	Component Size	Width	Utilisation	Designation Article No.	Notes	Units per Package
---	-------------------------------------	----------------	-------	-------------	-------------------------	-------	-------------------

D-Type Slide Fuse Equipment

25	500	E27, D II	45	12 x 5/10 20 x 5/10 25 x 5/10 30 x 5/10 Double-T	DII-SO/25/3-R 107965	Incl. cover for shock hazard protection, with front and bottom plate and labelling plate. Supplied empty, without screw caps.	1 unit
----	-----	-----------	----	--	--------------------------------	---	--------

SG12506



63	380 400	E18, D 02	27	12 x 5/10 20 x 5/10 25 x 5/10 30 x 5/10 Double-T	D02-SO/63/3-R 107964	Incl. cover for shock hazard protection, with front and bottom plate and labelling plate. Supplied empty, without screw caps.	1 unit
----	------------	-----------	----	--	--------------------------------	---	--------

SG12406



63	660 690	E33, D III	54	12 x 5/10 20 x 5/10 25 x 5/10 30 x 5/10 Double-T	DIII-SO/63/3-R 107966	Incl. cover for shock hazard protection, with front and bottom plate and labelling plate. Supplied empty, without screw caps.	1 unit
----	------------	------------	----	--	---------------------------------	---	--------

SG12606



Side Cover

–	–	–	–	D...	SBS-RS60 060541	Suitable for D...-SO/.../3-R	10 units
---	---	---	---	------	---------------------------	------------------------------	----------

D02 Switch Disconnecter

63	400	E18, D 02	36	20 x 5/10 30 x 5/10 Double-T	D02-S/63/3-RS 284649	Supplied empty, without screw caps.	10 units
----	-----	-----------	----	------------------------------------	--------------------------------	-------------------------------------	----------

SG18705



Max. Rated Operating Current I _e (A)	Dimensions (Number of layers x width x thickness of layers) (mm)	Cross Section (mm ²)	Designation Article No.	Notes	Units per Package
Multi-layer Copper Band, insulated					
<ul style="list-style-type: none"> • E-Cu conductor, tin-plated • Rated voltage 690 V AC • UL-listed for max. 600 V AC • Breakdown voltage 20 kV/mm • Insulating material heat resistant up to +105° Celsius • Self-extinguishing according to UL94VO • 2000 mm long 					
100	3 x 9 x 0.8	21.6	CU-BAND3X9X0,8-BK 081167	black	20 units
	3 x 9 x 0.8	21.6	CU-BAND3X9X0,8-BU 080960	blue	20 units
	3 x 9 x 0.8	21.6	CU-BAND3X9X0,8-GNYE 081006	green/yellow	20 units
160	6 x 9 x 0.8	43.2	CU-BAND6X9X0,8-BK 081414	black	10 units
	6 x 9 x 0.8	43.2	CU-BAND6X9X0,8-BU 081344	blue	10 units
	6 x 9 x 0.8	43.2	CU-BAND6X9X0,8-GNYE 081367	green/yellow	10 units
200	9 x 9 x 0.8	64.8	CU-BAND9X9X0,8-BK 081515	black	10 units
	9 x 9 x 0.8	64.8	CU-BAND9X9X0,8-BU 081436	blue	10 units
	9 x 9 x 0.8	64.8	CU-BAND9X9X0,8-GNYE 081485	green/yellow	10 units
250	6 x 16 x 0.8	74.4	CU-BAND6X16X0,8-BK 081310	black	10 units
	6 x 16 x 0.8	74.4	CU-BAND6X16X0,8-BU 081222	blue	10 units
	6 x 16 x 0.8	74.4	CU-BAND6X16X0,8-GNYE 081275	green/yellow	10 units
400	10 x 16 x 0.8	124	CU-BAND10X16X0,8-BK 080739	black	5 units
	10 x 16 x 0.8	124	CU-BAND10X16X0,8-BU 079736	blue	5 units
	10 x 16 x 0.8	124	CU-BAND10X16X0,8-GNYE 080698	green/yellow	5 units
630	11 x 21 x 1	231	CU-BAND11X21X1-BK 080923	black	5 units
	11 x 21 x 1	231	CU-BAND11X21X1-BU 080769	blue	5 units
	11 x 21 x 1	231	CU-BAND11X21X1-GNYE 080836	green/yellow	5 units

VT14106

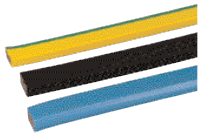

SASY 60i Busbar System

Table of Contents SASY 60i Busbar System

Busbar supports	Page 26
HRC-Fuse Switch Disconnectors	Page 28
D-Type Fuse Equipment	Page 29
Busbar-Slide Switch Disconnecter with Fuses	Page 29
60 mm System	Page 30
Dimensions	Page 35
UL/CSA approvals list	Page 45
Copper weight, extra charges	Page 46

SASY 60i Busbar System

Technical Data on Busbar Supports

			BBS-3/FL(-NA)	BBS-3/PR
General Information				
Standards and regulations			type-tested according to VDE 0660 Part 500IEC/EN 60439-1	
Fitting position			vertical position of bar width, any	
Tightening torque of cover	Md	Nm	4	4
Material				
Material			Thermoplast	Thermoplast
Halogens			halogen-free	halogen-free
Flammability			self-extinguishing according to UL 94-VO	
Colour			RAL 7035	RAL 7035
Creepage resistance			CTI 200	CTI 200
Continuous operation temperature			°C	120°C
Current Paths				
Rated insulation voltage	Ui	V	3000	3000
Rated operating voltage	Ue	V	690	690
Rated frequency	f	Hz	50/60	50/60
Centre line distance of busbars		mm	60	60
Rated constant current ¹⁾				
with busbar 12 x 5 mm	Iu	A	218	-
with busbar 15 x 5 mm	Iu	A	273	-
with busbar 20 x 5 mm	Iu	A	349	-
with busbar 25 x 5 mm	Iu	A	436	-
with busbar 30 x 5 mm	Iu	A	491	-
with busbar 12 x 10 mm	Iu	A	392	-
with busbar 20 x 10 mm	Iu	A	567	-
with busbar 30 x 10 mm	Iu	A	687	-
with 500 mm ²	Iu	A	-	1003
with 720 mm ²	Iu	A	-	1281
Ambient temperature			°C	35
Temperature of busbar			°C	70
Rated peak withstand current ²⁾				
with busbar 12 x 5 mm	Ipk	kA	50	-
with busbar 15 x 5 mm	Ipk	kA	50	-
with busbar 20 x 5 mm	Ipk	kA	50	-
with busbar 25 x 5 mm	Ipk	kA	50	-
with busbar 30 x 5 mm	Ipk	kA	64	-
with busbar 12 x 10 mm	Ipk	kA	56	-
with busbar 20 x 10 mm	Ipk	kA	56	-
with busbar 30 x 10 mm	Ipk	kA	73	-
with 500 mm ²	Ipk	kA	-	72
with 720 mm ²	Ipk	kA	-	87
Short-circuit time	t	ms	20	20
Support centre line distance		mm	250	500

¹⁾ In case of temperature variances, DIN 43671 requires a kA orrection factor to be taken into account.

²⁾ For other support centre line distances, please refer to the short-circuit strength diagrams.

Short-circuit strength diagrams according to IEC/EN 60439-1 for 60 mm SASY 60i Busbar Systems

BBS-3/FL

107066

• Values measured during type-testing

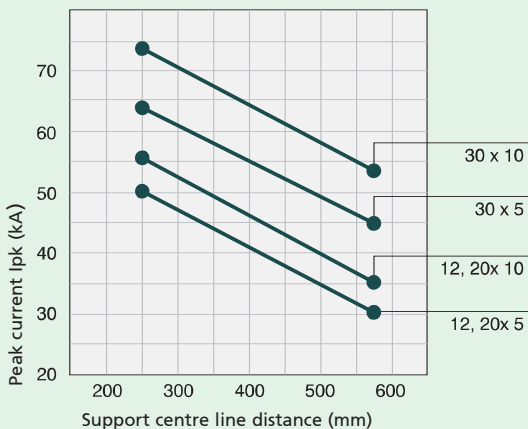

BBS-3/PR

107162

• Values measured during type-testing

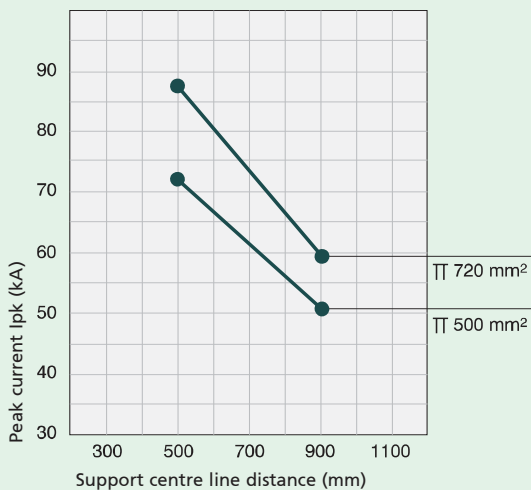

SASY 60i Busbar System

Short-circuit strength diagrams according to UL 845 for 60 mm SASY 60i Busbar Systems

BBS-3/FL-NA

107067

• Values measured during type-testing

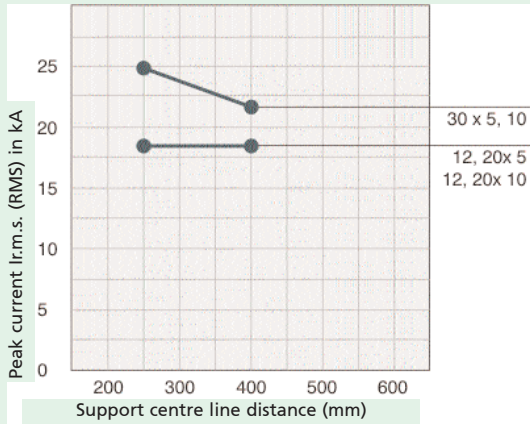

BBS-3/PR

107162

• Values measured during type-testing

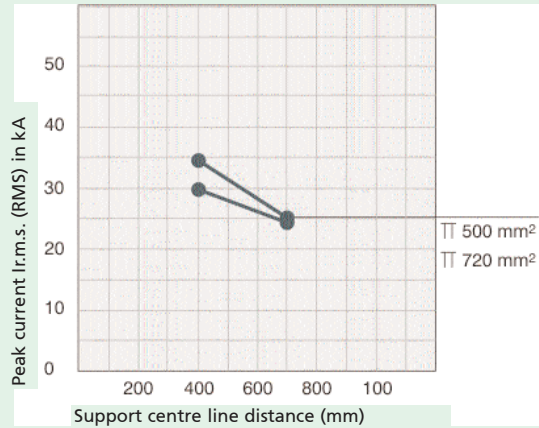

Current load TT 500 mm²

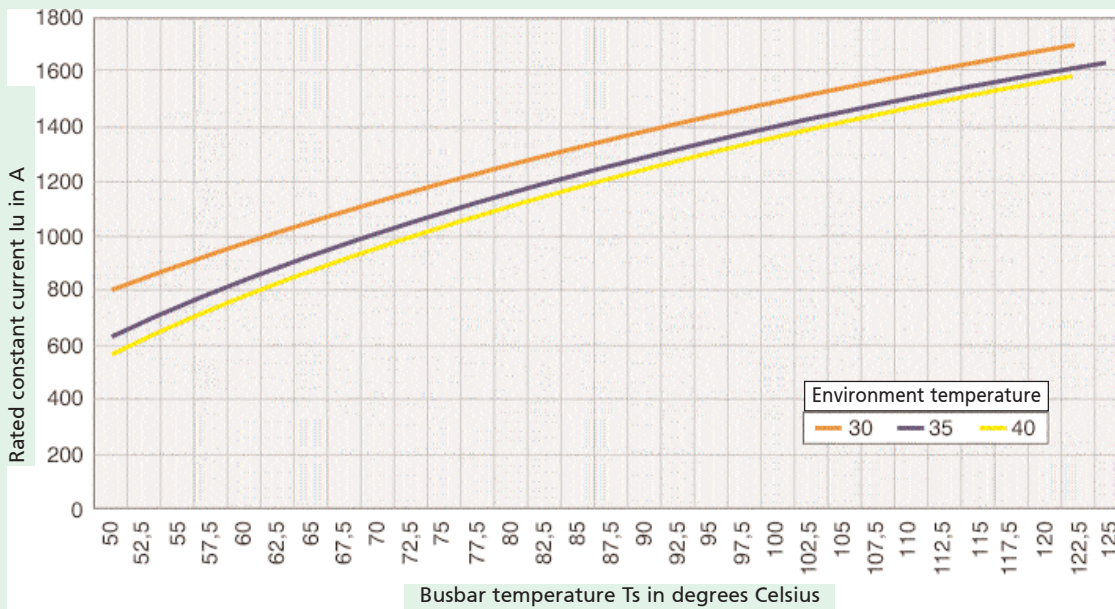

Current load TT 720 mm²

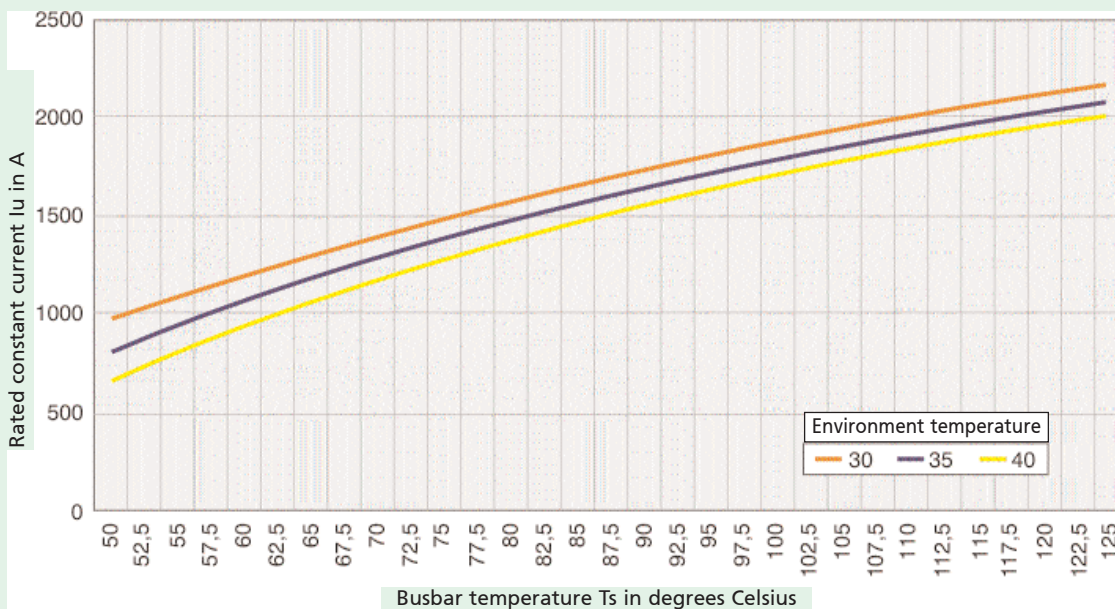

SASY 60i Busbar System

Technical Data on HRC-Fuse Switch Disconnectors

		LTS-100/C00/3-R	GST..00-160	GST..1	GST..2	GST..3
General information						
Climatic resistance		Moist heat, constant according to IEC 60068-2-78 Moist heat, cyclical according to IEC 60068-2-30				
Ambient temperature	°C	-25 to +55				
Mounting height	m	max. 2000				
Fitting position		vertical, horizontal				
Overvoltage category/Degree of pollution		III/3				
Direction of power infeed		any				
<i>HRC-Fuse switch disconnecter</i>						
Standards and regulations		IEC/EN 60947-3				
Shock hazard protection at the front						
Operating status / Front cover open		IP20 / IP10				
Weight	kg	0.57	0.93	4.4	5.3	6.6
Current paths						
<i>HRC-Fuse switch disconnecter</i>						
Rated operating voltage	Ue	V AC	500	500 / 690	500 / 690	500 / 690
Rated operating voltage	Ue	V DC	220	220 / 440	220 / 440	220 / 440
Rated operating current	Ie	A	100	160 / 100	250 / 200	400 / 315
Rated frequency		Hz	40 - 60	40 - 60	40 - 60	40 - 60
Conditional rated short-circuit current AC		kAr.m.s.	50	50	50	50
Conditional rated short-circuit current DC		kAr.m.s.	25	25	25	25
Utilisation category AC-22B						
Rated making capacity		A	300	480 / 300	750 / 600	1200 / 945
Rated breaking capacity		A	300	480 / 300	750 / 600	1200 / 945
Utilisation category DC-21B						
Rated making capacity		A	400	150	300	475
Rated breaking capacity		A	400	150	300	475
Service life - electrical			300	300	200	200
Service life - mechanical			1700	1700	1400	800
Power loss with IthAC, without NH-SE		W	11.5	6.9 / 2.7	12.9 / 8.3	27 / 16.7
Power loss with IthDC, without NH-SE		W	7.7	4.6 / 1.8	8.6 / 5.5	18 / 11.2
Rated insulation voltage	Ui	V AC	500	750	750	750
Max. Fuse link						
Size of component			NH000	NH00	NH1	NH2
Max. rated current gl/gG		A	100	160	250	400
Max. power loss permissible of NH-SE	Pv	W	7.5	12	23	34
Cross sections of connections						
Flat connection (F)				F ¹⁾	F ¹⁾	F ¹⁾
Bolt diameter				M10	M10	M10
Cable lug		mm ²		1 x 25-150	1 x 25-240	1 x 25-300
Flat busbar		mm		30 x 10	30 x 10	30 x 10
Tightening torque		Nm		30 - 35	30 - 35	30 - 35
Clamp-type terminal (S) / Pillar terminal (K)			K ¹⁾	K ¹⁾	S	S
Multi-wire Cu		mm ²	1.5 - 50	1,5 - 70	25 - 150	25 - 240
Cu-Band		No. of layers x width x thickness	6 x 9 x 0.8	6 x 9 x 0.8	6 x 16 x 0.8	10 x 16 x 0.8
Tightening torque		Nm	2.6	2.6	9.5	23
Prism terminal						
Multi-wire Al/Cu		mm ²		70 - 150	120 - 240	120 - 300
Tightening torque		Nm		4.5	11	11
Double-prism terminal						
Multi-wire Al/Cu		mm ²		2x70-95	2x120-150	2x120-240
Tightening torque		Nm		4.5	11	11

¹⁾ Standard-connection in the delivery condition

SASY 60i Busbar System

Technical Data on D-Type Fuse Equipment

Slide-Type Base Parts for Fuse Equipment	D02-SO/63/3-R	DII-SO/25/3-R	DIII-SO/63/3-R
--	---------------	---------------	----------------

General information

Standards and regulations	VDE 0636 VDE 0636 for base parts of fuses Cover caps according to VDE 0636 Adapter ring system, DIN 49326, DIN 49327, DIN 49524		
Climatic resistance	Moist heat, constant, according to IEC 60068-2-78 Moist heat, cyclical, according to IEC 60068-2-30		
Ambient temperature	°C	-5/+25; +40 (top limit, if annual and 24-hours average $\leq 35^{\circ}\text{C}$)	
Fitting position	any	any	any

Current paths

Rated operating voltage	U _e	V AC	400	500	690
Rated constant current	I _u	A	63	25	63
Current heat loss per current path with constant current I _u incl. fuse link		W	5.5	3.9	7.5

Cross-section of connections

single-wired	mm ²	2.5 - 16	1.5 - 6	2.5 - 16
multi-wired	mm ²	2.5 - 16	1.5 - 6	2.5 - 16
fine-wired with wire end ferrule	mm ²	2.5 - 16	1.5 - 6	2.5 - 16

Technical Data on Busbar-Slide Switch Disconnecter with Fuses D02-S/63/3-RS

- Design according to IEC/EN 60947-3
- For 60mm busbar systems of a thickness of 5 or 10mm
- Bar grid for busbars 20 and 30 mm wide
- Supplied empty, without screw caps
- Current coding through ring adapter insert
- Suitable for fuses
 - D01: 2, 4, 6, 10, 16 A in combination with cartridge ring adapter inserts Z-D02-D01/PE-.. and retaining spring Z-D02/SIKA-HF
 - D02: 20, 25, 35, 50, 63 A
- Can be sealed with lead

Connection diagram

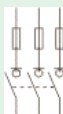

Technical Data

Electrical

Number of poles	3P
Rated operating voltage U _e	AC 400 V / 40-60 Hz
Rated operating current I _e	63 A
Conv. thermal current with fuse links I _{th}	63 A
Rated type of operation	Continuous operation
Conditional rated short-circuit current	50 kA _{r.m.s.}
Utilisation category	AC 23 B
Overvoltage category	III
Rated peak withstand voltage U _{imp}	8 kV
Current heat loss per current path	0.5 W with I _e
Power loss per current path with fuse link	7.5 W with I _e
Max. permissible power loss of fuse links	5.5 W

Mechanical

Size of device base	212 mm
Fitting width	36 mm
Weight	260 g
Mounting	onto busbars with 60 mm spacing
Degree of protection while operating	IP30
Terminals	Lift terminals
Cross-section of termination	1.5-25 mm ² Cu
Tightening torque of terminal screws	max. 2.6 Nm
Electrical thread type	E18
Temperature range	-25 to +55°C
Degree of pollution	3

SASY 60i Busbar System

Technical Data on the 60 mm System

Conductor connections

The ratios between conductor cross-sections in mm² and AWG/MCM-sizes are listed below:

1.5 mm ²	16 AWG
2.5 mm ²	14 AWG
4 mm ²	12 AWG
6 mm ²	10 AWG
10 mm ²	8 AWG
16 mm ²	6 AWG
25 mm ²	4 AWG
35 mm ²	2 AWG
50 mm ²	0 AWG
70 mm ²	2/0 AWG
95 mm ²	3/0 AWG
120 mm ²	250 MCM
150 mm ²	300 MCM
185 mm ²	350 MCM
240 mm ²	500 MCM
300 mm ²	600 MCM

Busbar supports

60 mm system according to IEC

1-pole for busbars 12x5 – 30x10, double-T-bars

2-pole for busbars 12x5 – 30x10

3-pole for busbars 12x5 – 30x10 and 12/20/ 30 x 5/10

3-pole for double-T-bars

Tighten screws for fixing the cover and bottom of the support at a torque of 4 Nm min.

60 mm system according to UL

3-pole for busbars 12/20/ 30 x 5/10

3-pole for double-T-bars

Tighten screws for fixing the cover and bottom of the support at a torque of 4 Nm min.

Silicon-free, chlorine-free

Temperature resistant up to 120°C

Self-extinguishing according to UL 94

Creepage resistance CTI 200

Busbars according to DIN EN 13601

Tin-plated Cu-bars significantly reduce the work necessary for preparing the contact points.

Cu-busbars are effectively protected against aggressive environments.

Dimension	Cross-section
Double-T	500 mm ²
Double-T	720 mm ²

Permissible tolerances:

Radius R 0.3 ... 0.7

Width: + 0.1 / – 0.5

Thickness: + 0.1 / – 0.1

Center line distance:

± 0.5 mm (60 mm system)

Variance on the contacting level: 0.4 mm

SASY 60i Busbar System

Technical Data on the 60 mm System

Busbars according to DIN EN 13601

The UL 508A standard limits the permissible current density for busbars to a value of 1000 A / inch² (1.55 A /mm²).

The higher current carrying capacities to DIN 43671 were obtained under operating conditions.

The busbar temperature is normally positively influenced by mounting components on the busbar and by air circulation within the installation.

Depending on the respective ambient temperature, you can calculate the correction factor k₂ according to DIN 43 671 for flat busbars. If ambient conditions change, a correction factor needs to be taken into account.

On the other hand, increased loads may occur if the components feature a correspondingly high temperature resistance.

A 30 x 10 tin-plated busbar can under normal conditions be loaded with 630 A. With a load of 800A, for instance, a k₂ correction factor of 1.3 is necessary. It follows from the diagram that with this factor and 35° C air temperature, the busbar heats up to approx. 85°C.

Base plate

Silicon-free, chlorine-free

Temperature resistant up to 110°C

Self-extinguishing according to UL 94

Busbar covers

for busbars of 12 x 5, 12-30 x 5, 12-30 x 10

Double-T-Profiles

Silicon-free, chlorine-free

Temperature resistant up to 110°C

Self-extinguishing according to UL 94

Modular system cover

to be attached to 60 mm systems, 3-pole

to busbars of 12/20/30 x 5/10, 25 x 5,

to double-T-profiles

Cover profile	front
Cover profile	top/bottom
Cover profile	support

Silicon-free, chlorine-free

Temperature resistant up to 120°C

Self-extinguishing according to UL 94

SASY 60i Busbar System

Technical Data on the 60 mm System

Universal conductor terminal

Used for connecting conductors featuring cross-sections of 1.5–120 mm² on busbars 5 or 10 mm thick.

Integrated retaining springs, an open terminal space and terminal screws impossible to get lost make the installation job easy.

Suitable conductors ¹⁾	Current carrying capacity of contact point*	Tightening torque Nm	Terminal space WxH mm	Busbars WxH mm	Type
1.5–16 mm ² Cu, ○, ⊙, ⊗**, ≡ 8 x 6 x 0.5	180 A	4	7.5 x 7.5	... x 5 ... x 10	AKU16/5 AKU16/10
4–35 mm ² Cu, ○, ⊙, ⊗**, ≡ 3/ 6 x 9 x 0.8	270 A	6	10.5 x 11	... x 5 ... x 10	AKU35/5 AKU35/10
16–70 mm ² Cu, ⊙, ⊗**, 2 x ≡ 3 / 6 x 9 x 0.8, 6 x 13 x 0.5	400 A	10	14 x 14	... x 5 ... x 10, TT	AKU70/5 AKU70/10
16–120 mm ² Cu, ⊙, ⊗**, ≡ 4 / 6/ 10 x 16 x 0.8	440 A	15	17 x 15	... x 5 ... x 10, TT	AKU120/5 AKU120/10

* The current carrying capacities specified reflect the thermal capacities of the contact points under favourable conditions (with a maximum of conductors that can be connected). They do not, however, invalidate the validity of conductor cross-sections and of current carrying capacities required by any national and international regulations.

** A reduction of the maximum conductor cross-sections might be necessary.

Brace terminals

For connecting round conductors of 95–300 mm² and multi-layer copper bars.

The gripper-type of termination technology allows to embrace both sides of the busbar and to connect the conductor without drilling.

Suitable conductors ¹⁾	Contact carrying capacity of contact point *	Tightening torque Nm	Terminal space WxH mm	Busbars WxH mm	Type
95–185 mm ² Cu, Al*** ⊙, ⊙, ⊗	500 A	30	–	20x5 - 30x10 TT	AKS185
150–300 mm ² Cu, Al*** ⊙, ⊙, ⊗	600 A	30	–	20x5 - 30x10 TT	AKS300
≡ 3 x 20 x 1 to 10 x 32 x 1	800 A	30	32 X 25	20x5 - 30x10 TT	AKS-CU-BAND

*** Connections to aluminium conductors are not maintenance-free

- ¹⁾ ○ Round conductor, single-wired
 ⊙ Round conductor, fine-wired with expertly pressed wire end ferrule
 ⊗ Round conductor, multi-wired
 ⊙ Sector conductor, single-wired
 ⊗ Sector conductor, multi-wired
 ≡ Cu-Band
 ■ Cu-Bar

SASY 60i Busbar System

Technical Data on the 60 mm System

Connecting terminal plates

Incl. cover cap

50, 120 mm²

3-pole, 690 V~

Centre line distance of bars 60 mm

Busbars ... x 5 – 10,

Double-T-profiles

Terminal plates:

Silicon-free, chlorine-free

Temperature resistant up to 120°C

Self-extinguishing according to UL 94









Creepage resistance CTI 200

Cover cap:

Silicon-free, chlorine-free

Temperature resistant up to 120°C

Self-extinguishing according to UL 94

Suitable conductors ¹⁾	Current carrying capacity of contact point *	Tightening torque Nm	Terminal space WxH mm	Busbars WxH mm	Type
6–50 (70) mm ² Cu,   **,   6 x 9x 0.8	300 A	8 - 10	10 x 15	... x 5 – 10 TT	BBA-TP3/50
35–120 mm ² Cu,   **,   6 / 10 x 16 x 0.8	440 A	12 - 15	15 x 15	... x 5 – 10 TT	BBA-TP3/120

Connecting set, 3-pole

Incl. cover cap





300 mm², 10 x 32 x 1

1-pole, 690 V~

Centre line distance of bars 60 mm







Busbars 20x5 - 30x10

Double-T-profiles

Suitable conductors	Current carrying capacity of contact point *	Tightening torque Nm	Terminal space WxH mm	Busbars WxH mm	Type
120–300 mm ² Cu, Al***,   	560 A	30		20x5 - 30x10 TT	BBA-TP3/300
 3 x 20 x 1 to 10 x 32 x 1	800 A	30	32 x 25	20x5 - 30x10 TT	BBA-TP3/CUBAND

** It might be necessary to reduce the maximum conductor cross sections.

*** Connections to aluminium conductors are not maintenance-free.

- ¹⁾  Round conductors, single-wired
 Round conductors, fine-wired with expertly pressed wire end ferrules
 Round conductors, multi-wired
 Sector conductors, single-wired
 Sector conductors, multi-wired
 Cu-Band
 Cu-Bar

SASY 60i Busbar System

Technical Data on the 60 mm System

Busbar connecting terminal

For lengthwise connection of identically shaped busbars without drilling

Current carrying capacity of contact point	Overall length mm	Permissible mis-alignment of bars	Tightening torque Nm	Spacing between systems in mm	Type
630 A	150	1 mm	12	100 - 110	BBT-CU12-20X5/10-150
630 A	95	5 mm	20	50 - 60	BBT-CU20-30X5/10-95
630 A	150	5 mm	30	100 - 110	BBT-CU20-30X5/10-150
1600 A	50	2 mm	20	9 - 20	BBT-CU-BAR500/720-50
1600 A	150	5 mm	20	100 - 110	BBT-CU-BAR500/720-150

Profile terminals for double-T-bars

Current carrying capacity of contact point	Profile	Terminal space W x H (without spacers)	Tightening torque Nm	Type
1600 A	TT	41 x 20 – 42	40	AKP800
1600 A	TT	51 x 20 – 42	40	AKP1000

Use spacers provided when two multi-layer CU-BAND types of copper busbars are connected in parallel.

xStart busbar adaptor

3-pole, 690 V~

Can be used on all busbars in a 60 mm system.

Thanks to the combi-base it is suitable for a thickness of both 5 and 10 mm.

DIN EN 60715 support rail, plastic, can be adjusted on a 1.25-mm grid.

Copper conductors are ultrasound welded.

Base body:

Silicon-free, chlorine-free

Temperature resistant up to 120°C

Self-extinguishing according to UL 94

Creepage resistance CTI 200

Support rails:

Silicon-free, chlorine-free

Temperature resistant up to 100°C

PVC conductor insulation:

Temperature resistant up to 105°C

Busbar adaptor NZM

Parameter	NZM1-XAD160	NZM2-XAD250	NZM3-XAD550
Design	3-pole, 690 V~	3-pole, 690 V~	3-pole, 690 V~
Bar system	60 mm	60 mm	60 mm
Bar contacting	combi-base	claw-type terminal	claw-type terminal
Tightening torque at bar	-	8	12
Tightening torque of tube connection	-	8	40
Connection of the switchgear	top	top or bottom	top

NZM1-XAD160

Base body:

Thermoplast

Temperature resistant up to 120°C

Self-extinguishing according to UL 94

Creepage resistance CTI 200

Halogen-free

Conductor insulation:

PVC,

Temperature resistant up to 105 °C

NZM2-XAD250

Base body:

Thermoplast

Temperature resistant up to 120°C,

Self-extinguishing according to UL 94,

Creepage resistance CTI 200,

Halogen-free

NZM3-XAD550

Base body:

Thermoplast

Temperature resistant up to 120°C,

Self-extinguishing according to UL 94,

Creepage resistance CTI 200,

Halogen-free

SASY 60i Busbar System

Dimensions

BBS-3/FL

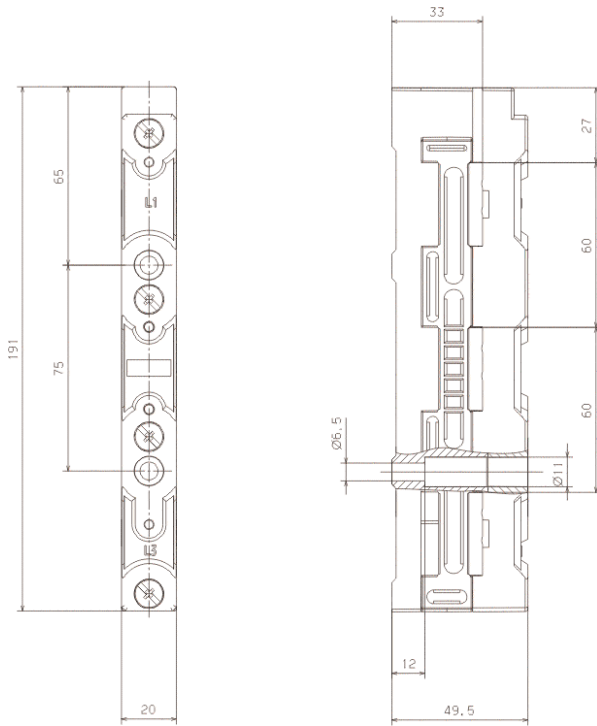

BBS-3/FL-NA

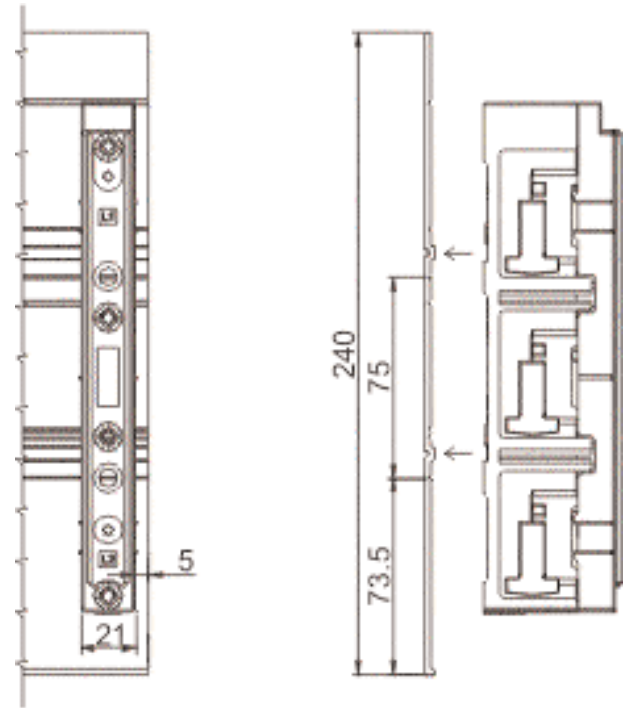

ES-BBS-3/FL

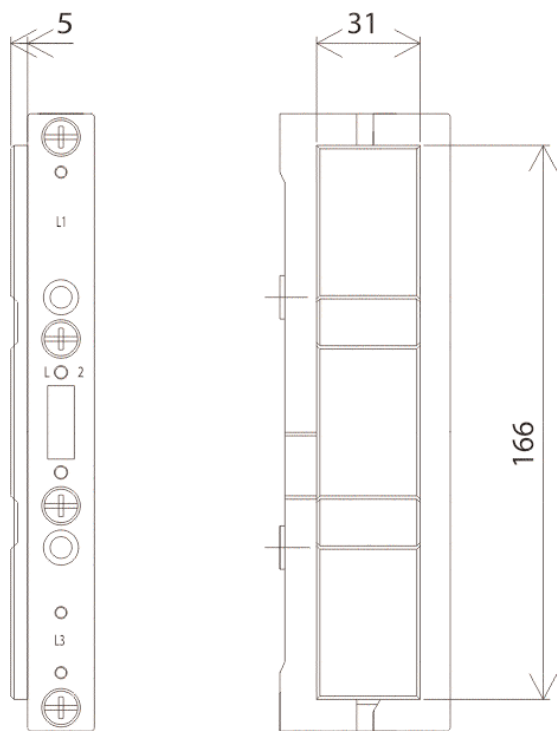

BBS-2/FL

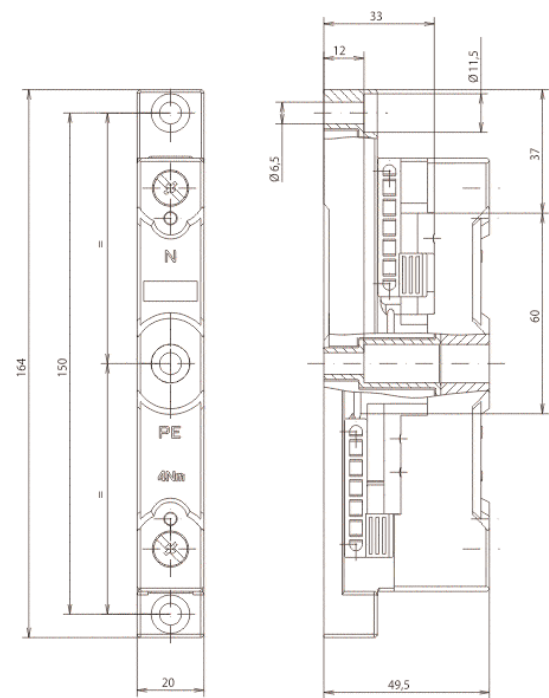

SASY 60i Busbar System

Dimensions

BBS-1/FL

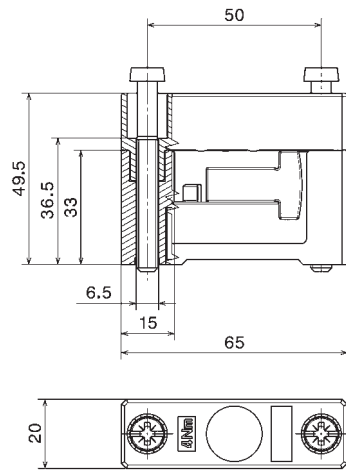

BBS-3/PR

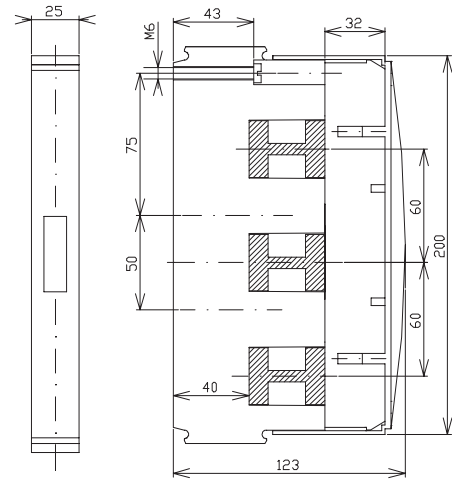

BBS-1/PR

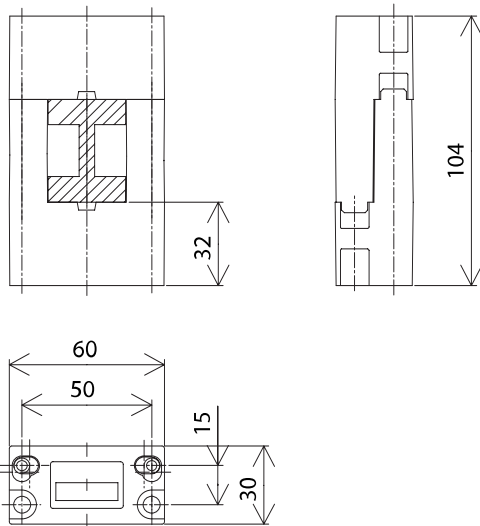

ES-BBS-3/PR

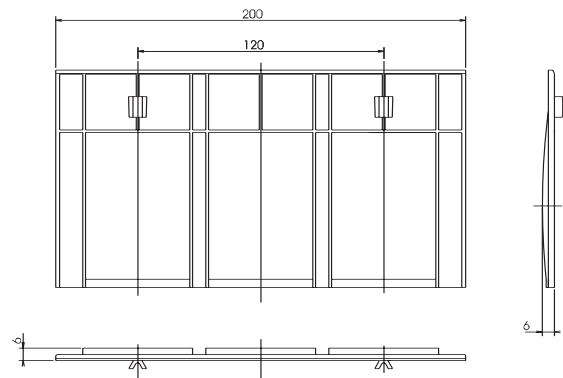

BBC-BT-NA

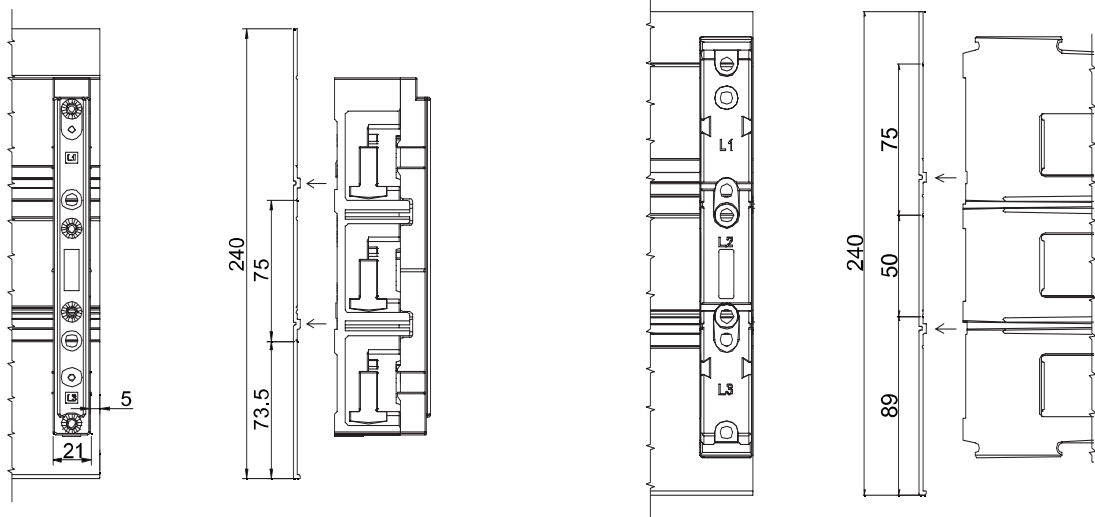

SASY 60i Busbar System

Dimensions

CU-BAR-500/T

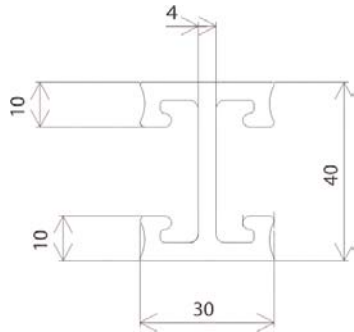

CU-BAR-720/T

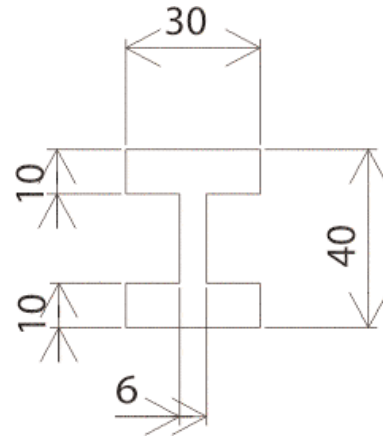

BBC-CU-BAR/PR

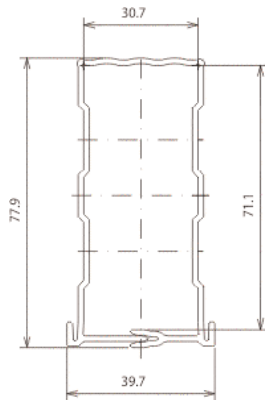

BBC-RCOV1

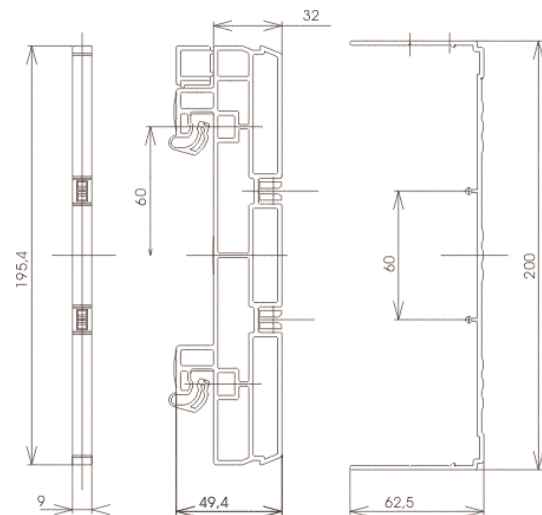

BBC-CS2-F + BBC-CS2-T/B + BBC-MCS2

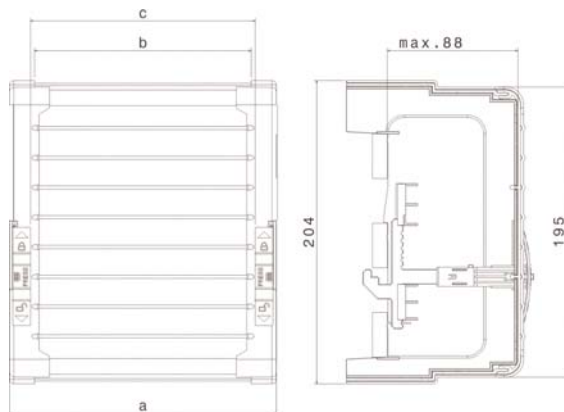

BBC-CS48/PR

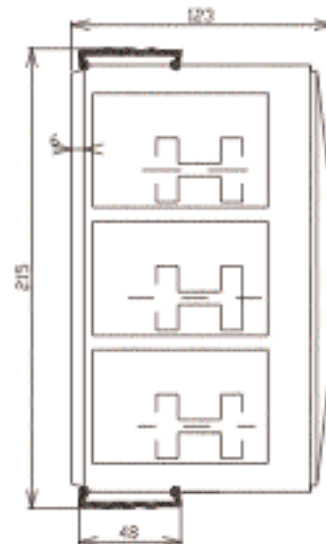

SASY 60i Busbar System

Dimensions

BBC-CS76/PR

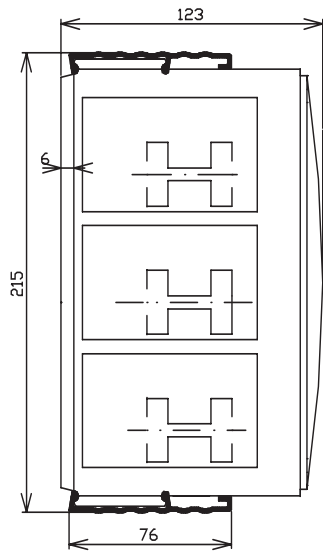

BBA-TP3/50

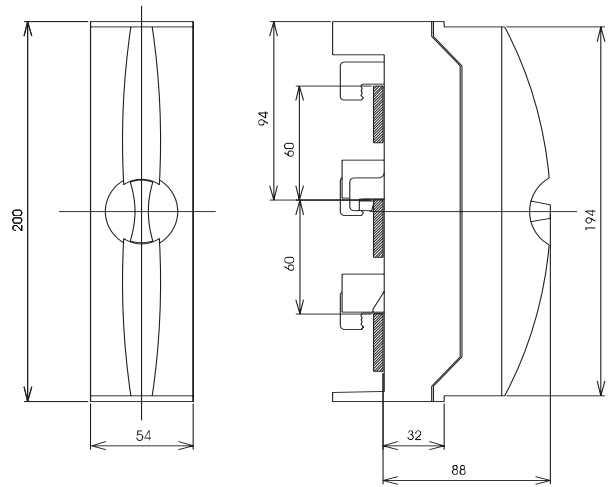

BBA-TP3/120

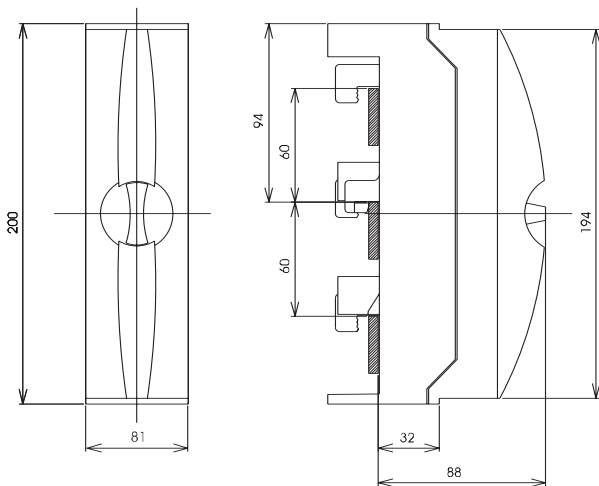

BBA-TP3/300

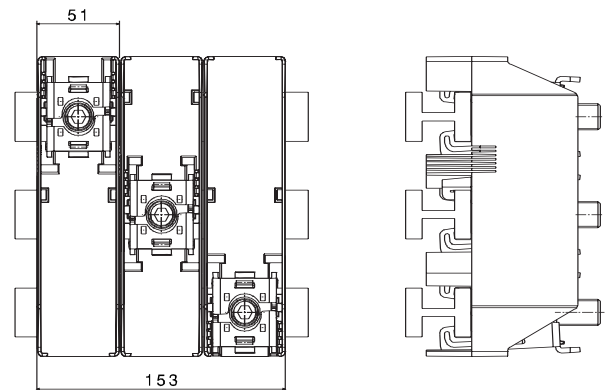

BBA-TP3/CU-Band

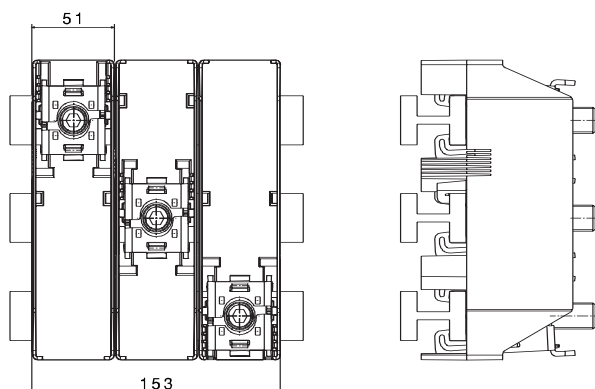

AKS185

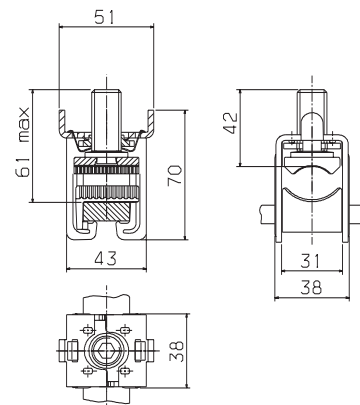

SASY 60i Busbar System

Dimensions

AKS300

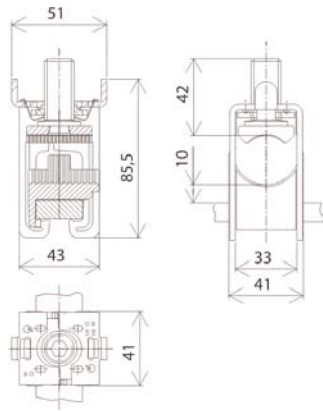

AKS-CU-BAND

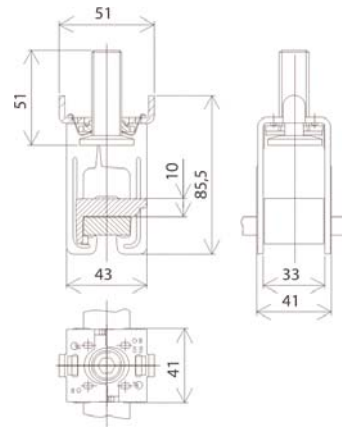

AKP1000

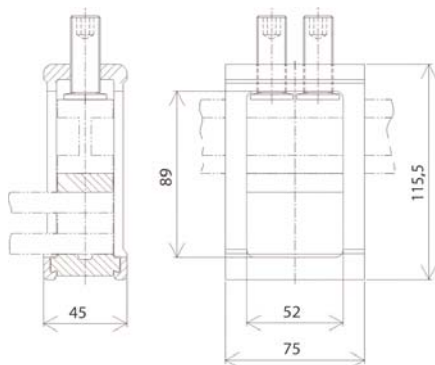

AKU 16/5

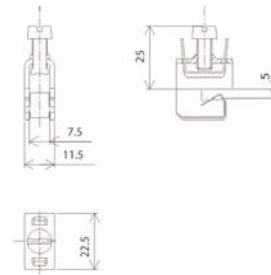

AKU 35/5

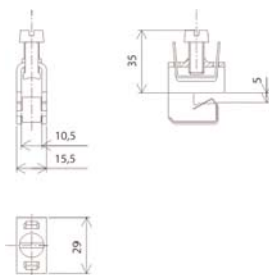

AKU 70/5

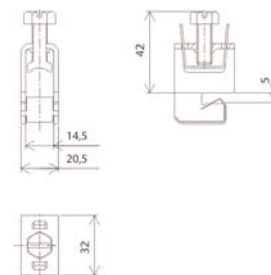

SASY 60i Busbar System

Dimensions

AKU 120/5

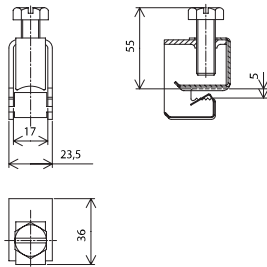

AKU 16/10

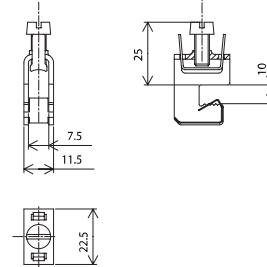

AKU 35/10

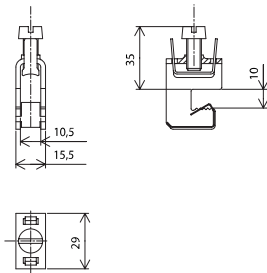

AKU 70/10

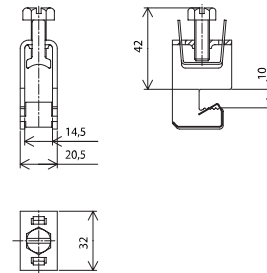

AKU 120/10

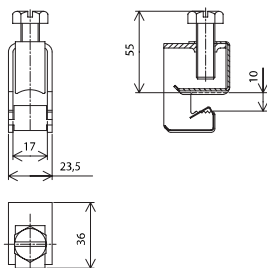

BBT-CU20-30X5/10-95

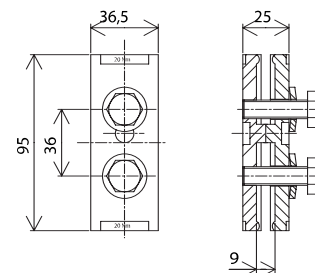

SASY 60i Busbar System

Dimensions

BBT-CU20-30X5/10-150

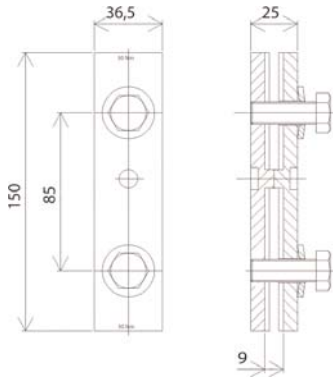

BBT-CU-BAR500/720-50

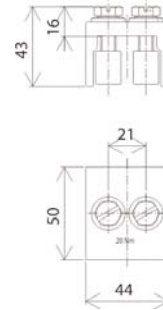

BBT-CU-BAR500/720-150

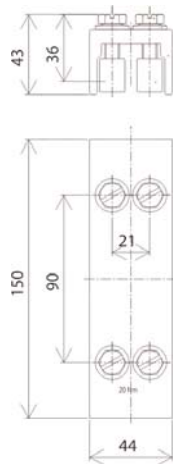

BBT-CU12-20x5/10-150

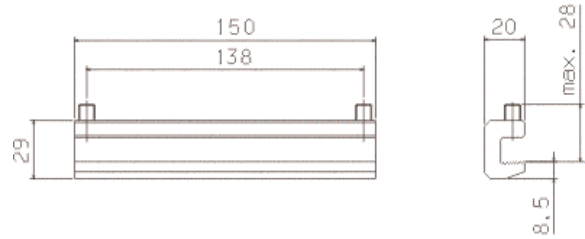

SASY 60i Busbar System

Dimensions

NZM1-XAD160

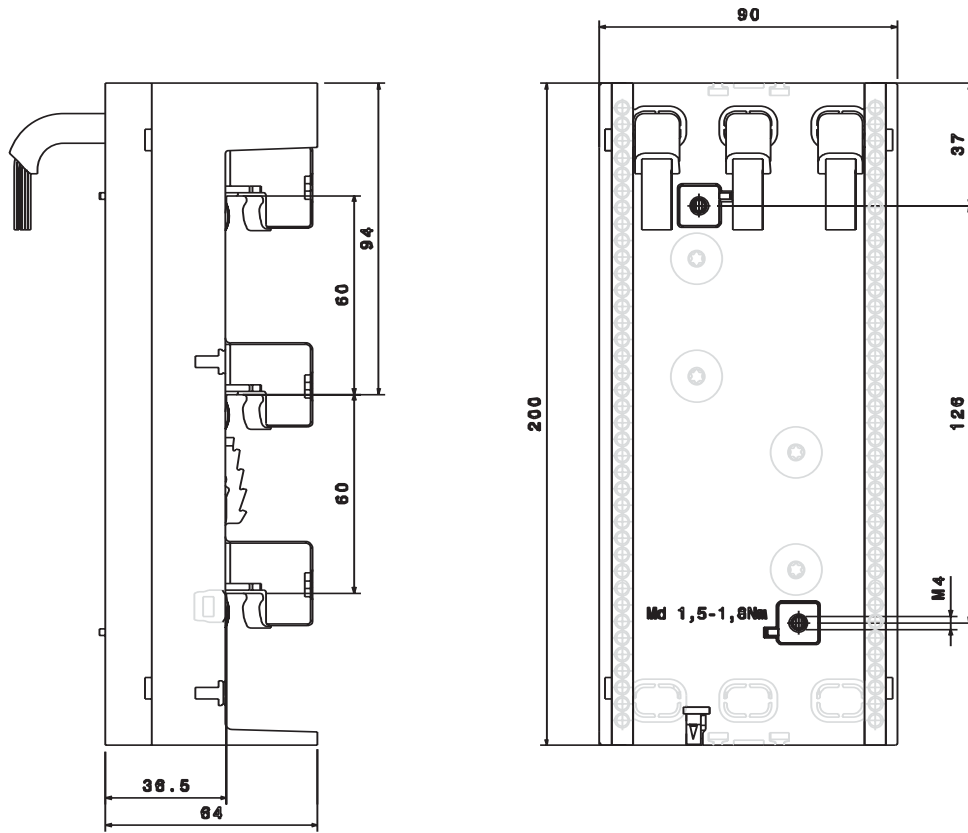

NZM2-XAD250

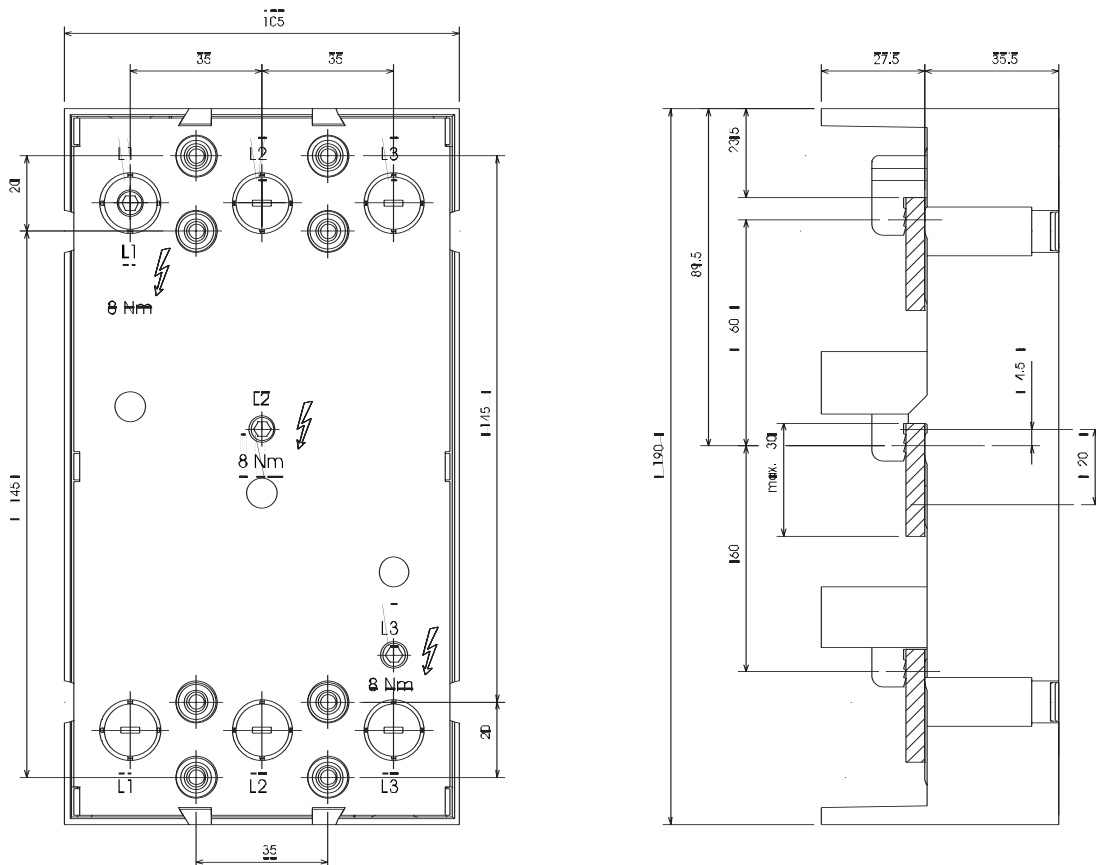

SASY 60i Busbar System

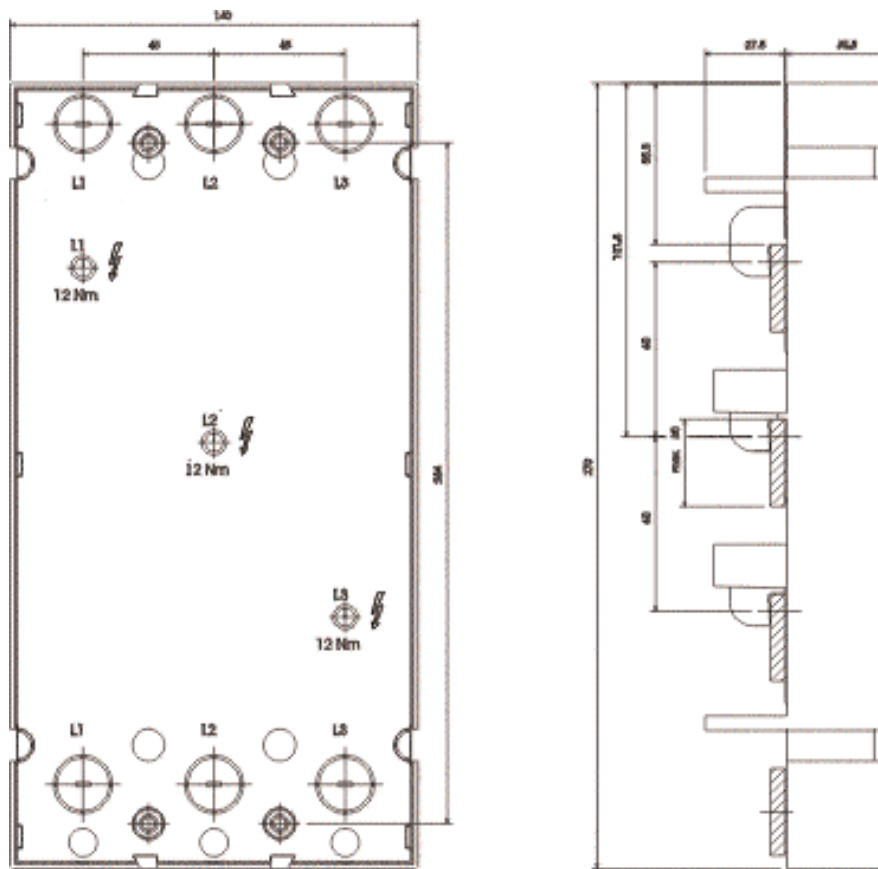

Dimensions

NZM3-XAD550



SASY 60i Busbar System

UL/CSA Approvals List

Article No.	Type Designation		
		USA ¹⁾	Canada
104554	NZM1-XAD160	✓	✓
104555	NZM2-XAD250	✓	✓
104556	NZM3-XAD550	✓	✓
101451	BBA0-25	✓	✓
101452	BBA0-32	✓	✓
101453	BBA0R-25	✓	✓
101454	BBA0R-32	✓	✓
101455	BBA0C-16	✓	✓
101456	BBA0RC-16	✓	✓
101457	BBA4-63	✓	✓
101458	BBA2-63	✓	✓
101459	BBA4L-63	✓	✓
101480	BBA2L-63	✓	✓
101481	BBA0-25/2TS	✓	✓
101482	BBA0/2TS-L	✓	✓
101483	BBA4/2TS-L	✓	✓
101484	BBA-XSM	✓	✓
107066	BBS-3/FL	✓	✓
107067	BBS-3/FL-NA	✓	✓
107068	ES-BBS-3/FL	✓	✓
107162	BBS-3/PR	✓	✓
107164	ES-BBS-3/PR	✓	✓
107165	BBS-1/PR	✓	✓
107166	CU-BAR-500/T	✓	✓
107167	CU-BAR-720/T	✓	✓
107172	BBC-BT-NA	✓	✓
107173	BBC-FL5	✓	✓
107174	BBC-FL10	✓	✓
107175	BBC-CU-BAR/PR	✓	✓
107178	BBC-RCOV1	✓	✓
107179	BBC-MRCOV1	✓	✓
107180	BBC-CS2-F	✓	✓
107181	BBC-CS2-T/B	✓	✓
107182	BBC-MCS2	✓	✓
107183	BBA-TP3/50	✓	✓
107184	BBA-TP3/120	✓	✓
107185	BBA-TP3/300	✓	✓
107186	BBA-TP3/CU-BAND	✓	✓
107187	AKU16/5	✓	✓
107188	AKU35/5	✓	✓
107189	AKU70/5	✓	✓
107190	AKU120/5	✓	✓
107191	AKU16/10	✓	✓
107192	AKU35/10	✓	✓
107193	AKU70/10	✓	✓
107194	AKU120/10	✓	✓
107195	AKS185	✓	✓
107196	AKS300	✓	✓
107197	AKS-CU-BAND	✓	✓
107198	AKP800	✓	✓
107199	AKP1000	✓	✓

¹⁾ Tested for feeder circuits according to UL-508A up to 600 V

UL-Approbation File No: E307559, E300273
 CSA-Approbation Report No: 236217, 232140
 UL File No. for CU-Band: E248096

SASY 60i Busbar System

Copper Weight

Article No.	Type Designation	Cu-Number ¹⁾
107166	CU-BAR-500/T	10.44
107167	CU-BAR-720/T	15.40
107183	BBA-TP3/50	0.03
107184	BBA-TP3/120	0.05
107198	AKP800	0.20
107199	AKP1000	0.23
107201	BBT-CU20-30X5/10-95	0.48
107202	BBT-CU20-30X5/10-150	0.76
107203	BBT-CU-BAR500/720-50	0.24
107204	BBT-CU-BAR500/720-150	0.79
104554	NZM1-XAD160	0.23
104555	NZM2-XAD250	0.32
104556	NZM3-XAD550	1.11
81167	CU-BAND3X9X0,8-BK	0.41
80960	CU-BAND3X9X0,8-BU	0.41
81006	CU-BAND3X9X0,8-GNYE	0.41
81414	CU-BAND6X9X0,8-BK	0.83
81344	CU-BAND6X9X0,8-BU	0.83
81367	CU-BAND6X9X0,8-GNYE	0.83
81515	CU-BAND9X9X0,8-BK	1.24
81436	CU-BAND9X9X0,8-BU	1.24
81485	CU-BAND9X9X0,8-GNYE	1.24
81310	CU-BAND6X16X0,8-BK	1.43
81222	CU-BAND6X16X0,8-BU	1.43
81275	CU-BAND6X16X0,8-GNYE	1.43
80739	CU-BAND10X16X0,8-BK	2.38
79736	CU-BAND10X16X0,8-BU	2.38
80698	CU-BAND10X16X0,8-GNYE	2.38
80923	CU-BAND11X21X1-BK	4.44
80769	CU-BAND11X21X1-BU	4.44
80836	CU-BAND11X21X1-GNYE	4.44
284690	LTS-100/C00/3-R	0.22
224550	GST00-160-40-60-AOU	0.23
107250	GST1-AO	1.08
107251	GST1-AU	1.12
107252	GST2-AO	1.61
107253	GST2-AU	1.63
107254	GST3-AO	2.42
107255	GST3-AU	2.42
284649	D02-S/63/3-RS	0.08
107964	D02-SO/63/3-R	0.04
101451	BBA0-25	0.03
101452	BBA0-32	0.05
101453	BBA0R-25	0.03
101454	BBA0R-32	0.05
101455	BBA0C-16	0.03
101456	BBA0RC-16	0.03
101457	BBA4-63	0.12
101458	BBA2-63	0.12
101459	BBA4L-63	0.12
101480	BBA2L-63	0.12
101481	BBA0-25/2TS	0.03

¹⁾ Extra charges

In the event of any significant increase in raw material prices (like of aluminium, copper, silver, plastic, steel), an extra charge for material might be invoiced where necessary. In case of exceeding the price limit of Euro 150.00/100kg according to the copper quotation (DEL-Notiz = Deutsche Elektrolyte Kupfer Notiz) and the aluminium quotation for processed metal and conducting aluminium, we will add an extra charge for material in euros, net, according to the quotation of the day we receive the order:

Copper:

DEL-Notiz – Euro 150.00

100 x Cu-Number

Aluminium:

Al-quotation – Euro 150.00

100 x Al-Number

Germany
Internet: www.moeller.net

Berlin
Moeller Electric GmbH
Moeller Haus Berlin
Ullsteinstraße 87
12109 Berlin
Tel. (030) 70 19 02-0
Fax (030) 70 19 02-39
E-Mail: moeller-berlin@moeller.net

Düsseldorf
Moeller Electric GmbH
Moeller Haus Düsseldorf
Im Taubental 32
41468 Neuss
Tel. (0 21 31) 3 17-0
Fax (0 21 31) 3 17-2 76
E-Mail: moeller-duesseldorf@moeller.net

Frankfurt
Moeller Electric GmbH
Moeller Haus Frankfurt
Berner Straße 111
60437 Frankfurt
Tel. (0 69) 5 00 89-0
Fax (0 69) 5 00 89-2 70
E-Mail: moeller-frankfurt@moeller.net

Hamburg
Moeller Electric GmbH
Moeller Haus Hamburg
Georgswerder Bogen 3
21109 Hamburg
Tel. (040) 7 50 19-0
Fax (040) 7 50 19-2 69
E-Mail: moeller-hamburg@moeller.net

München
Moeller Electric GmbH
Moeller Haus München
Wernher-von-Braun-Straße 5
85640 Putzbrunn
Tel. (089) 4 60 95-0
Fax (089) 4 60 95-2 67
E-Mail: moeller-muenchen@moeller.net

Stuttgart
Moeller Electric GmbH
Moeller Haus Stuttgart
Schelmenwasenstraße 32
70567 Stuttgart
Tel. (07 11) 6 87 89-0
Fax (07 11) 6 87 89-99
E-Mail: moeller-stuttgart@moeller.net

Moeller GmbH
Hein-Moeller-Str. 7-11
D-53115 Bonn

E-Mail: info@moeller.net
Internet: www.moeller.net

© 2007 by Moeller GmbH
Subject to alteration
FK4300-1167 GB (04/07)
Printed in Austria (04/07)
Graphic: Werbeweber, Schrems
DigiPics, Lithos: Jonas, Heidenreichstein
Druck: Rabl, Schrems
Article No.

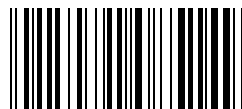

Xclever home

With Xclever home, Moeller offers the complete electrical installation from one source for a safe and easily controllable building. All Xclever home product groups stand out because of their high safety standards and simple and easy application.



Combines all functional and assembly safety advantages. From circuit-breakers and modular installation devices to over-voltage protection.



The complete distribution program for safe electrical installations from 63 to 2500 Amps. For houses, blocks of flats or functional buildings.



Covers all requirements of operation in buildings. The system opens new business possibilities for new and renovated buildings.



A clever, complete range that can be flexibly extended for the installation of future-orientated data networks.

MOELLER 

We keep power under control.